

A LEGACY BUILT ON POWER

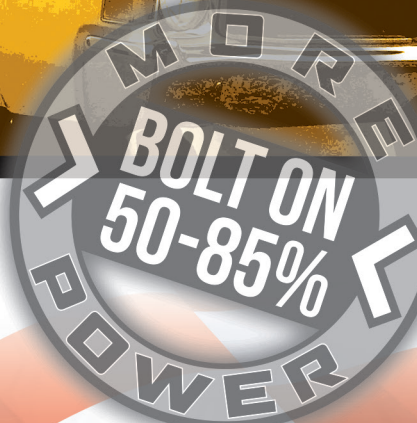

FULL LINE CATALOG

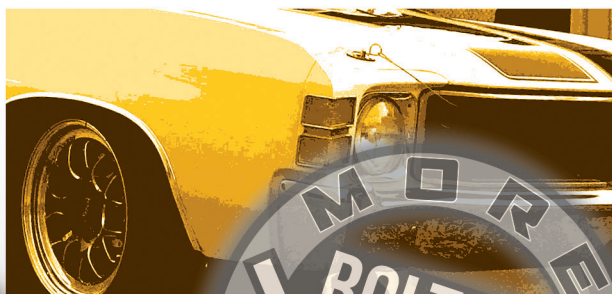

LEARN MORE AT PROCHARGER.COM



800+ HP!

THE WORLD'S MOST POWERFUL SUPERCHARGERS™

MUSTANG / COBRA / GT350 6	CRANKDRIVE™ / BELLMOUTH 23
COYOTE / GODZILLA SWAPS 11	GM TRUCK / SUV 24
CORVETTE 12	FORD TRUCK / SUV 26
CAMARO / FIREBIRD 14	DODGE TRUCK / RAM 28
CTS-V, G8, GTO AND CHEVY SS . . . 16	DURANGO SRT 29
LS AND LTI / LT4 SWAPS 17	JEEP 30
SB AND BB CHEVY 17	TOYOTA 31
DODGE HEMI / SRT 18	POWERSPORTS / SPORT COMPACT . . . 32
BLOW-OFF VALVES 21	V-TWIN 33
RACE BLOWERS 22	MARINE 33

CALL FOR LATEST MODEL YEARS

215+ HP Gain



With ProCharger® technology, reliably adding big horsepower to your engine is a lot easier than you may think. Intercooled ProCharger systems utilize exclusive features and proven technology to deliver reliable 40-85%+ emissions legal power gains with pump gas. Street systems are complete, and daily driveability is unchanged. Intercooled ProCharger systems provide the coolest engine intake charge air temperatures ever, and are so durable they feature the industry's best warranty coverage. ProCharger is also the undisputed leading manufacturer of competition superchargers, with hp gains of 100%–250% common in ProCharged racing applications. Street or strip, ProCharger technology is unmatched. Nothing else comes close!



33 CHAMPIONSHIPS IN THE PAST YEAR, MORE THAN ALL COMPETITORS COMBINED



WORLD'S FASTEST SUPERCHARGED C8!

PROCHARGER: THE ULTIMATE POWER ADDER®



ProCharger P-1X/D-1X

STREET/STRIP MODELS

- Patented design, no oil lines
- 3-year warranty available
- Emissions legal
- Helical Gearset option for reduced noise level
- 250–1075 hp



ProCharger F-4X

RACE MODELS

- Patented friction reduction drive
- 4.77:1–5.63:1 step-up ratio
- Unmatched power and durability
- 9", 9.75", 10.5", 12" and 13.5" volute diameters
- 500–4500+ hp

**RACE BLOWERS AND ACCESSORIES
PAGES 22-23**

**Camaro SS
Bolt On 170+ HP**

**RAM 5.7L
140+ HP GAIN**



SUPERIOR TECHNOLOGY

Thanks to relentless innovation, ProCharger technology is generations ahead of the competition. Our exclusive, patented, self-contained, and gear-driven superchargers eliminate tapping into your oil pan, run cooler and produce more power than our competitor's products. With their rugged design, these ProChargers were the first self-contained superchargers durable enough to be backed with a 3-year warranty and powerful enough to harness the benefits of intercooling. Standard superchargers also feature an internal step-up ratio of 4.10:1 for improved belt tracking and traction, and maximum low-rpm boost and power. Combined with ProCharger's superior intercooler designs, this technology creates the ultimate supercharger systems for your street or strip vehicle, with far more power than competing supercharger systems.

- Superior technology produces the undisputed largest power gains with pump gas, and up to twice the maximum horsepower of others
- Largest 50 state emissions-legal power gains
- Patented self-contained superchargers for car, truck, motorcycle and marine applications
- Simple underhood installation
- Industry-best supercharger warranty coverage
- The most complete lineup of superchargers and kits, with both intercooled and non-intercooled systems for 400–4500+ horsepower
- ProCharger has more experience with today's fuel injected and carbureted engines than any other supercharger manufacturer
- Industry leading service and support

THE INDUSTRY STANDARD

With 30 years of innovation and experience, ProCharger is the industry leader for aftermarket supercharger systems. The company has built the industry's broadest product line, with systems that produce the most street legal power, and as well as the most powerful race supercharger kits. This tremendous progress has largely been the result of listening to customers and dealers, exploring innovative design options, and investing in technology.

The success of this approach is evidenced not only by the many accomplishments of ProCharger's customers, but also by the 34 patents awarded to the company, with many more pending. The company's unmatched innovation and accomplishments have also generated much praise and recognition in the automotive press. However, ProCharger's staff is never satisfied, and will keep working hard to ensure that ProCharger products are the best available.



INDUSTRY'S BEST WARRANTY

Intercooled ProCharger supercharger systems are absolutely the most powerful and reliable centrifugal supercharger systems available for your vehicle. Nothing else even comes close. We stand firmly behind our systems with the industry's best warranty, which is possible due to the quality and design of ProCharger systems. See procharger.com/terms-conditions/ for details on ProCharger's standard warranty, optional extended supercharger warranty, and optional powertrain warranty.

50-STATE LEGAL EMISSIONS COMPLIANT

ProCharger is the leader in 50-state legal aftermarket boost, offering the most emissions legal supercharger systems in the industry. ProCharger systems with CARB Executive Orders (EO's) are available for a growing number of automotive, truck and SUV applications, and the ProCharger engineering team works hard to stay current on the latest model years and new vehicle applications. For more information on emissions certifications, scan the QR code, give us or your local dealer a call, or visit ww2.arb.ca.gov.

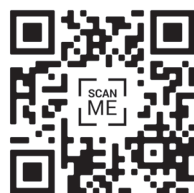

INTERCOOLING ADVANTAGE

Because of its many benefits, intercooling has become the standard for high performance forced induction systems. For automotive street or strip use, air-to-air technology is the dominant intercooler design for both the aftermarket and OEM's, especially with centrifugal compressors (superchargers and turbochargers). Air-to-air intercooling is a natural fit because it allows installation at the front of the car in a fresh air stream, rather than above the hot engine or exhaust. It also avoids having to relocate the battery to the trunk, as well as the risk of engine damage due to a pump or line problem. The largest advantage of air-to-air intercooling however, is its superior performance and reliability.

"Street cars will benefit much more from an air-to-air intercooler. This is because the coolest air charge [from an air-to-water intercooler] is available only with a fresh charge of ice and water. Ice melts quickly when circulated through an intercooler, so its useful life is measured only in minutes."
—Muscle Mustangs and Fast Fords

"When space permits an adequately sized air-to-air intercooler to be fitted and given access to decent airflow, it will always prove superior. The only excuse for a liquid-based intercooler is when severe space restrictions exist [including positive displacement superchargers, due to mounting location] or ... where an iced coolant can be used."
—SuperCharged, Corky Bell

THE MOST POWER PER POUND OF BOOST

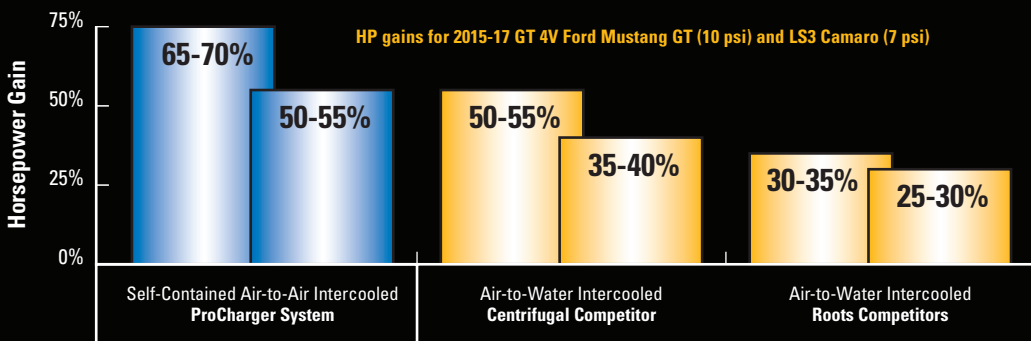
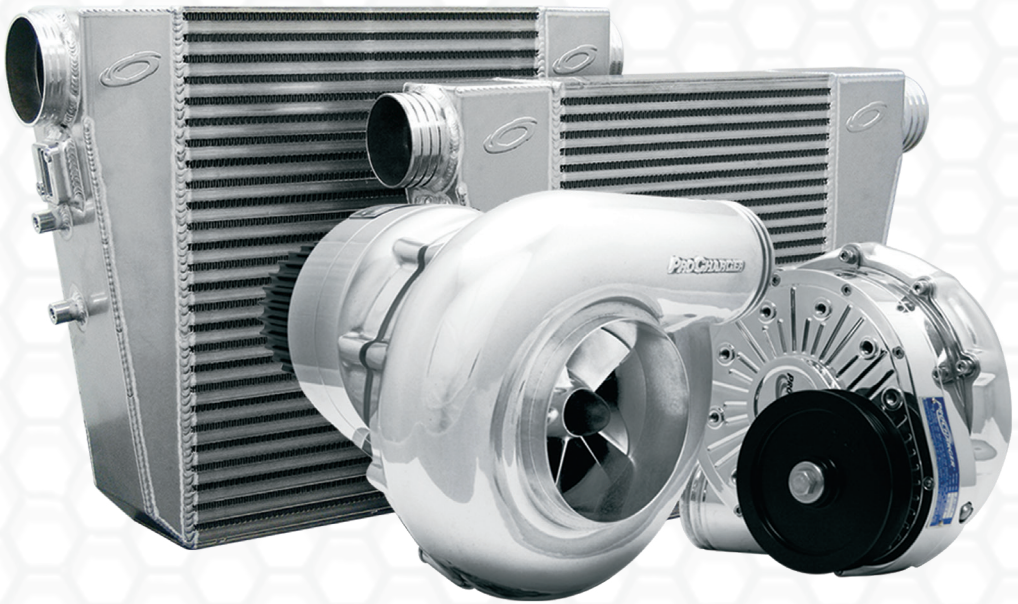

ProCharger's industry-leading superchargers and intercooling technology typically produce not only far greater HP gains than any other supercharger manufacturer, but also more power per pound of boost



MUSTANG

2024+ MUSTANG GT
800+ HP



2024+ Mustang GT System with P-1X

NEW! 2024-25 MUSTANG (5.0 4V) GT / DARK HORSE

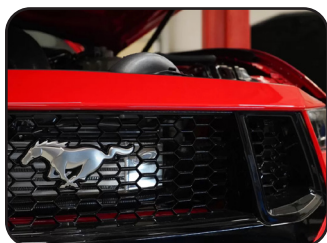

Year/Model	Part #	HP Gain	Description
2024-25 GT	1EB214-SCI	325 HP	12 psi with P-1X
2024-25 GT	1EB212-SCI	call	Stage II with P-1X
2024-25 GT	1EB200-P1X	specify	Race Kit with P-1X
2024-25 GT	1EB200-94	specify	Race Kit with F-1A-94

2018-23 MUSTANG (5.0 4V) GT / BULLITT / CALI SPECIAL / MACH 1



Year/Model	Part #	HP Gain	Description
2018-23 GT	1FW611-SCI	65-70%+	10 psi with P-1SC-1
2018-23 GT	1FW601-SCI	specify	Tuner Kit with P-1SC-1
2018-23 GT	1FW614-SCI	65-70%+	10 psi with P-1SC-1/P-1X
2018-23 GT	1FW604-SCI	specify	Tuner Kit with P-1SC-1/P-1X
2018-23 GT	1FW613-SCI	75-80%+	12 psi Stage II with P-1SC-1
2018-23 GT	1FW603-SCI	specify	Stage II Tuner Kit with P-1SC-1/D-1SC
2018-23 GT	1FW612-SCI	75-80%+	12 psi Stage II with P-1SC-1/P-1X
2018-23 GT	1FW602-SCI	specify	Stage II Tuner Kit with P-1SC-1/D-1SC

Refer to ProCharger.com/streetlegal for the latest emissions certification details.

2015-17 MUSTANG (5.0 4V)



Year/Model	Part #	HP Gain	Description
2015-17 GT	1FW411-SCI	55-60%+	8 psi with P-1SC-1
2015-17 GT	1FW401-SCI	specify	Tuner Kit with P-1SC-1
2015-17 GT	1FW214-SCI	55-60%+	8 psi with P-1SC-1/P-1X
2015-17 GT	1FW204-SCI	specify	Tuner Kit with P-1SC-1/D-1SC
2015-17 GT	1FW412-SCI	60-65%+	9 psi Stage II with P-1SC-1
2015-17 GT	1FW402-SCI	specify	Stage II Tuner Kit with P-1SC-1/D-1SC
2015-17 GT	1FW212-SCI	65-70%+	10 psi Stage II with P-1SC-1/P-1X
2015-17 GT	1FW202-SCI	specify	Stage II Tuner Kit with P-1SC-1/D-1SC

50 State Legal E.O. System
 Uses Factory Air Box

Blue = intercooled products
 Black = non-intercooled products

6.05 @ 231 mph, ProCharger F-3R-136



#PROCHARGER

2015-20 SHELBY GT350/R (5.2 4V)

Year/Model	Part #	HP Gain	Description
2015-20	1FW312-SCI	175+ HP	6 psi with P-1SC-1/P-1X
2015-20	1FW302-SCI	specify	Tuner Kit with P-1SC-1/D-1SC
2015-20	1FW314-SCI	350+ HP	9 psi Stage II with P-1SC-1/P-1X
2015-20	1FW304-SCI	specify	Stage II Tuner Kit with P-1SC-1/D-1SC



2011-14 MUSTANG (5.0 4V)

Year/Model	Part #	HP Gain	Description
2011-14 GT	1FR211-SCI 	50%+	7.5 psi with P-1SC-1 (shared drive) [FA]
2011-14 GT	1FR201-SCI	specify	Tuner Kit with P-1SC-1 (shared drive) [FA]
2011-14 GT	1FR214-SCI	50%+	7.5 psi with P-1SC-1/P-1X
2011-14 GT	1FR204-SCI	specify	Tuner Kit with P-1SC-1/P-1X
2011-14 GT	1FR212-SCI	55%+	8 psi Stage II with P-1SC-1/P-1X
2011-14 GT	1FR202-SCI	specify	Stage II Tuner Kit with P-1SC-1/D-1SC
2011-14 GT	1FR200-F1 / -F1R	specify	Cog Race Kit with F-1D, F-1 or F-1A / F-1A-94, F-1C or F-1R



2012-13 BOSS 302 MUSTANG

Year/Model	Part #	HP Gain	Description
2012-13	1FR311-SCI 	call	8.5 psi with P-1SC-1 (shared drive) [FA]
2012-13	1FR301-SCI	specify	Tuner Kit with P-1SC-1 (shared drive) [FA]
2012-13	1FR312-SCI	50%+	8.5 psi Stage II with P-1SC-1/P-1X
2012-13	1FR302-SCI	specify	Stage II Tuner Kit with P-1SC-1/D-1SC
2012-13	1FR300-F1 / -F1R	specify	Cog Race Kit with F-1D, F-1 or F-1A / F-1A-94, F-1C or F-1R



2011-17 MUSTANG V6 (3.7)

Year/Model	Part #	HP Gain	Description
2015-17	1FT412-SCI	50-55%	8 psi with P-1SC-1
2015-17	1FT402-SCI	specify	Tuner Kit with P-1SC-1/D-1SC
2011-14	1FT212-SCI	50-60%	8 psi with P-1SC-1
2011-14	1FT202-SCI	specify	Tuner Kit with P-1SC-1/D-1SC





MUSTANG



2005-10 MUSTANG (4.6 3V)



Year/Model	Part #	HP Gain	Description
2005-10 GT	1FP311-SCI	70-75%	10 psi with P-1SC-1 (shared drive)
2005-10 GT	1FP301-SCI	specify	Tuner Kit with P-1SC-1 (shared drive)
2005-10 GT	1FP214-SCI	70-75%	10 psi with P-1SC-1/P-1X
2005-10 GT	1FP204-SCI	specify	Tuner Kit with P-1SC-1/P-1X
2005-09 GT	1FP211-SCI	70-75%	10 psi Stage II with P-1SC-1/P-1X
2005-09 GT	1FP202-SCI	specify	Stage II Tuner Kit with P-1SC-1/D-1SC
2005-09 GT	1FP213-F1	specify	Serpentine Race Kit with F-1A

2005-10 MUSTANG V6 (4.0)



Year/Model	Part #	HP Gain	Description
2005-10	1FQ211-SCI	45-50%	6 psi with P-1SC
2005-10	1FQ212-SCI	55-60%	8 psi Stage II with P-1SC
2005-10	1FQ202-SCI	specify	Tuner Kit with P-1SC/D-1SC

2003-04 MACH 1 (4.6 4V)



Year/Model	Part #	HP Gain	Description
2003-04 Mach 1	1FL212-SCI	60-65%	8 psi Stage II with P-1SC
2003-04 Mach 1	1FL202-SCI	specify	Stage II Tuner Kit with P-1SC-1/D-1SC

2003-04 COBRA (4.6 4V)



Year/Model	Part #	HP Gain	Description
2003-04	1FM202-SC	550+	HO Tuner Kit with P-1SC-2/D-1SC
2003-04	1FM203-SC	620+	Stage II Tuner Kit with F-1D, F-1 or F-1A
2003-04	1FM204-SC-C	750+	Cog Race Kit with F-1D, F-1 or F-1A

50 State Legal E.O. System
 Uses Factory Air Box

Blue = intercooled products
 Black = non-intercooled products

1999-04 MUSTANG (4.6 2V) GT / BULLITT

Year/Model	Part #	HP Gain	Description
1999-04 GT	1FE212-SCI 	55-60%	8 psi with P-1SC
1999-04 GT	1FE202-SCI	specify	Tuner Kit with P-1SC
1999-04 GT	1FE211-SCI	60-65%	8 psi Stage II with P-1SC-1/D-1SC
1999-04 GT	1FE201-SCI	specify	Stage II Tuner Kit with P-1SC-1/D-1SC
2001 Bullitt	add "-B" to part #	see above	see above



1999-01 COBRA (4.6 4V)

Year/Model	Part #	HP Gain	Description
1999-01 Cobra	1FF211-SCI	45-50%	6 psi with P-1SC
1999-01 Cobra	1FF201-SCI	specify	Tuner Kit with P-1SC
1999-01 Cobra	1FF212-SCI	60-65%	8 psi Stage II with P-1SC
1999-01 Cobra	1FF202-SCI	specify	Stage II Tuner Kit with P-1SC



1996-98 COBRA (4.6 4V)

Year/Model	Part #	HP Gain	Description
1996-98 Cobra	1FC211-10I 	45-50%	6 psi with P-1SC
1996-98 Cobra	1FC201-SCI	specify	Tuner Kit with P-1SC
1996-98 Cobra	1FC212-SCI	60-65%	8 psi Stage II with P-1SC
1996-98 Cobra	1FC202-SCI	specify	Stage II Tuner Kit with P-1SC



1996-98 RACE KITS (4.6 4V)

Year/Model	Part #	HP Gain	Description
1996-98	1FX205-F1A	specify	Serpentine Race Kit with F-1D, F-1 or F-1A
1996-98	1FX244-F1C	specify	Cog Race Kit with F-1C or F-1R



1996-98 MUSTANG (4.6 2V)

Year/Model	Part #	HP Gain	Description
1996-98 GT	1FD211-10I 	55-70%	8-10 psi with P-1SC
1996-98 GT	1FD201-SCI	specify	Tuner Kit with P-1SC
1996-98 GT	1FD212-SCI	60-80%	8-12 psi Stage II with P-1SC
1996-98 GT	1FD202-SCI	specify	Stage II Tuner Kit with P-1SC



NOTES: D-1SC and D-1X models are available as an upgrade for most Tuner Kits



1994-95 MUSTANG/COBRA (5.0)

Year/Model	Part #	HP Gain	Description
1994-95	1FB100-09I/11I/14I	60-85%	9-14 psi with P-1SC
1994-95	1FB202-SCI	specify	Tuner Kit with P-1SC
1994-95	1FB324-D1SC	85%+	15-22 psi Stage II with D-1SC
1994-95	1FB012-SCI	specify	High Output Kit with P-1SC



1994-04 MUSTANG V6 (3.8/3.9)

Year/Model	Part #	HP Gain	Description
1999-03	1F1202-SCI	60-80%	9-11 psi Stage II with P-1SC
1999-04	1F1200-SCI	specify	Tuner Kit with P-1SC
1994-98	1FJ212-SCI	75-80%	11 psi with P-1SC
1994-98	1FJ202-SCI	specify	Tuner Kit with P-1SC



1986-93 MUSTANG/COBRA (5.0)

Year/Model	Part #	HP Gain	Description
1986-93	1FA100-09I	60-85%	9 psi with P-1SC (8 rib)
1986-93	1FA100-11I	60-85%	11 psi with P-1SC (8 rib)
1986-93	1FA100-14I	60-85%	14 psi with P-1SC (8 rib)
1986-93	1FA202-SCI	specify	Tuner Kit with P-1SC (8 rib)
1986-93	1FA324-D1SC-8R	85%+	15-25 psi Stage II with D-1SC (8 rib)
1986-93	1FA012-SC	specify	High Output Kit with P-1SC

Twin-Highflow Intercooler System Available for Modified and Lowered 5.0's



1964 1/2-73 EARLY FORD (289/302/351)

Year/Model	Part #	HP Gain	Description
1964.5-73	1FX400-P1SC	specify	High Output with P-1SC (8-rib)
1964.5-73	1FX400-P1SC-I	specify	High Output with P-1SC (8-rib)

* Call for '69-'73 Mustang, and '66-'73 Fairlane, Maverick, Comet, Falcon, Torino.

- Blue = intercooled products
- Black = non-intercooled products

COYOTE SWAP (5.0 4V)

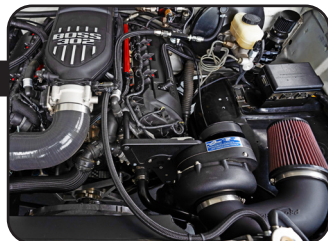

Year/Model	Part #	HP Gain	Description
specify	1FA400-P1SC1-I	specify	High Output Tuner Kit with P-1SC-1/P-1X
specify	1FA400-P1SC1	specify	High Output Tuner Kit with P-1SC-1/P-1X
specify	1FA400-F1-I	specify	Cog Kit with F-1A, F-1A-94 or F-1R
specify	1FA400-F1	specify	Cog Kit with F-1A, F-1A-94 or F-1R
specify	1FA500-P1SC1-I	specify	Reverse rotation Kit with P-1SC-1/P-1X
specify	1FA500-P1SC1	specify	Reverse rotation Kit with P-1SC-1/P-1X
specify	1FA500-F1-I	specify	Reverse rotation Kit with F-1A, F-1A-94 or F-1R
specify	1FA500-F1	specify	Reverse rotation Kit with F-1A, F-1A-94 or F-1R
specify	1FA700-P1SC1-I	specify	High Output Tuner Kit with P-1SC-1
specify	1FA700-P1SC	specify	High Output Tuner Kit with P-1SC-1

GODZILLA SWAP (7.3)



Year/Model	Part #	HP Gain	Description
specify	1FA600-P1SC1-I	specify	Stage II Tuner Kit with P-1SC-1, P-1X, D-1SC, D-1X
specify	1FA600-P1SC1	specify	Stage II Tuner Kit with P-1SC-1, P-1X, D-1SC, D-1X
specify	1FA600-F1-I	specify	Stage II Tuner Kit with F-1A, F-1A-94, F-1R, F-1X
specify	1FA600-F1	specify	Stage II Tuner Kit with F-1A, F-1A-94, F-1R, F-1X

SBF SERPENTINE

ACCESSORY DRIVE KITS **NEW!**

Year/Model	Part #	HP Gain	Description
specify	1EX300	specify	Serp Acc Drive with crank pulley + alternator + water pump (P/S and A/C optional)
specify	1EX400	specify	Serp Acc Drive with P-1SC-1, P-1X, D-1SC, D-1X, F-1A, F-1A-94, F-1X, F-2

SERPENTINE RACE KITS (5.0)



Year/Model	Part #	HP Gain	Description
1985-93	1FX012-P1SC	specify	High Output with P-1SC (8 rib)
1985-93	1FX212-P1SC-I	specify	High Output Intercooled with P-1SC (8 rib)
1985-93	1FX013-P1SC2	specify	High Output Kit with P-1SC-2 (8 rib)
1985-93	1FX022-D1SC	specify	High Output with D-1SC (12 rib)
1985-93	1FX222-D1SC-I	specify	High Output Intercooled with D-1SC (12 rib)
1985-93	1FX024-F1A94 / F1C / F1R	specify	8 rib Race Kit with F-1A-94, F-1C or F-1R (EFI Renegade)
1985-93	1FX124-F-1D / F1 / F1A	specify	High Output with F-1D, F-1, or F-1A (12 rib)
1985-93	1FX324-F-1D-I / F1-I / F1A-I	specify	High Output Intercooled with F-1D, F-1, or F-1A (12 rib)
1985-93	1FX022-F1A94 / F1C / F1R	specify	High Output with F-1A-94, F-1C or F-1R (12 rib)
1985-93	1FX124-F1A94-I / F1C-I / F1R-I	specify	High Output Intercooled with F-1A-94, F-1C or F-1R (12 rib)

COG RACE KITS (5.0)

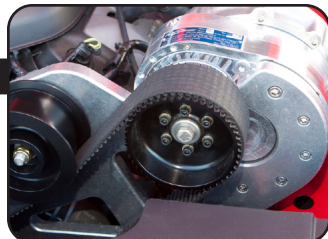

Year/Model	Part #	HP Gain	Description
1985-93	1FX224-F-1D / F1 / F1A	specify	Cog Race Kit with F-1D, F-1, F-1A
1985-93	1FX234-F-1D-I / F1-I / F1A-I	specify	Cog Race Kit Intercooled with F-1D, F-1, or F-1A
1985-93	1FX224-F1C / F1R	specify	Cog Race Kit with F-1C, F-1R
1985-93	1FX234-F1C-I / F1R-I	specify	Cog Race Kit Intercooled with F-1C or F-1R
1985-93	1FX224-F1X	specify	Cog Race Kit with F-1X
1985-93	1FX234-F1X-I	specify	Cog Race Kit Intercooled with F-1X
1985-93	1FX224-F2	specify	Cog Race Kit with F-2

2014 Mustang GT, 7.830 @ 177mph, P-1X

10.87 @ 131 mph, 7.5 psi, stock 5.0 4V, headers, pump gas





885+ HP
C8 E-RAY



NEW!

CORVETTE C8 STINGRAY, E-RAY (LT2)

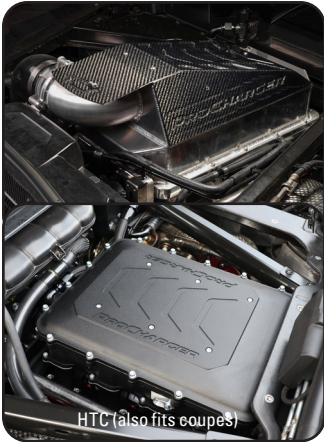

HTC (also fits coupes)

Year/Model Part# HP Gain Description

LOW PROFILE (COUPE AND HTC)

2020-24 1KC512-SCI 170+ 5 psi with P-1SC-1
2020-24 1KC612-SCI 230+ Stage II 7.5 psi with P-1SC-1

STANDARD PROFILE (COUPE)

2020-24 1KC312-SCI 170+ 5 psi with P-1SC-1
2020-24 1KC412-SCI 230+ Stage II 7.5 psi with P-1SC-1
2020-24 1KC402-SCI specify Tuner Kit with P-1SC-1



CORVETTE C7 (LT1)

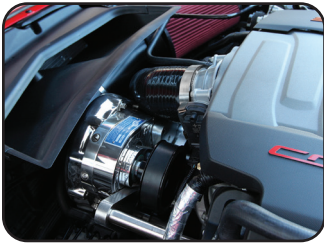

Year/Model Part# HP Gain Description

2014-19 1GU212-SCI 50 40%+ 7 psi with P-1SC-1/P-1X
2014-19 1GU202-SCI specify Tuner Kit with P-1SC-1/D-1SC
2014-19 1GU402-F1 specify Competition Race Tuner Kit w/ F-1D, F-1, F-1A
2014-19 1GU402-F1R specify Competition Race Tuner Kit w/ F-1A-94, F-1C, F-1R
2014-19 1GU502-F1 specify Pro Race Tuner Kit w/ F-1D, F-1, F-1A
2014-19 1GU502-F1R specify Pro Race Tuner Kit w/ F-1A-94, F-1C, F-1R

CORVETTE C7 Z06 (LT4)



Year/Model Part# HP Gain Description

2015-19 1GU204-SCI specify Tuner Kit with D-1SC
2015-19 1GU204-SCI-F1 specify Race Tuner Kit with F-1D, F-1 or F-1A
2015-19 1GU204-SCI-F1R specify Race Tuner Kit with F-1A-94, F-1C or F-1R
2015-19 1GU300-F1 specify Competition Race Tuner Kit w/ F-1D, F-1, F-1A
2015-19 1GU300-F1R specify Competition Race Tuner Kit w/ F-1A-94, F-1C F-1R
2015-19 1GU500-F1 specify Pro Race Tuner Kit w/ F-1D, F-1, F-1A
2015-19 1GU500-F1R specify Pro Race Tuner Kit w/ F-1A-94, F-1C, F-1R

50 State Legal E.O. System

NOTES: D-1SC and D-1X models are available as an upgrade for most Tuner Kits. Optional P-1X Head Unit, Helical Gears and Polished or Black finish upgrades are available for both Systems and Tuner Kits.

2017 C7 Z06 - ProCharger F-1X - 7.61 @ 165 mph 1/4 mile

ProCharger F-3X-140 - 3500+ HP



CORVETTE C6 (LS3/LS7/LS2)

Year/Model	Part #	HP Gain	Description
2008-13 (LS3)	1GQ212-SCI	45-50%+ specify	7 psi with P-1SC-1/P-1X Tuner Kit with P-1SC-1/P-1X
2008-13 (LS3)	1GQ202-SCI	45-50%+ specify	7 psi Stage II with P-1SC-1/P-1X
2008-13 (LS3)	1GQ314-SCI	45-50%+ specify	Stage II Tuner Kit with P-1SC-1/P-1X
2008-13 (LS3)	1GQ304-SCI	45-50%+ specify	Race kit with F-1D, F-1, F-1A, F-1C or F-1R
2008-13 (LS3)	1GQ402-SCI	45-50%+ specify	Race kit with F-1D, F-1, F-1A, F-1C or F-1R
2006-13 (LS7)	1GP214-SCI	40%+ specify	4.5 psi with P-1SC-1/P-1X Tuner Kit with P-1SC-1/P-1X
2006-13 (LS7)	1GP204-SCI	40%+ specify	4.5 psi Stage II with P-1SC-1/P-1X
2006-13 (LS7)	1GP314-SCI	40%+ specify	Stage II Tuner Kit with P-1SC-1/P-1X
2006-13 (LS7)	1GP304-SCI	40%+ specify	Race Kit with F-1D, F-1 or F-1A
2006-13 (LS7)	1GP404-SCI	40%+ specify	Race Kit with F-1A-94, F-1C or F-1R
2006-13 (LS7)	1GP404-F-1C-SCI	40%+ specify	Race Kit with F-1A-94, F-1C or F-1R
2005-07 (LS2)	1GP202-SCI	50%+ specify	6 psi with P-1SC-1/P-1X Tuner Kit with P-1SC-1/P-1X
2005-07 (LS2)	1GP212-SCI	50%+ specify	6 psi Stage II with P-1SC-1/P-1X
2005-07 (LS2)	1GP315-SCI	50%+ specify	Stage II Tuner Kit with P-1SC-1/P-1X
2005-07 (LS2)	1GP305-SCI	50%+ specify	Race Kit with F-1D, F-1 or F-1A
2005-07 (LS2)	1GP402-SCI	50%+ specify	Race Kit with F-1D, F-1 or F-1A
2005-07 (LS2)	1GP402-F-1C or -F-1R-SCI	50%+ specify	Race Kit with F-1A-94, F-1C or F-1R



Refer to ProCharger.com/streetlegal for the latest emissions certification details.



CORVETTE C5 (LS1)

Year/Model	Part #	HP Gain	Description
1999-04	1GK213-SCI	55%+ specify	7 psi with P-1SC-1 Tuner Kit with P-1SC-1
1997-04	1GK203-SCI	55%+ specify	7 psi Stage II with P-1SC-1
1999-04	1GK414-SCI	55%+ specify	Stage II Tuner Kit with P-1SC-1
1997-04	1GK404-SCI	55%+ specify	Stage II Tuner Kit with P-1SC-1



CORVETTE C5 Z06 (LS6)

Year/Model	Part #	HP Gain	Description
2001-04	1GK216-SCI	50%+ specify	6 psi with P-1SC-1 Tuner Kit with P-1SC-1
2001-04	1GK206-SCI	50%+ specify	6 psi Stage II with P-1SC-1
2001-04	1GK219-SCI	50%+ specify	Stage II Tuner Kit with P-1SC-1
2001-04	1GK209-SCI	50%+ specify	Stage II Tuner Kit with P-1SC-1

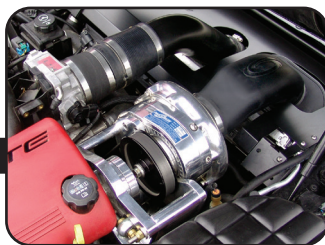

CORVETTE C4 (LT1/LT4/L98)

Year/Model	Part #	HP Gain	Description
1992-95 (LT1)	1GF211-SCI	55-60% specify	8 psi with P-1SC-1 Tuner Kit with P-1SC
1992-95 (LT1)	1GF201-SCI	55-60% specify	8 psi Stage II with P-1SC-1
1996 (LT4)	1GF212-SCI	45-50% specify	6 psi with P-1SC Tuner Kit with P-1SC
1996 (LT4)	1GF202-SCI	45-50% specify	6 psi Stage II with P-1SC-1
1985-91 (L98)	1GB212-08I	55-75% specify	8 psi with P600B Tuner Kit with P600B
1985-91 (L98)	1GB211-06S	55-75% specify	8 psi Stage II with P600B
1985-91 (L98)	1GB212-D1	75%+ specify	10+ psi with D-1 Tuner Kit with D-1
1985-91 (L98)	1GB211-D1	75%+ specify	10+ psi Stage II with D-1

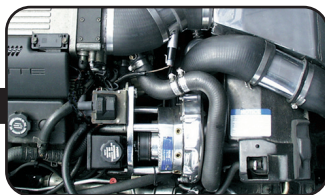

Blue = intercooled products
 Black = non-intercooled products

NOTES: D-1SC and D-1X models are available as an upgrade for most Tuner Kits

2007 C6 Z06
 ProCharger F-1A-94
 4.70 @ 150 mph
 1/8th mile





BOLT ON 150-200+ HP



CAMARO SS (LT1)

Year/Model	Part #	HP Gain	Description
2016-24	1GY211-SCI	150+	7 psi with P-1SC-1
2016-24	1GY201-SCI	specify	Tuner Kit with P-1SC-1
2016-24	1GY212-SCI	150+	7 psi with P-1SC-1/P-1X
2016-24	1GY202-SCI	specify	Tuner Kit with P-1SC-1/P-1X
2016-24	1GY312-SCI	170+	7 psi with P-1SC-1/P-1X
2016-24	1GY302-SCI	specify	Tuner Kit with P-1SC-1/P-1X
2016-24	1GY402-F1	specify	Competition Race Tuner Kit w/ F-1D, F-1 or F-1A
2016-24	1GY402-F1R	specify	Competition Race Tuner Kit w/ F-1A-94, F-1C or F-1

Refer to ProCharger.com/streetlegal for the latest emissions certification details.



CAMARO ZL1 (LT4)

Year/Model	Part #	HP Gain	Description
2017-21	1GY204-SCI	specify	Stage II Tuner Kit with D-1SC
2017-21	1GY404-F1	specify	Race Tuner Kit with F-1D, F-1, or F-1A
2017-21	1GY404-F1R	specify	Race Tuner Kit with F-1A-94, F-1C or F-1R
2017-21	1GY300-F1	specify	Competition Race Tuner Kit w/ F-1D, F-1, or F-1A
2017-21	1GY300-F1R	specify	Competition Race Tuner Kit w/ F-1A-94, F-1C, or F-1R



CAMARO V6

Year/Model	Part #	HP Gain	Description
2016-21	1GZ212-SCI	specify	7psi with P-1SC-1
2016-21	1GZ202-SCI	specify	Tuner Kit with P-1SC-1

No Prep Kings Champion
F-4X-140-1, 3500+ HP





50 State Legal E.O. System
 Uses Factory Air Box

NOTES: D-1SC and D-1X models are available as an upgrade for most Tuner Kits. Optional P-1X Head Unit, Helical Gears and Polished or Black finish upgrades are available for both Systems and Tuner Kits.



CAMARO SS (LS3/L99)

Year/Model	Part #	HP Gain	Description
2010-15	1GT214-SCI 	50%	7 psi with P-1SC-1 (supplied airbox)
2010-15	1GT212-SCI	50%	7 psi with P-1SC-1/P-1X
2010-15	1GT202-SCI	specify	Tuner Kit with P-1SC-1/D-1SC
2010-15	1GT314-SCI 	55%+	7.5 psi Stage II with P-1SC-1 (supplied airbox)
2010-15	1GT312-SCI	55%+	7.5 psi Stage II with P-1SC-1/P-1X
2010-15	1GT302-SCI	specify	Stage II Tuner Kit with P-1SC-1/D-1SC
2010-15	1GT200-F-1	specify	Intercooled Cog Race Kit with F-1D, F-1 or F-1A
2010-15	1GT200-F1	specify	Cog Race Kit with F-1D, F-1 or F-1A

(F-1C, F-1A-94, F-1R and F-1X upgrades available for Tuner Kits)



Z/28 CAMARO (LS7)

Year/Model	Part #	HP Gain	Description
2014-15	1GT414-SCI	120+	6.5 psi Stage II with P-1SC-1/P-1X
2014-15	1GT404-SCI	specify	Stage II Tuner Kit with P-1SC-1/P-1X

(F-1D, F-1, F-1A, F-1C, F-1A-94 and F-1R upgrades available, Tuner Kits only)



CAMARO/FIREBIRD (LS1)

Year/Model	Part #	HP Gain	Description
1999-02	1GJ214-SCI 	40-55%	5-7 psi with P-1SC-1/P-1X
1998-02	1GJ213-SCI	specify	Tuner Kit with P-1SC-1/P-1X
1998-02	1GJ204-SCI	specify	Race Kit with D-1SC

(F-1D, F-1, F-1A and F-1A-94 upgrades available, Tuner Kits only)



Optional polished plenum

CAMARO/FIREBIRD (LT1)

Year/Model	Part #	HP Gain	Description
1993-97	1GA211-071 / 091 	55-60%	7-9 psi with P-1SC
1993-97	1GA201-SCI	specify	Tuner Kit with P-1SC
1993-97	1GA212-D1SC	specify	Serpentine Race Kit w/ D-1SC (12 rib)

(F-1D, F-1, F-1A and 10 Rib upgrades available for Serpentine Race Kit)

Refer to ProCharger.com/streetlegal for the latest emissions certification details.



CAMARO/FIREBIRD TPI (L98)

Year/Model	Part #	HP Gain	Description
1987**-92	1GC211-091 	65%+	9 psi with P-1SC
1987**-92	1GC201-SCI	specify	Tuner Kit with P-1SC
1987**-92	1GC201-D1SC	specify	Stage II Tuner with D-1SC

**1987 model years require Serpentine Accessory Belt Drive System, GM Part # 12497698
Refer to ProCharger.com/streetlegal for the latest emissions certification details.



 Blue = intercooled products
 Black = non-intercooled products

NOTES: D-1SC and D-1X models are available as an upgrade for most Tuner Kits



CADILLAC CTS-V (LT4)

Year/Model	Part #	HP Gain	Description
2016-19	1GY704-SCI	specify	Stage II Tuner Kit with D-1SC/D-1X/F-1A-94



PONTIAC GTO (LS1/LS2)

Year/Model	Part #	HP Gain	Description
2005-06 (LS2)	1GN312-SCI	50%	7 psi with P-1SC-1/P-1X
2005-06 (LS2)	1GN302-SCI	specify	Tuner Kit with P-1SC-1/D-1SC
2005-06 (LS2)	1GN313-F1A	specify	Serpentine Race Kit with F-1D, F-1 or F-1A
2004 (LS1)	1GN212-SCI 	50%	7 psi with P-1SC-1/P-1X
2004 (LS1)	1GN202-SCI	specify	Tuner Kit with P-1SC-1/D-1SC
2004 (LS1)	1GN213-F1A	specify	Serpentine Race Kit with F-1D, F-1 or F-1A



PONTIAC G8 GT (L99)

Year/Model	Part #	HP Gain	Description
2008-09	1GS212-SCI	50-55%	8 psi with P-1SC-1
2008-09	1GS202-SCI	specify	Tuner Kit with P-1SC-1/D-1SC



CHEVROLET SS (LS3)

Year/Model	Part #	HP Gain	Description
2014-17	1GW212-SCI	50%	8 psi with P-1SC-1/P-1X
2014-17	1GW202-SCI	specify	Tuner Kit with P-1SC-1/D-1SC

NOTES: D-1SC and D-1X models are available as an upgrade for most Tuner Kits. Optional P-1X Head Unit, Helical Gears and Polished or Black finish upgrades are available for both Systems and Tuner Kits.

 50 State Legal E.O. System
 Uses Factory Air Box

 Blue = intercooled products
 Black = non-intercooled products

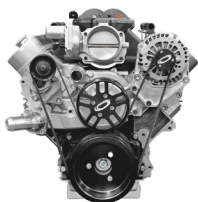

N/A DRIVE ONLY



N/A WITH P/S



N/A WITH ALL ACCESSORIES

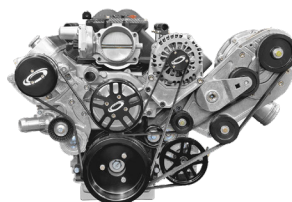

ALL ACCESS WITH SUPERCHARGER

LS / LT / SBC / BBC SERPENTINE ACCESSORY DRIVE KITS

NEW!

Year/Model	Part #	Description
specify	1LS300	Serp Acc Drive (with crank pulley + alternator bracket + water pump) - P/S & A/C optional
specify	1LS400	Serp Acc Drive (with P1SC1 / P-1X / D-1SC / D-1X / F-1A / F-1A-94 / F-1X / F-2)
specify	1LT300	Serp Acc Drive (with crank pulley + alternator bracket + water pump) - P/S & A/C optional
specify	1LT400	Serp Acc Drive (with P1SC1 / P-1X / D-1SC / D-1X / F-1A / F-1A-94 / F-1X / F-2)
SBC / BBC	1CA300/1CB300	Serp Acc Drive (with crank pulley + alternator bracket) - P/S & A/C optional
SBC / BBC	1CA400/1CB400	Serp Acc Drive (with P1SC1 / P-1X / D-1SC / D-1X / F-1A / F-1A-94 / F-1X / F-2)

LS SWAP SERPENTINE & COG RACE KITS (CARB/EFI)

Year/Model	Part #	HP Gain	Description
specify	1LS100-P-1SC-1 / P-1X / D-1SC / D-1X / F-1A / F-1A-94	specify	High Output with P-1SC-1 thru F-1A-94
specify	1LS100-P-1SC-1 / P-1X / D-1SC / D-1X-1 / F-1A / F-1A-94	specify	High Output Intercooled with P-1SC-1 thru F-1A-94
specify	1LS200-F-1 / F-1A / F-1A-94 / F-1R / F-1X / F-2	specify	Cog Kit with F-1 thru F-2
specify	1LS200-F-1 / F-1A / F-1A-94 / F-1R / F-1X / F-2-1	specify	Cog Kit with Intercooled F-1 thru F-2



Passenger side mount w/ C6 Corvette accessories



Driver side mount LS swap kit w/ LS1 accessories



Driver side mount w/ truck accessories

LT1/LT4 SWAP SERPENTINE KITS

Year/Model	Part #	HP Gain	Description
specify	1LT100-P-1SC1 / P-1X / D-1SC / D-1X / F-1A-94 / F-1X	specify	High Output with P-1SC-1 thru F-1X
specify	1LT100-P-1SC1 / P-1X / D-1SC / D-1X / F-1A-94 / F-1X-1	specify	High Output Intercooled with P-1SC-1 thru F-1X

SBC/BBC CHEVY KITS

Year/Model	Part #	HP Gain	Description
------------	--------	---------	-------------

SERPENTINE PROCHARGER DRIVE WITH V-BELT ACCESSORIES

specify	1CX100-P-1SC / P-1X / D-1SC / D-1X	specify	High Output (Intercooled available) with P-1SC thru D-1X (8 rib)
specify	1CX100-F-1 / F-1A / F-1A-94 / F-1R / F-1X / F-2	specify	High Output (Intercooled available) with F-1 thru F-2 (12 rib)

SERPENTINE PROCHARGER DRIVE WITH SERPENTINE ACCESSORIES

specify	1CX110-P-1SC / P-1X / D-1SC / D-1X	specify	High Output (Intercooled available) with P-1SC thru D-1X (8 rib)
specify	1CX110-F-1 / F-1A / F-1A-94 / F-1R / F-1X / F-2	specify	High Output (Intercooled available) with F-1 thru F-2 (12 rib)

COG PROCHARGER DRIVE WITH V-BELT ACCESSORIES

specify	1CX200-F-1 / F-1A / F-1A-94 / F-1R / F-1X / F-2	specify	Cog Race Kit (Intercooled available) with F-1D, F-1, F-1A
---------	---	---------	---

COG PROCHARGER DRIVE WITH SERPENTINE ACCESSORIES

specify	1CX210-F-1 / F-1A / F-1A-94 / F-1R / F-1X / F-2	specify	Cog Race Kit (Intercooled available) with F-1C, F-1R or F-1A-94
---------	---	---------	---

**BOLT ON
215+ HP**



CHALLENGER 392 (6.4 HEMI)

Year/Model	Part #	HP Gain	Description
2015-23	1DG515-SCI	200-215+	7 psi with P-1SC-1/P-1X
2015-23	1DG505-SCI	specify	Tuner Kit with P-1SC-1/D-1SC
2015-23	1DG415-SCI	200-215+	7 psi Stage II with P-1SC-1/P-1X
2015-23	1DG405-SCI	specify	Stage II Tuner Kit with P-1SC-1/D-1SC
2011-23	1DG314-SCI	200+	7 psi with P-1SC-1/P-1X
2011-23	1DG304-SCI	specify	Tuner Kit with P-1SC-1/D-1SC
2011-23	1DG214-SCI	200+	7 psi Stage II with P-1SC-1/P-1X
2011-23	1DG204-SCI	specify	Stage II Tuner Kit with P-1SC-1/D-1SC

Refer to ProCharger.com/streetlegal for the latest emissions certification details.



CHALLENGER (6.1 HEMI SRT8)

Year/Model	Part #	HP Gain	Description
2008-10	1DF314-SCI	160+	7 psi with P-1SC-1/P-1X
2008-10	1DF304-SCI	specify	Tuner Kit with P-1SC-1/D-1SC
2008-10	1DF214-SCI	160+	7 psi Stage II with P-1SC-1/P-1X
2008-10	1DF204-SCI	specify	Stage II Tuner Kit with P-1SC-1/D-1SC



CHALLENGER (5.7 HEMI R/T)

Year/Model	Part #	HP Gain	Description
2015-23	1DF615-SCI	160+	7 psi with P-1SC-1/P-1X
2015-23	1DF605-SCI	specify	Tuner Kit with P-1SC-1/D-1SC
2011-14	1DF414-SCI	160+	7 psi with P-1SC-1/P-1X
2011-14	1DF404-SCI	specify	Tuner Kit with P-1SC-1/D-1SC
2008-10	1DF314-SCI	130+	7 psi with P-1SC-1/P-1X
2008-10	1DF304-SCI	specify	Tuner Kit with P-1SC-1/D-1SC

Refer to ProCharger.com/streetlegal for the latest emissions certification details.



CHALLENGER (3.6)

Year/Model	Part #	HP Gain	Description
2015-23	1DQ214-SCI	40-45%+	7 psi with P-1SC-1
2015-23	1DQ204-SCI	specify	Tuner Kit with P-1SC-1/D-1SC



NOTES: D-1SC, D-1X, F-1D and F-1A models are available as an upgrade for all HEMI Tuner Kits. Optional P-1X Head Unit, Helical Gears and Polished or Black finish are available for Systems and Tuner Kits.

Blue = intercooled products
 Black = non-intercooled products

50 State Legal E.O. System



CHARGER 392 (6.4 HEMI)

Year/Model	Part #	HP Gain	Description
2015-23	1DI515-SCI 	200-215+	7 psi with P-1SC-1/P-1X
2015-23	1DI505-SCI	specify	Tuner Kit with P-1SC-1/D-1SC
2015-19	1DI415-SCI	200-215+	7 psi Stage II with P-1SC-1/P-1X
2015-19	1DI405-SCI	specify	Stage II Tuner Kit with P-1SC-1/D-1SC
2012-14	1DI314-SCI 	200+	7 psi with P-1SC-1/P-1X
2012-14	1DI304-SCI	specify	Tuner Kit with P-1SC-1/D-1SC



Refer to ProCharger.com/streetlegal for the latest emissions certification details.

V6 COMING SOON



CHARGER (6.1 HEMI SRT8)

Year/Model	Part #	HP Gain	Description
2006-10	1DD314-SCI 	160+	7 psi with P-1SC-1/P-1X
2006-10	1DD304-SCI	specify	Tuner Kit with P-1SC-1/D-1SC
2006-10	1DD214-SCI	160+	7 psi Stage II with P-1SC-1/P-1X
2006-10	1DD204-SCI	specify	Stage II Tuner Kit with P-1SC-1/D-1SC



Stage II System Shown

CHARGER (5.7 HEMI R/T)

Year/Model	Part #	HP Gain	Description
2015-23	1DI615-SCI 	160+	7 psi with P-1SC-1/P-1X
2015-23	1DI605-SCI	specify	Tuner Kit with P-1SC-1/D-1SC
2011-14	1DI414-SCI 	160+	7 psi with P-1SC-1/P-1X
2011-14	1DI404-SCI	specify	Tuner Kit with P-1SC-1/D-1SC
2006-10	1DD314-SCI 	110+/130+	7 psi with P-1SC-1/P-1X
2006-10	1DD304-SCI	specify	Tuner Kit with P-1SC-1/D-1SC
2006-08	1DD214-SCI	110+	7 psi Stage II with P-1SC-1/P-1X
2006-08	1DD204-SCI	specify	Stage II Tuner Kit with P-1SC-1/D-1SC







Refer to ProCharger.com/streetlegal for the latest emissions certification details.







300 (6.4/6.1/5.7 HEMI 3.6 V6)

Year/Model	Part #	HP Gain	Description
2011-23 (5.7)	1DK414-SCI 	160+	7 psi with P-1SC-1/P-1X
2011-23 (5.7)	1DK404-SCI	specify	Tuner Kit with P-1SC-1/D-1SC
2012-14 (6.4)	1DK314-SCI 	200+	7 psi with P-1SC-1/P-1X
2012-14 (6.4)	1DK304-SCI	specify	Tuner Kit with P-1SC-1/D-1SC
2005-10 (6.1)	1DE314-SCI 	160+	7 psi with P-1SC-1/P-1X
2005-10 (6.1)	1DE304-SCI	specify	Tuner Kit with P-1SC-1/D-1SC
2005-10 (5.7)	1DE314-SCI 	110+/130+	7 psi with P-1SC-1/P-1X
2005-10 (5.7)	1DE304-SCI	specify	Tuner Kit with P-1SC-1/D-1SC

Refer to ProCharger.com/streetlegal for the latest emissions certification details.



MAGNUM (6.1/5.7 HEMI)

Year/Model	Part #	HP Gain	Description
2005-08 (6.1)	1DE314-SCI 	160+	7 psi with P-1SC-1/P-1X
2005-08 (6.1)	1DE304-SCI	specify	Tuner Kit with P-1SC-1/D-1SC
2005-08 (5.7)	1DE314-SCI 	110+	7 psi with P-1SC-1/P-1X
2005-08 (5.7)	1DE304-SCI	specify	Tuner Kit with P-1SC-1/D-1SC

 50 State Legal E.O. System

 Blue = intercooled products
 Black = non-intercooled products

NOTES: D-1SC, D-1X, F-1D and F-1A models are available as an upgrade for all HEMI Tuner Kits. Optional P-1X model, Helical Gears and Polished finish upgrades are available for both Systems and Tuner Kits.

World's Fastest late model HEMI | 3.94 @ 184.72 mph, ProCharger F-3R-136 | First Gen III HEMI in the 3's



PROVEN TO PRODUCE THE LARGEST POWER GAINS

With the best and most reliable centrifugal supercharger systems available, it's no wonder that top racers across the nation choose ProCharger for their vehicles. With ProCharger's proven technology, our racers have accomplished a record-shattering 100+ national championships in the past 15 years. ProCharger powers over 90% of all centrifugal racers in the 7's, and the most centrifugal racers in the 6's and 5's (1/4 mile, and 1/8th mile equivalent). For serious racers, additional gains of over 1,000 hp are possible by switching to ProCharger.



BLOW-OFF VALVES

VALVES FOR STREET AND RACE APPLICATIONS



WHY ARE BLOW-OFF VALVES SO IMPORTANT?

More horsepower is associated with more airflow. It is important to get the air charge out of the tubing quickly when you let off of the throttle to avoid compressor surge and potential damage to the ProCharger Supercharger or other power adder, and help prevent other issues such as throttle hang, and belt snap on cog or serpentine driven applications. ProCharger currently has 5 different Blow-off Valve models available based on the needs of different applications.



STREET

ProFlow Valve: The ProFlow valve is the standard option for our street supercharger systems and kits. Compact in size, it can be fitted into tight spots when space is limited. Its butterfly valve is extremely durable and reliable, and this design creates a straight airflow path which achieves excellent flow for its size. The ProFlow valve can also be paired with a small air filter to minimize noise.

Bullet Valve: This valve's compact design also makes it fit easily in tight spaces. It comes in both an open and closed format. The closed format allows you to recirculate air back into the system, or instead to run to an air filter to minimize noise.

Competition Valve: Designed with the Pro Mod racer in mind; compact, light and fast acting. For use as a pair in applications above 3,000 HP.

RACE

Race Valve: This is the industry leading blow-off valve for both street and race applications. The larger valve diameter is designed for high flow applications. Now available in Red or Black.

ProRace Valve: One ProRace Valve outflows any other single valve on the market and is our highest-hp bypass valve option. This massive flow capacity comes from a piston style valve design (patent pending) that allows for a significant increase in curtain area over traditional style valves, while still fitting into a reasonably sized package. It also incorporates a v-band clamp for an easy install.

WATCH VIDEO ON BLOW-OFF SOUNDS AND SPECS



RACE BLOWERS



ProCharger CrankDrive™
F-4X-140 5.598 @ 258.96

NHRA Pro Mod World Champion

F-SERIES



**1ST AND ONLY
CENTRIFUGAL
LEGAL FOR
NHRA PRO MOD**

**HIGH
EFFICIENCY
RECORD
SETTING
RACE
BLOWERS**

Part#	Description	Max HP	Base HP	Max Boost
PC323A-001-A	F-1D ProCharger (satin)	1050	300-500	34 psi
PC324A-001-A	F-1 ProCharger (satin)	1050	300-500	38 psi
PC325A-001-A	F-1A ProCharger (satin)	1100	300-500	38 psi
PC335A-001-A	F-1A-91 ProCharger (satin)	1200	300-500	38 psi
PC336A-001-A	F-1A-94 ProCharger (satin)	1300	300-550	38 psi
PC327A-001-A	F-1C ProCharger (satin)	1100	300-550	38 psi
PC326A-001-A	F-1R ProCharger (satin)	1250	375-550	38 psi
PC330A-001-A	F-1X ProCharger (satin)	1400	375-550	38 psi
PC328A-002-A	F-2 ProCharger (satin)	1450	425-600	38 psi
PC314A-102-A	F-3D-102 ProCharger (satin)	1500	550-750	38 psi
PC314A-106	F-3D-106 ProCharger (satin)	1800	550-750	38 psi
PC314A-102-R	F-3R-102 ProCharger (satin)	1600	375-550	38 psi
PC314A-121R	F-3R-112 (F-1X-12) ProCharger (satin)	2100	CALL	38 psi
PC314A-121R	F-3R-121 ProCharger (satin)	2400	CALL	40 psi
PC314A-130	F-3R-130 ProCharger (satin)	2700	CALL	45 psi
PC314A-136	F-3R-136 ProCharger (satin)	3000	CALL	50 psi
PC314A-140	F-3R-140 ProCharger (satin)	3300	CALL	55 psi
PC317A-136	F-4R-136 ProCharger (satin)	3100	CALL	52 psi
PC318A-136	F-4X-136 ProCharger (satin)	3200	CALL	55 psi
PC318A-140	F-4X-140 ProCharger (satin)	3500+	CALL	60 psi
PC318A-141	F-4X-140-1 ProCharger (satin)	3700+	CALL	65 psi
PC318A-144	F-4X-144 ProCharger (satin)	4000+	CALL	70 psi
PC318A-145	F-4X-145 ProCharger (satin)	4200+	CALL	72 psi

**Precision Ground Steel Gears
Provide Industry-Leading
Durability and Step-Up Ratios**

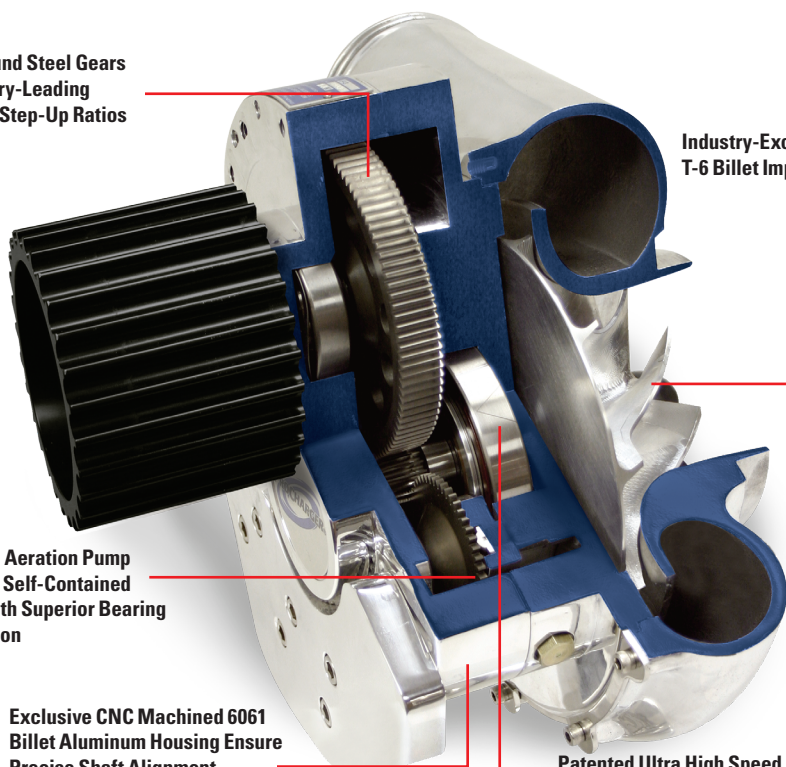

**Industry-Exclusive 7075
T-6 Billet Impeller**

**Patented Aeration Pump
Provides Self-Contained
Oiling with Superior Bearing
Lubrication**

**Exclusive CNC Machined 6061
Billet Aluminum Housing Ensure
Precise Shaft Alignment**

**Patented Ultra High Speed
Compound Bearing Assembly**

#PROCHARGER

CRANKDRIVE/RACEDRIVE

**PROCHARGER POWERS THE
WORLDS FASTEST CENTRIFUGAL
RACE CARS, 4500+ HP**

NHRA Top Dragster Champion



CRANKDRIVE™ GEAR DRIVE

Part#	Description
4CD-SBC-1 or 3	Chevrolet Small Block CrankDrive
4CD-BBC-1 or 3	Chevrolet Big Block CrankDrive
4CD-LSX-1 or 3	Chevrolet LSx CrankDrive
4CD-VED-1 or 3	Visner Small Block CrankDrive
4CD-BAE-3	BAE Hemi F-3 / F-4 CrankDrive
4CD-TFX-3	AJ TFX Hemi F-3 / F-4 CrankDrive
4CD-MBR-3	MBR F-3 / F-4 CrankDrive
4CD-SBF-1 or 3	Ford Small Block CrankDrive
4CD-BBF-1 or 3	Ford Big Block CrankDrive
4CD-COY-1 or 3	Ford Coyote CrankDrive
4CD-GOD-1 or 3	Ford Godzilla CrankDrive
4CD-481-3	481X F-3 / F-4 CrankDrive
4CD-NON-3	Noonan F-3 / F-4 CrankDrive

DETAILS AND DIMENSIONS CAN BE
FOUND AT PROCHARGER.COM



DRAGSTERDRIVE™ (CENTER MOUNT COG BELT)

Part#	Description
4DD-BBC-3	Chevrolet Big Block F-3 DragsterDrive (8mm Cog standard)

Call for availability on additional applications

REVERSE BELTDRIVE™ (CENTER MOUNT COG BELT)

Part#	Description
4BD-BBC-3	Chevrolet Big Block F-3 Reverse BeltDrive

Call for availability on additional applications

RACEDRIVE™ INTEGRATED SUPERCHARGER/GEAR DRIVE

Part#	Description	Max HP	Base HP	Max Boost
PC314A-12A-RD	with F-3R-112	2100	375-550	38 psi
PC314A-121-RD	with F-3R-121	2400	500-850	40 psi

**CHAMPIONSHIP PERFORMANCE
FOR NHRA TOP SPORTSMAN
AND TOP DRAGSTER**

RACE BELLMOUTH

ENGINEERED FOR MAXIMUM AIRFLOW
UNDER THE HARSHTEST RACE CONDITIONS

MORE AIRFLOW = BETTER PERFORMANCE



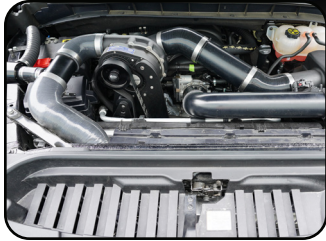

Refer to ProCharger.com/streetlegal for the latest emissions certification details.

2019-24 GM 1500 & 2021-24 SUV (6.2/5.3)

Year/Model	Part #	HP Gain	Description
2019-24 (5.3)	1KA213-SCI	45%+	8 psi with P-1SC-1/P-1X
2019-24 (5.3)	1KA202-SCI	specify	Tuner Kit with P-1SC-1/D-1SC
2019-24 (6.2)	1KA212-SCI	45%+	8 psi with P-1SC-1/P-1X
2019-24 (6.2)	1KA202-SCI	specify	Tuner Kit with P-1SC-1/D-1SC
2019-24 (5.3/6.2)	1KA312-SCI	45%+	Stage II with P-1SC-1/P-1X
2019-24 (5.3/6.2)	1KA302-SCI	specify	Stage II Tuner Kit with P-1SC-1/D-1SC
2021-24 (5.3)	1KB213-SCI	45%+	8 psi with P-1SC-1/P-1X
2021-24 (5.3)	1KB202-SCI	specify	Tuner Kit with P-1SC-1/D-1SC
2021-24 (6.2)	1KB212-SCI	45%+	8 psi with P-1SC-1/P-1X
2021-24 (6.2)	1KB202-SCI	specify	Tuner Kit with P-1SC-1/D-1SC
2021-24 (5.3/6.2)	1KB312-SCI	45%+	Stage II with P-1SC-1/P-1X
2021-24 (5.3/6.2)	1KB302-SCI	specify	Stage II Tuner Kit with P-1SC-1/P-1X

TRUCK
SUV

2020-24 GM 2500/3500 (6.6) SYSTEMS & KIT

Year/Model	Part #	HP Gain	Description
2020-24 (6.6)	1KA314-SCI	50-55%	6 psi with P-1SC-1/P-1X
2020-24 (6.6)	1KA414-SCI	55%+	Stage II with P-1SC-1/P-1X
2020-24 (6.6)	1KA304-SCI	specify	Tuner Kit with P-1SC-1/P-1X



2014-18 GM 1500 & 2015-20 SUV (6.2/5.3)

Year/Model	Part #	HP Gain	Description
2014-18 (5.3)	1GV213-SCI	45%+	8 psi with P-1SC-1/P-1X
2014-18 (5.3)	1GV202-SCI	specify	Tuner Kit with P-1SC-1/D-1SC
2014-18 (6.2)	1GV212-SCI	45%+	8 psi with P-1SC-1/P-1X
2014-18 (6.2)	1GV202-SCI	specify	Tuner Kit with P-1SC-1/D-1SC
2014-18 (5.3/6.2)	1GV312-SCI	45%+	Stage II with P-1SC-1/P-1X
2014-18 (5.3/6.2)	1GV302-SCI	specify	Stage II Tuner Kit with P-1SC-1/D-1SC



2015-19 GM 2500/3500 (6.0)

Year/Model	Part #	HP Gain	Description
2015-19 (6.0)	1GV314-SCI	45%+	7-8 psi with P-1SC-1
2015-19 (6.0)	1GV304-SCI	specify	Tuner Kit with P-1SC-1/D-1SC

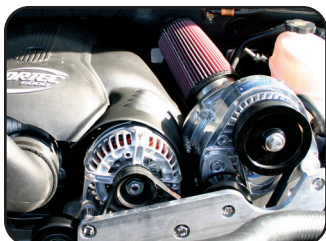

2007-13 GM (5.3/6.0/6.2/4.8)

Year/Model	Part #	HP Gain	Description
2007-13 (4.8/5.3)	1GR212-SCI	50-55%	8-9 psi with P-1SC-1/P-1X
2007-13 (4.8/5.3)	1GR202-SCI	specify	Tuner Kit with P-1SC-1/P-1X
2007-13 (4.8/5.3)	1GR312-SCI	50-55%	8-9 psi Stage II with P-1SC-1/P-1X
2007-13 (4.8/5.3)	1GR302-SCI	specify	Stage II Tuner Kit with P-1SC-1/P-1X
2007-13 (6.2)	1GR213-SCI	50%+	7-8 psi with P-1SC-1/P-1X
2007-13 (6.2)	1GR202-SCI	specify	Tuner Kit with P-1SC-1/P-1X
2007-09 (6.0)	1GR212-SCI	50%+	7-8 psi with P-1SC-1/P-1X
2007-09 (6.0)	1GR202-SCI	specify	Tuner Kit with P-1SC-1/P-1X
2007-13 (6.0/6.2)	1GR312-SCI	50%+	Stage II with P-1SC-1/P-1X
2007-13 (6.0/6.2)	1GR302-SCI	specify	Stage II Tuner Kit with P-1SC-1/P-1X



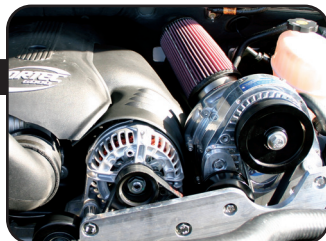

2003-07 GM (5.3/6.0/6.2/4.8)

Year/Model	Part #	HP Gain	Description
2003-07 (4.8/5.3)	1GI213-SCI	60-65%	8-9 psi with P-1SC
2003-07 (6.0)	1GI213-SCI	55-60%	7-8 psi with P-1SC
2003-07	1GI203-SCI	specify	Tuner Kit with P-1SC
2003-07 (5.3/4.8/6.0)	Call Us	specify	Stage II Tuner Kit with P-1SC-1/P-1X



1999-03 GM (5.3/6.0/4.8)



Year/Model	Part #	HP Gain	Description
1999-03 (5.3/4.8)	1GI212-SCI 	60-65%	8-9 psi with P-1SC
1999-03 (6.0)	1GI212-SCI 	55-60%	7-8 psi with P-1SC
1999-03 (5.3/4.8/6.0)	1GI202-SCI	specify	Tuner Kit with P-1SC
1999-03 (5.3/4.8/6.0)	Call Us	specify	Stage II Tuner Kit with P-1SC-1/P-1X



Refer to ProCharger.com/streetlegal for the latest emissions certification details.



1988-00 GM (5.7/7.4)

Year/Model	Part #	HP Gain	Description
1996-00 (5.7)	1GH212-SCI 	60-65%	8-9 psi with P-1SC
1996-00 (5.7)	1GH202-SCI	specify	Tuner Kit with P-1SC/D-1SC
1996-00 (7.4)	1GG202-SCI	specify	Tuner Kit with P-1SC/D-1SC
1988-95 (5.7)	1GD212-SCI 	60-65%	8-9 psi with P-1SC
1988-95 (5.7)	1GD202-SCI	60-65%	Tuner Kit with P-1SC
1988-95 (5.7)	1GD212-09I	60-65%	8-9 psi with P600B
1988-95 (7.4)	1GE212-SCI 	60-65%	8-9 psi with P-1SC
1988-95 (7.4)	1GE202-SCI	60-65%	Tuner Kit with P-1SC
1988-95 (7.4)	1GE212-09I	60-65%	8-9 psi with P600B

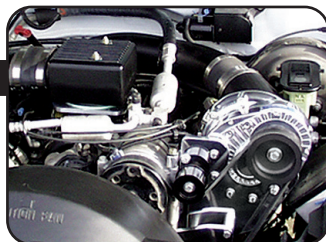

HUMMER H2 (6.2/6.0)

Year/Model	Part #	HP Gain	Description
2008-09 (6.2)	1GL302-SCI	specify	Tuner Kit with P-1SC-1/D-1SC
2003-07 (6.0)	1GL202-SCI	specify	Tuner Kit with P-1SC/D-1SC

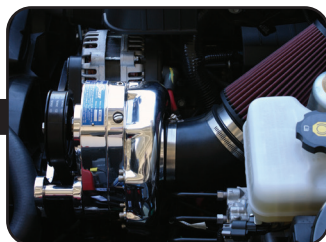

 Blue = intercooled products
 Black = non-intercooled products



F-150/SUPER DUTY



NEW!

2021-25 FORD F-150 (5.0 4V)



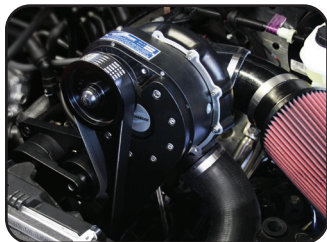

Optional Black Finish Shown

Year/Model	Part #	HP Gain	Description
2021-25	1EA411-SCI	65-70%	10 psi with P-1SC-1
2021-25	1EA401-SCI	specify	Tuner Kit with P-1SC-1
2021-25	1EA511-SCI	75-80%	12 psi Stage II with P-1SC-1
2021-25	1EA501-SCI	specify	Stage II Tuner Kit with P-1SC-1



Optional Black Finish Shown

2015-20 FORD F-150 (5.0 4V)



Year/Model	Part #	HP Gain	Description
2018-20	1FY411-SCI	50-55%	6 psi with P-1SC-1/P-1X
2018-20	1FY401-SCI	specify	Tuner Kit with P-1SC-1/P-1X
2018-20	1FY511-SCI	60-65%	8 psi Stage II with P-1SC-1/P-1X
2018-20	1FY501-SCI	specify	Stage II Tuner Kit with P-1SC-1/P-1X
2015-17	1FY211-SCI 	45-55%	6-7 psi with P-1SC-1/P-1X
2015-17	1FY201-SCI	specify	Tuner Kit with P-1SC-1/D-1SC
2015-17	1FY311-SCI 	60-70%	8-9 psi Stage II with P-1SC-1/P-1X
2015-17	1FY301-SCI	specify	Stage II Tuner Kit with P-1SC-1/D-1SC

Refer to ProCharger.com/streetlegal for the latest emissions certification details.



Forward-Facing Air Inlet Shown

2011-14 FORD F-150 (5.0/6.2 4V)

Year/Model	Part #	HP Gain	Description
2011-14 (5.0)	1FV211-SCI 	45-55%	6-7 psi with P-1SC-1/P-1X
2011-14 (5.0)	1FV201-SCI	specify	Tuner Kit with P-1SC-1/D-1SC
2011-14 (5.0)	1FV311-SCI 	60-70%	8-9 psi Stage II with P-1SC-1/P-1X
2011-14 (5.0)	1FV301-SCI	specify	Stage II Tuner Kit with P-1SC-1/D-1SC
2011-14 (6.2)	1FS311-SCI	50%+	7-8 psi with D-1SC
2011-14 (6.2)	1FS301-SCI	specify	Tuner Kit with D-1SC
2011-14 (6.2)	1FS211-SCI 	50%+	7-8 psi Stage II with P-1SC-1/P-1X
2011-14 (6.2)	1FS201-SCI	specify	Stage II Tuner Kit with P-1SC-1/D-1SC



2020-23 FORD SUPER DUTY (7.3)

Year/Model	Part #	HP Gain	Description
2020-23	1FZ211-SCI	45%+	7-8 psi with P-1SC-1
2020-23	1FZ201-SCI	specify	Tuner Kit with P-1SC-1



2010-14 FORD RAPTOR (6.2/5.4)

Year/Model	Part #	HP Gain	Description
2010-14 (6.2)	1FS311-SCI	50%+	7-8 psi with D-1SC
2010-14 (6.2)	1FS301-SCI	specify	Tuner Kit with D-1SC
2010-14 (6.2)	1FS211-SCI	50%+	7-8 psi Stage II with P-1SC-1/P-1X
2010-14 (6.2)	1FS201-SCI	specify	Stage II Tuner Kit with P-1SC-1/D-1SC
2010 (5.4)	1FS211-SCI	60%+	8-9 psi with P-1SC-1/P-1X
2010 (5.4)	1FS201-SCI	specify	Tuner Kit with P-1SC-1/D-1SC



**CALL FOR 2015-20 F-150/RAPTOR
ECOBOOST INTERCOOLER UPGRADES**

2009-10 FORD F-150 (5.4 3V)

Year/Model	Part #	HP Gain	Description
2009-10	1FN211-SCI	60-65%	8-9 psi with P-1SC-1/P-1X
2009-10	1FN201-SCI	specify	Tuner Kit with P-1SC-1/D-1SC



2004-08 FORD (5.4 3V)

Year/Model	Part #	HP Gain	Description
2004-08 F-150	1FN211-SCI	60-65%	8-9 psi with P-1SC-1
2004-08 F-150	1FN201-SCI	specify	Tuner Kit with P-1SC-1/D-1SC
2007-08 Expedition	1FN211-SCI	60-65%	8-9 psi with P-1SC-1
2007-14 Expedition	1FN201-SCI	specify	Tuner Kit with P-1SC-1/D-1SC



1997-03 FORD (5.4/4.6 2V)

Year/Model	Part #	HP Gain	Description
1997-03 (5.4)	1FG211-SCI	60-65%	8-9 psi with P-1SC (F-150/Expedition)
1997-03 (5.4)	1FG201-SCI	specify	Tuner Kit with P-1SC (F-150/Expedition)
1997-03 (4.6)	1FH211-SCI	60-65%	8-9 psi with P-1SC (F-150/Expedition)
1997-03 (4.6)	1FH201-SCI	specify	Tuner Kit with P-1SC (F-150/Expedition) (Excludes 2003 Expedition)



Blue = intercooled products
 Black = non-intercooled products

50 State Legal E.O. System



1500/2500

CALL FOR DETAILS REGARDING
LATEST MODEL YEARS



2500



1500

RAM (1500 5.7 HEMI)



Year/Model	Part #	HP Gain	Description
2019-23	1DP314-SCI	140+	7 psi with D-1SC
2019-23	1DP304-SCI	specify	Tuner Kit with D-1SC
2019-23	1DP315-SCI	140+	7 psi with P-1SC-1 (dedicated 8-rib drive)
2019-23	1DP305-SCI	specify	Tuner Kit with P-1SC-1 (dedicated 8-rib drive)
2019-23	1DP415-SCI	140+	7 psi with P-1SC-1 (eTorque)
2019-23	1DP405-SCI	specify	Tuner Kit with P-1SC-1 (eTorque)

RAM (2500/3500 6.4 HEMI)



Year/Model	Part #	HP Gain	Description
2019-23	1DN312-SCI	130+	6 psi with D-1SC
2019-23	1DN302-SCI	specify	Tuner Kit with D-1SC
2014-18	1DN212-SCI	130+	6 psi with D-1SC
2014-18	1DN202-SCI	specify	Tuner Kit with D-1SC

RAM CLASSIC (5.7 HEMI)

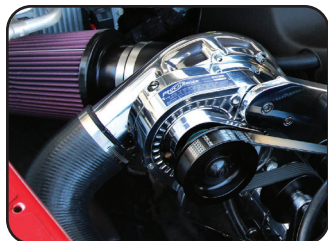

Year/Model	Part #	HP Gain	Description
2011-23	1DH314-SCI	140+	7 psi with D-1SC
2011-23	1DH304-SCI	specify	Tuner Kit with D-1SC
2009-23	1DH315-SCI	130+/140+	7 psi Stage II with P-1SC-1
2009-23	1DH305-SCI	specify	Stage II Tuner Kit with P-1SC-1
2009-10	1DH214-SCI	130+	7 psi with P-1SC-1
2009-10	1DH204-SCI	specify	Tuner Kit with P-1SC-1/D-1SC

Refer to ProCharger.com/streetlegal for the latest emissions certification details.

50 State Legal E.O. System





DODGE RAM (5.7 HEMI)

Year/Model	Part #	HP Gain	Description
2004-08	1DC214-SCI 	45-50%	6 psi with P-1SC-1
2004-08	1DC204-SCI	specify	Tuner Kit with P-1SC-1/D-1SC



DODGE TRUCK (5.9/5.2)

Year/Model	Part #	HP Gain	Description
1996-01 (Ram)	1DA202-SCI	55-60%	8-9 psi with P-1SC
1997-01 (Dakota/Durango)	1DB202-SCI	55-60%	8-9 psi with P-1SC

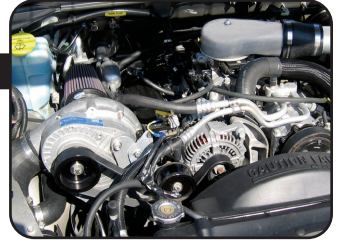

**DURANGO SRT
BOLT ON 215+ HP**

DURANGO (6.4 HEMI SRT)

Year/Model	Part #	HP Gain	Description
2018-23	1DL215-SCI 	215+	7 psi with P-1SC-1/P-1X
2018-23	1DL205-SCI	specify	Tuner Kit with P-1SC-1/P-1X

Refer to ProCharger.com/streetlegal for the latest emissions certification details.

DURANGO 5.7 L COMING SOON!



-  Blue = intercooled products
-  Black = non-intercooled products





GLADIATOR JT (3.6)

Year/Model	Part #	HP Gain	Description
2020-23	1JT214-SCI 	40-45%+	7 psi with P-1SC-1
2020-23	1JT204-SCI	specify	Tuner Kit with P-1SC-1/D-1SC

Refer to ProCharger.com/streetlegal for the latest emissions certification details.



WRANGLER JL (3.6)

Year/Model	Part #	HP Gain	Description
2018-23	1JL214-SCI 	40-45%+	7 psi with P-1SC-1
2018-23	1JL204-SCI	specify	Tuner Kit with P-1SC-1/D-1SC

Refer to ProCharger.com/streetlegal for the latest emissions certification details.

NOTE: 2021 JL model year is currently manual transmissions only. Call for more info.



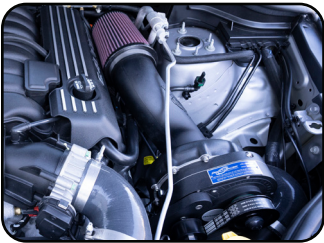

WRANGLER JK (3.6)

Year/Model	Part #	HP Gain	Description
2012-18	1JK214-SCI 	50%+	7 psi with P-1SC-1
2012-18	1JK204-SCI	specify	Tuner Kit with P-1SC-1/D-1SC



GRAND CHEROKEE (6.4/5.7 HEMI)



Year/Model	Part #	HP Gain	Description
2012-20 (6.4)	1DL214-SCI 	215+	7 psi with P-1SC-1/P-1X
2012-20 (6.4)	1DL204-SCI	specify	Tuner Kit with P-1SC-1/D-1SC
2011-21 (5.7)	1DM214-SCI 	160+	7 psi with P-1SC-1/P-1X
2011-21 (5.7)	1DM204-SCI	specify	Tuner Kit with P-1SC-1/P-1X

Refer to ProCharger.com/streetlegal for the latest emissions certification details.

CALL FOR 2022 WAGONEER



GRAND CHEROKEE (6.1 HEMI SRT8)

Year/Model	Part #	HP Gain	Description
2006-10	1DJ214-SCI 	160+	7 psi with P-1SC-1
2006-10	1DJ204-SCI	specify	Tuner Kit with P-1SC-1/D-1SC
2006-10	1DJ314-SCI 	160+	7 psi Stage II with P-1SC-1/P-1X
2006-10	1DJ304-SCI	specify	Stage II Tuner Kit with P-1SC-1/D-1SC

 Blue = intercooled products
 Black = non-intercooled products

 50 State Legal E.O. System



4RUNNER (4.0)

Year/Model	Part #	HP Gain	Description
2010-24	1TK212-SCI 	40-45%	7-8 psi with D-1SC
2010-24	1TK202-SCI	specify	specify

Refer to ProCharger.com/streetlegal for the latest emissions certification details.



TACOMA (3.5)

Year/Model	Part #	HP Gain	Description
2016-23	1TM212-SCI 	40-45%	7-8 psi with D-1SC
2016-23	1TM202-SCI	specify	specify

Refer to ProCharger.com/streetlegal for the latest emissions certification details.



TACOMA (4.0)

Year/Model	Part #	HP Gain	Description
2005-15	1TL212-SCI 	40-45%	7-8 psi with D-1SC
2005-15	1TL202-SCI	specify	specify

Refer to ProCharger.com/streetlegal for the latest emissions certification details.



TOYOTA TUNDRA (5.7) COMING SOON





POLARIS SLINGSHOT

Year/Model	Part #	HP Gain	Description
2015-19	1PD112-SCI	55%+	8 psi with CS-1
2015-19	1PD102-SCI	specify	Tuner Kit with CS-1

For the most up-to-date listing of ProCharger-based "Third Party Kits" for other Powersports applications, visit: www.procharger.com/powersports and click on the link for Third Party Kits

SPORT COMPACT

NISSAN 350Z

Year/Model	Part #	HP Gain	Description
2003-06	1NB202-SCI	55-60%	Tuner Kit with C-2

INFINITI G35 AND FX35

Year/Model	Part #	HP Gain	Description
2003-04 G35	1NC202-SCI	45-50%	Tuner Kit with C-2
2003-04 FX 35	1NC202-SCI	45-50%	Tuner Kit with C-2

ACURA INTEGRA (1.8L)

Year/Model	Part #	HP Gain	Description
1994-01	1HB202-SCI	70-75%	Tuner Kit with C-1A

HONDA CIVIC SI (1.6L)

Year/Model	Part #	HP Gain	Description
1999-00	1HA202-SCI	70-75%	Tuner Kit with C-1A

FORD FOCUS

Year/Model	Part #	HP Gain	Description
2000-03 (Zetec)	1FK202-SCI	65-80%	Tuner Kit with C-1B
2002-04 (SVT)	1FN302-SCI	65-80%	Tuner Kit with C-1B





Performance
Product
of the Year



200+ HP
Bagger



**BOLT ON
70-75%
MORE
POWER**



NEW!

TOURING

Year	Part#	Engine	HP Gain	Description
2017-23	1BL500	Milwaukee Eight 107, 114+	specify	HO Intercooled ProCharger Tuner Kit
2017-23	1BL512	Milwaukee Eight 107, 114+	70-75%	HO Intercooled ProCharger System
2007-16	1BL300	Twin Cam 96, 103, 110+	specify	HO Intercooled ProCharger Tuner Kit
2007-16	1BL312	Twin Cam 96, 103	70-75%	HO Intercooled ProCharger System
2002-06	1BL200	Twin Cam 88	specify	HO Intercooled ProCharger Tuner Kit
2002-06	1BL212	Twin Cam 88	70-75%	HO Intercooled ProCharger System
1994-01	1BL400	Twin Cam 88	specify	HO Intercooled ProCharger Tuner Kit
1994-06	1BL100	Evo/Twin Cam 88+ (Carb)	specify	HO Intercooled ProCharger Tuner Kit
1994-06	1BL112	Evo/Twin Cam 88+ (Carb)	70-75%	HO Intercooled ProCharger System

SOFTAIL

Year	Part#	Engine	HP Gain	Description
2007-17	1BA300	Twin Cam 96, 103, 110+	specify	HO Intercooled ProCharger Tuner Kit
2007-17	1BA312	Twin Cam 96, 103	70-75%	HO Intercooled ProCharger System
2001-06	1BA200	Twin Cam 88B, 95, 103+	specify	HO Intercooled ProCharger Tuner Kit
2001-06	1BA212	Twin Cam 88B	70-75%	HO Intercooled ProCharger System
1994-06	1BA200	Evo/Twin Cam 88+ (Carb)	specify	HO Intercooled ProCharger Tuner Kit
1994-06	1BX101	Evo/Twin Cam 88+ (Carb)	70-75%	HO Intercooled ProCharger System

**2018+
SOFTAIL
COMING
SOON**

DYNA

Year	Part#	Engine	HP Gain	Description
2006-17	1BB300	Twin Cam 96, 103, 110+	specify	HO Intercooled ProCharger Tuner Kit
2006-17	1BB312	Twin Cam 96, 103, 110+	70-75%	HO Intercooled ProCharger System
2004-05	1BB200	Twin Cam 96, 103, 110+	specify	HO Intercooled ProCharger Tuner Kit
2004-05	1BB212	Twin Cam 96, 103, 110+	70-75%	HO Intercooled ProCharger System
1999-05	1BB200	Twin Cam 88+ (Carb)	specify	HO Intercooled ProCharger Tuner Kit
1999-05	1BX102	Twin Cam 88+ (Carb)	70-75%	HO Intercooled ProCharger System

PROCHARGER SYSTEMS AVAILABLE FOR:

Mercury 525 EFI, 500 EFI & HP 500; MerCruiser 496 Mag, 496 Mag HO, 502 Mag MPI, 454 Mag MPI, 7.4 MPI, 6.2 MPI, 5.7 MPI and carbureted engines with additional applications coming soon, call for details.

■ Blue = intercooled products
■ Black = non-intercooled products



PROCHARGER IN THE MEDIA

The media, from magazines, websites and video content producers to even video games love ProCharger and regularly feature our superchargers and systems. On our website "click the videos tab" to see a bunch of examples of small screen appearances in "Engine Power TV," Stacey David's "Gearz," "Street Outlaws," ESPN's "Inside Drag Racing," YouTubes "Off The Ranch (Demolition Ranch)," "Vice Grip Garage," "Goonzquad," and "1320 Video," as well as other video appearances on YouTube.



APPAREL, PARTS, INFO, & MORE!

Check out our website for more application-specific information about our complete line of supercharger systems and vehicle galleries where you can create your own gallery entry with your ProCharger-powered car, truck, race car, motorcycle, ATV or boat!

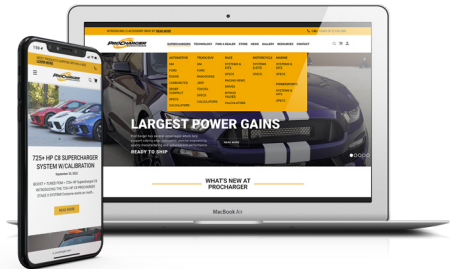

Shop our large selection of supercharger-related parts and ProCharger merch at procharger.com.





STATE-OF-THE-ART TEST FACILITY

ProCharger's aerodynamics test lab utilizes state of the art equipment and three separate test cells to help ensure that ProCharger superchargers are the best available. This test lab, the industry's largest and most capable, allows ProCharger engineers to simultaneously perform aerodynamic (efficiency), gearcase, and long term durability testing. A hallmark of ProCharger's success has been a thorough understanding of engine dynamics and customer usage, both on the street and at the track. This helps ensure that testing in the lab, on the dyno, at the track and on the road are all representative of real world performance. The result has been a best-in-class history of innovation, and record setting products. Additionally, knowledge transferred from Inovair, ATI's industrial products division, which features gearcases designed for nonstop 24/7 operation and compressor efficiencies exceeding 80%, now helps fuel further advances by ProCharger.



STAY UP TO SPEED

Keep up with all the latest news, events and amazing, real-world customer and racer accomplishments via the ProCharger Blog, at ProCharger.com/blog.



**SCAN HERE FOR MORE
INFO ON OUR BLOG**



ProCharger Office, Mill Valley, California

ProCharger® and The Ultimate Power Adder® are registered trademarks of Accessible Technologies, Inc. Chevy®/GM® are registered trademarks of General Motors and are used for descriptive purposes only; Ford® is a registered trademark of Ford Motors and is used for descriptive purposes only; Toyota® is registered trademarks of Toyota Industries and are used for descriptive purposes only; Polaris is a registered trademark for Polaris Industries and is used for descriptive purposes only; Arctic Cat is a registered trademark for Arctic Cat/Textron and is used for descriptive purposes only; MerCruiser and Mercury Marine are registered trademarks for Mercury Marine and are used for descriptive purposes only; Chrysler®/Dodge®/Ram®/Hemi®/Jeep® are registered trademarks of Fiat Chrysler Automobiles N.V. and is used for descriptive purposes only.

ProCharger Headquarters Campus, Kansas City





BRAND AND CATEGORY SPECIFIC CATALOGS AVAILABLE AT PROCHARGER.COM



INVENTED, ENGINEERED AND MADE IN THE USA



#PROCHARGER

All of us at ATI encourage you to use your newfound ProCharger power responsibly. Please drive safely and be respectful of your fellow motorists. If you feel the need to race, don't do it on the street—take it to the track!

© Copyright 2024, Accessible Technologies, Inc. 10/24

Sales: sales@procharger.com | Technical Service: ts@procharger.com | Customer Service: cs@procharger.com