

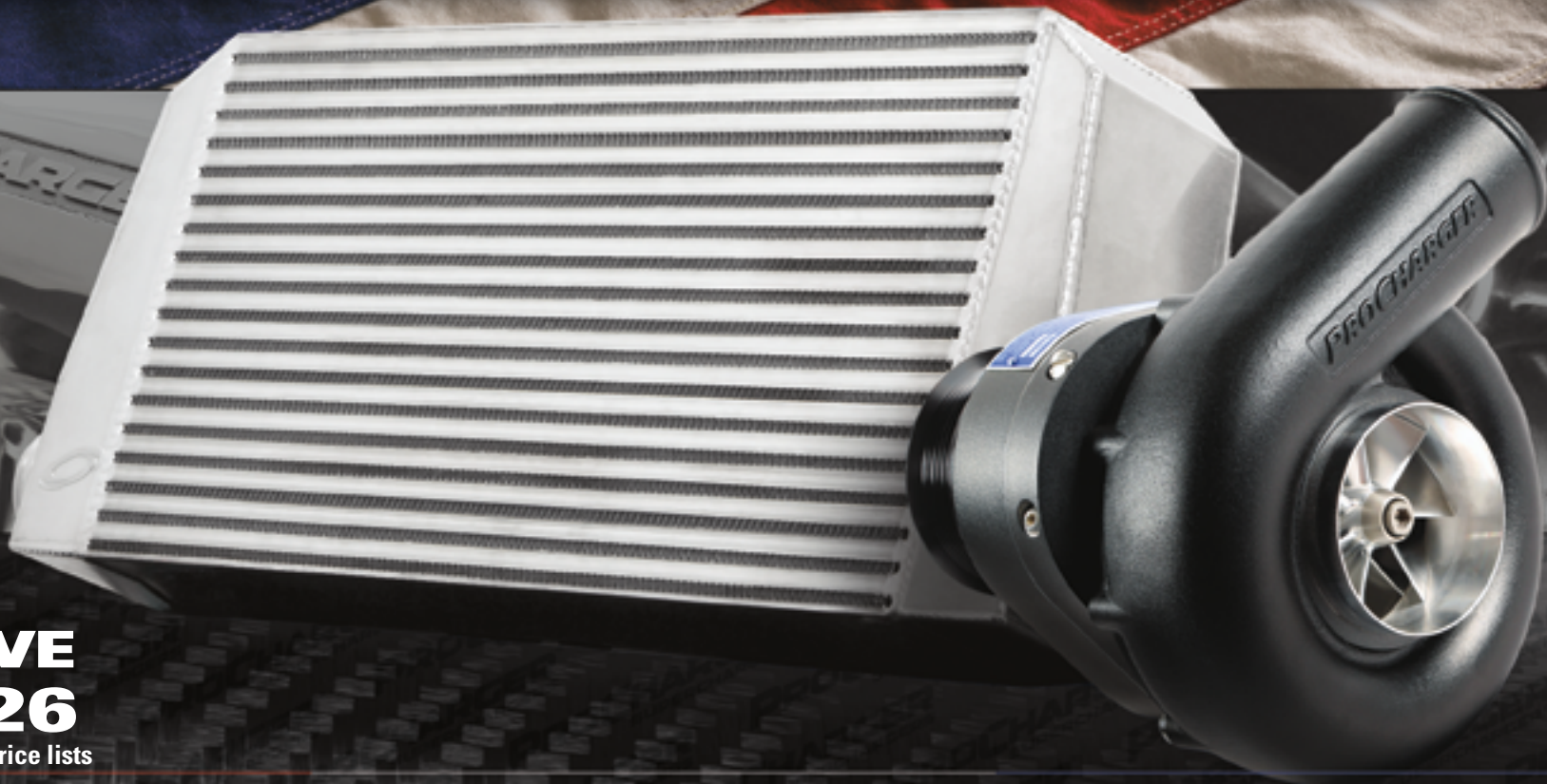

AUTOMOTIVE & TRUCK/SUV

APPLICATIONS, SPECIFICATIONS, AND RETAIL PRICE GUIDE



EFFECTIVE
04/30/26

Supersedes all previous price lists

PROUD SUPPORTERS OF



FORD AUTOMOTIVE

NEW 2024-26 Mustang GT, Perf. Pack, Darkhorse (5.0)	4
UPDATED 2018-23 Mustang GT (5.0 4V)	4
UPDATED 2021-23 Mach 1, Bullitt (5.0 4V)	4
UPDATED 2015-20 GT350 and GT350R (5.2 4V)	6
UPDATED 2015-17 Mustang GT (5.0 4V)	6
2015-17 Mustang V6 (3.7 4V)	6
2011-14 Mustang GT and i-1 (5.0 4V)	8
2011-14 Mustang V6 (3.7 4V)	8
2012-13 Boss 302 Mustang (5.0 4V)	8
2005-10 Mustang GT (4.6 3V)	10
2005-10 Mustang V6 (4.0)	10
1999-04 Mustang GT and 2001 Bullitt (4.6 2V)	12
2003-04 Mustang Mach 1 (4.6 4V)	12
1996-98 Mustang GT (4.6 2V)	12
1994-04 Mustang V6 (3.8, 3.9)	12
1996-04 Cobra (4.6 4V)	14
1994-95 Mustang, Cobra (5.0)	16
1986-93 Mustang, Cobra (5.0)	16
NEW SBF Serpentine Accessory Drive Kit	18
1964½-66 Early Ford Kits (289/302)	20
SBF Classic Serpentine Kits	20
SBF Cog Race Kits	22
Coyote, Godzilla Engine Swap Kits	24

CHEVROLET/PONTIAC/GM AUTOMOTIVE

2020-26 Corvette C8 Stingray (LT2)	26
NEW 2024-26 Corvette C8 E-Ray (Hybrid)	26
2014-19 Corvette C7 Stingray/Grand Sport (LT1)	28
2015-19 Corvette C7 Z06 (LT4), Stingray (LT1)	28
2008-13 Corvette C6 (LS3)	30
2006-13 Corvette C6 Z06 (LS7)	30
2005-07 Corvette C6 (LS2)	30
1997-04 Corvette C5, Z06 (LS1, LS6)	32
1985-96 Corvette C4 (LT1, LT4, TPI L98)	36
2016-24 Camaro SS (LT1)	34
2017-21 Camaro ZL1 (LT4)	34
2016-24 Camaro V6 (3.6)	34
2014-15 Camaro Z/28 (LS7)	36
2010-15 Camaro SS (LS3, L99)	36
2010-15 Camaro SS Cog Race Kits	36
1998-02 Camaro/Firebird (LS1)	38
1993-97 Camaro/Firebird (LT1)	38
1987-92 Camaro/Firebird TPI (L98)	38
2016-19 Cadillac CTS-V (LT4)	40
2014-17 Chevrolet SS	40
2008-09 Pontiac G8 GT	40
2004-06 Pontiac GTO (LS1, LS2)	40
LS/LT Serpentine Accessory Drive Kit	42
LS Engine Swap Classic Serpentine/Cog Race Kits	44
LS Reverse Passenger Side Engine Swap Kits	46
LT1/LT4 Classic Serpentine Kits (2014+)	46
SBC/BBC Serpentine Accessory Drive Kit	48
SBC/BBC Classic Serpentine and Cog Kits	50-53

DODGE/CHRYSLER AUTOMOTIVE

2011-23 Dodge Challenger HEMI (6.4)	54
2011-23 Dodge Challenger HEMI (5.7)	54
2015-23 Dodge Challenger V6 (3.6)	54
2008-10 Dodge Challenger HEMI SRT8 (6.1)	56
2008-10 Dodge Challenger HEMI R/T (5.7)	56
2012-23 Dodge Charger HEMI SRT8 (6.4)	58
2011-23 Dodge Charger HEMI R/T (5.7)	58
2015-23 Dodge Charger V6 (3.6)	58
2006-10 Dodge Charger HEMI SRT8 (6.1)	60
2006-10 Dodge Charger HEMI R/T (5.7)	60
2012-14 Chrysler 300 HEMI SRT8 (6.4)	62
2011-23 Chrysler 300 HEMI (5.7)	62
2005-10 Chrysler 300 HEMI (5.7, 6.1)	62
2005-08 Dodge Magnum HEMI (6.1)	62
2005-08 Dodge Magnum HEMI (5.7)	62

FORD TRUCK/SUV

NEW 2024-26 Ford F-150 (5.0 4V)	64
UPDATED 2021-23 Ford F-150 (5.0 4V)	64
NEW 2020-25 Ford Super Duty (7.3)	64
2015-20 Ford F-150 (5.0 4V)	66
2011-14 Ford F-150 (5.0, 6.2 4V)	66
2010-14 Ford F-150 SVT Raptor (5.4, 6.2 3V)	68
2004-10 Ford F-150 and Expedition (5.4 3V)	68
1997-03 Ford F-150 and Expedition (5.4, 4.6 2V)	68
NEW 1988-96 Ford F-150, Bronco (5.0, 5.8)	68
Coyote Engine Swap 92-96 Truck Kits	68

GM TRUCK/SUV

NEW 2019-26 GM Truck 1500 (5.3, 6.2)	70
NEW 2021-26 GM SUV (5.3, 6.2)	70
NEW 2020-26 GM Truck 2500 (6.6)	70
2014-18 GM Truck 1500 (5.3, 6.2)	72
2015-20 GM SUV (5.3, 6.2)	72
2015-19 GM Truck 2500 (6.0)	72
2007-13 GM Truck 1500 (4.8, 5.3, 6.0, 6.2)	74
2007-13 GM SUV (4.8, 5.3, 6.0, 6.2)	74
2007-11 GM Truck 2500 (6.0)	74
1999-07 GM Truck 1500 Classic (4.8, 5.3, 6.0)	76
1999-07 GM Truck 2500 Classic (6.0)	76
1999-03 GM Truck/SUV (4.8, 5.3, 6.0)	76
2003-09 Hummer H2 (6.0, 6.2)	78
1996-00 GM Truck/SUV (5.7, 7.4)	78
1988-95 GM TBI Truck/SUV (5.7, 7.4)	78

DODGE/RAM TRUCK/SUV

2011-24 Ram Classic / 1500 / eTorque (5.7)	80
2014-24 Ram 2500/3500 and Power Wagon (6.4)	80
2004-10 Ram Classic (5.7)	80
1996-01 Dodge Ram (5.2, 5.9)	80
2018-25 Dodge Durango SRT (5.7, 6.4)	82
1997-01 Dodge Dakota/Durango (5.2, 5.9)	82

JEEP

2012-21 Jeep Grand Cherokee SRT (6.4)	84
2011-21 Jeep Grand Cherokee (5.7)	84
2006-10 Jeep Grand Cherokee SRT8 (6.1)	84
2020-25 Jeep Gladiator JT (3.6)	84
2018-25 Jeep Wrangler JL (3.6)	84
2012-18 Jeep Wrangler JK (3.6)	84

TOYOTA

2010-24 4Runner (4.0)	86
2016-23 Tacoma (3.5)	86
2005-15 Tacoma (4.0)	86

SPORT COMPACT

2015-19 Polaris Slingshot	88
2003-06 Nissan 350Z (3.5)	88
2003-04 Infiniti G35 Coupe, FX35 (3.5)	88
1999-00 Honda Civic Si (1.6L DOHC)	88
1994-01 Acura Integra GSR Type R (1.8L DOHC)	88
2000-04 Ford Focus (Zetec, SVT)	88

GENERAL INFORMATION

Street/Strip Supercharger Specifications	90
Race Supercharger Specifications	91
Superchargers	92
Parts, Accessories, & Racing Products	93
Universal Intercoolers	94
NEW Intake Manifolds, Carb Hats	95

CALL REGARDING NEW MODEL YEARS



DEFINITIONS, TERMS & CONDITIONS



PROCHARGER COMPLETE SYSTEMS

- Systems are sold 100% complete unless noted otherwise.
- Systems are designed for operation on vehicles with stock engines and stock exhaust.
- For a given application, there may be multiple tiers of Systems - High Output, Stage 1, Stage 2 / II, etc - to accommodate higher power levels.
- Tuning is available for Systems only, and only for vehicles with stock engines with stock exhaust, as well as most "cat-back" exhaust systems.
- Boost level and performance may change based on elevation.
- Complete systems with tuning require a minimum of US 91 octane gas.
- All engine and exhaust modifications must be noted at time of order. ProCharger is not responsible for boost levels or tuning for modified applications.
- Vehicles built for export and other non-US spec vehicles may require custom tuning/calibrations.
- ProCharger systems for stock vehicles are emissions legal in all 50 states where noted in the "CARB EO" column in the product specs. For compliance information, visit www.arb.ca.gov
- Due to variability among OEM computers, the prevalence of custom modifications, and age/miles/condition of vehicles, dyno tuning may be required; stock vehicles with cat-back exhaust systems may require custom tuning.

PROCHARGER TUNER KITS

- ProCharger Tuner Kits exclude fuel components and computer programming, but are otherwise identical to complete systems.
- Tuner Kits are designed for both stock and modified vehicles.
- For a given application, there may be multiple tiers of Tuner Kits - High Output, Stage 1, Stage 2 / II, etc. - to accommodate higher power levels.
- Race kits and components are intended for off-road/racing use only and may require modifications, trimming, and/or additional components.
- Tuner kits are intended to be dyno-tuned by professional tuners/installers with custom programming.

GENERAL INFORMATION

- You must list Minimum Advertised Pricing (MAP) equal to PRICE as displayed throughout this price guide. MAP = PRICE
- All prices and specifications are subject to change without prior notification. The most recently printed price guide supersedes all previous statements of product specifications and/or pricing.
- Payment is required in advance before product may be shipped ATI accepts payment in the form of credit card (USA only), cashier's check, certified check, wire transfers or money order. Payments made by company check, cashier's check, certified check or money order may cause shipping delays while check clears, unless prior arrangements have been made with ATI.
- All products are shipped F.O.B. Accessible Technologies, Inc., Lenexa, KS. Standard shipping is via Federal Express Ground unless prior arrangements have been made with ATI.
- Some kits may ship in multiple boxes and/or extra large boxes.
- A drop shipment fee will apply to all system, kit and head unit orders not shipped to the purchasing dealer. \$35 for systems and kit orders, \$25 for head unit orders.
- Customer is responsible for all duties, customs, fees and shipping charges required to get product to its destination. Export shipping must be arranged in advance with ATI. All payments on export orders must be made in U.S. funds via wire transfer.
- Drop ships orders may be subject to local sales tax requirements.
- Estimated shipping dates can be obtained from ATI sales or customer service (dates are estimated and not guaranteed).
- All packed orders not shipped within 30 days will be returned to inventory and subject to a 5% restocking fee.
- Inspection of product should occur immediately upon arrival. Any claims of shortages or errors originating at ATI must be made within 5 business days from the date of receipt. Damage to product or packaging must be claimed in accordance with the carrier's policies.
- CARB EO's are applicable at time of purchase and are not retroactive. Only systems with an EO# meet emission requirements for all 50 states and are legal for street use on OEM vehicles only (stock engine, stock exhaust, etc).
- F-Series superchargers may require bellmouth or custom air inlet.
- Model years listed in App guide may not be available at time of print.
- All i-1 systems and all special order systems/kits require non-refundable deposit. See footnotes.

WARRANTY INFORMATION

- 12-month warranty on new, serpentine head unit purchases. Warranty does not cover owner misuse or neglect.
- 36-month head unit only warranty option is available on new, complete systems with P-series & D-1SC head units.
- Limited warranty on cog drive, gear drive or race head unit purchases. Limited means free of manufacturing defects upon receipt.
- 90-day limited warranty on serpentine head unit upgrades.
- 30-day limited warranty on serpentine head unit rebuilds/repairs.
- Exceeding the published supercharger RPM, failure to follow service procedures, or using improper supercharger orientation will void the warranty. The ProCharger warranty applies to original purchaser only and is non-transferrable.
- Failure to use ProCharger specified oil in head units and drives will void ProCharger manufacturer warranty.
- 90-day limited warranty on components purchased separately (excludes electrical and fuel components). 30-day limited warranty on electrical components and fuel components.
- 3-year limited warranty on new air-to-air intercoolers. 1-year limited warranty on new air-to-water intercoolers.
- Wastegates, methanol injection kits, aftermarket intakes, etc may cause damage to supercharger, intercooler, or intake that will not be covered under warranty.

RETURNS

- Returns of new, unused product must be pre-approved by ATI/ProCharger. A 20% restocking fee will apply to part orders and head units, and a 12.5% restocking fee will apply to supercharger systems/kits.
- Supercharger systems/kits returned with the factory seal intact are subject to a restocking fee of 10%. No C.O.D or Freight Collect shipments will be accepted by ATI. Used, damaged, special order or discontinued items may not be returned.
- An RMA (Returned Merchandise Authorization) number must be assigned by ATI for all returns and must be displayed in clear view on the outside of the package and be contained in all correspondence.
- No returns are accepted after 90 days. Returns for electrical and fuel components are limited to 30 days.
- Orders charged via credit card, but canceled prior to leaving ATI, are subject to a 3% cancellation fee.

***NEW* 2024-26 MUSTANG GT (5.0 4V) SYSTEMS AND KITS**

Year	Part Number	Description	Boost Options	HP Gain	Intercooler	Price/MAP
2024-26	1EB214-SCI	Stage 1 Intercooled System with P-1X (shared drive)	12 psi	330+ hp	1200+ hp	\$9,298
2024-26	1EB204-SCI	Stage 1 Intercooled Tuner Kit with P-1X (shared drive)	specify	specify	1200+ hp	\$8,198
2024-26	1EB213-SCI	Stage 2 Intercooled System with P-1X (shared drive)	12 psi	395+ hp	1500+ hp	\$9,498
2024-26	1EB203-SCI	Stage 2 Intercooled Tuner Kit with P-1X (shared drive)	specify	specify	1500+ hp	\$8,398
2024-26	1EB212-SCI	Stage 3 Intercooled System with P-1X (dedicated drive)	12 psi	395+ hp	1500+ hp	\$10,498
2024-26	1EB202-SCI	Stage 3 Intercooled Tuner Kit with P-1X (dedicated drive)	specify	specify	1500+ hp	\$9,398

***NEW* 2024-26 MUSTANG GT PERFORMANCE PACK AND DARKHORSE (5.0 4V) SYSTEMS AND KITS**

Year	Part Number	Description	Boost Options	HP Gain	Intercooler	Price/MAP
2024-26	1EB214-SCI	Stage 1 Intercooled System with P-1X (shared drive)	12 psi	330+ hp	1200+ hp	\$9,398
2024-26	1EB204-SCI	Stage 1 Intercooled Tuner Kit with P-1X (shared drive)	specify	specify	1200+ hp	\$8,298
2024-26	1EB213-SCI	Stage 2 Intercooled System with P-1X (shared drive)	12 psi	395+ hp	1500+ hp	\$9,598
2024-26	1EB203-SCI	Stage 2 Intercooled Tuner Kit with P-1X (shared drive)	specify	specify	1500+ hp	\$8,498
2024-26	1EB212-SCI	Stage 3 Intercooled System with P-1X (dedicated drive)	12 psi	395+ hp	1500+ hp	\$10,598
2024-26	1EB202-SCI	Stage 3 Intercooled Tuner Kit with P-1X (dedicated drive)	specify	specify	1500+ hp	\$9,498

***UPDATED* 2018-23 MUSTANG GT, MACH 1, BULLITT, CALIFORNIA SPECIAL (5.0 4V) SYSTEMS AND KITS**

Year	Part Number	Description	Boost Options	HP Gain	Intercooler	Price/MAP
2018-23	1FW613-SCI	Stage 1 Intercooled System with Factory Airbox and P-1SC-1	8.5 psi	290+ hp	750+ hp	\$7,898
2018-23	1FW603-SCI	Stage 1 Intercooled Tuner Kit with Factory Airbox and P-1SC-1	specify	specify	750+ hp	\$6,698
2018-23	1FW614-SCI	Stage 2 Intercooled System with P-1X (shared drive)	12 psi	320+ hp	1200+ hp	\$8,898
2018-23	1FW604-SCI	Stage 2 Intercooled Tuner Kit with P-1X (shared drive)	specify	specify	1200+ hp	\$7,798
2018-23	1FW612-SCI	Stage 3 Intercooled System with P-1X (dedicated drive)	12 psi	320+ hp	1200+ hp	\$9,798
2018-23	1FW602-SCI	Stage 3 Intercooled Tuner Kit with P-1X (dedicated drive)	specify	specify	1200+ hp	\$8,798

Type	Part Number Suffix	Description	Upgrade From	Requirements	Notes	Price/MAP
FINISH OPTIONS	add "MB" to part #	Machined Billet Finish for Supercharger & Bracket	satin billet	max 9" housing	-	+\$100
	add "B" to part #	Supercharger Finish: Black Billet, max 9.75" housing	satin billet	max 9.75" housing	-	+\$295
	add "P" to part #	Supercharger Finish: Polished Billet, max 9.75" housing	satin billet	max 9.75" housing	-	+\$400
	add "BB" to part #	Supercharger Bracket Finish: Black Billet	satin billet	-	-	+\$225
	add "PB" to part #	Supercharger Bracket Finish: Polished Billet	satin billet	-	-	+\$325
SUPER-CHARGERS	add "BI" to part #	Intercooler Finish: Black	raw	1200+ hp IC only	-	+\$195
	add "P1R" to part #	Supercharger Upgrade: P-1R	P-1X	Tuner Kits only	-	+\$300
	add "D1SC" to part #	Supercharger Upgrade: D-1SC	P-1X	Tuner Kits only	-	+\$50
	add "D1X" to part #	Supercharger Upgrade: D-1X	P-1X	Tuner Kits only	-	+\$200
	add "94" or "C" or "R"	Supercharger Upgrade: F-1A-94, F-1C or F-1R	P-1X	Tuner Kits only	-	+\$950
	add "103" to part #	Supercharger Upgrade: F-1R-103	P-1X	Tuner Kits only	-	+\$2,000
	add "P1X" to part #	Supercharger Upgrade: P-1X	P-1SC-1	-	add'l 15+ hp	+\$250
	add "P1R" to part #	Supercharger Upgrade: P-1R	P-1SC-1	Tuner Kits only	-	+\$600
KIT UPGRADES	add "D1SC" to part #	Supercharger Upgrade: D-1SC	P-1SC-1	Tuner Kits only	-	+\$300
	add "D1X" to part #	Supercharger Upgrade: D-1X	P-1SC-1	Tuner Kits only	-	+\$500
	add "WTY" to part #	3-year / 36,000-mile powertrain warranty (2024-26 only)	-	2024-26 Stage 1 only	-	call
	add "H" to part #	Gears: Helical gearset for noise reduction	straight-cut	P- or D-series only	-	+\$110
	add "BV" to part #	Bullet Blow-off Valve Upgrade (black only)	ProFlow	-	-	+\$125
	add "RVR" or "RVB"	Race Blow-off Valve Upgrade (specify open or closed, alum or steel, red or blk)	ProFlow	Stage II, Race IC only	-	+\$295
	add "10R" to part #	10-rib drive system upgrade	8-rib	Stage 3 Tuner Kit only	-	+\$360
	add "Race" to part #	Intercooler Upgrade: Race air-to-air, 1500+ HP	1,200+ HP	2018-23 Tuner Kits only	Stage 2 & 3 only	+\$435
	add "INJ" to part #	55 lb/hr Fuel Injectors	-	Tuner Kits only	-	+\$320
	add "INJ" to part #	95 lb/hr Fuel Injectors	-	Tuner Kits only	-	+\$750
	add "FPB" to part #	Fuel Pump Booster	-	Tuner Kits only	-	+\$470
	add "CP" to part #	8.00" Crank Pulley Upgrade (requires aftermarket balancer)	-	2018-23 Tuner Kits only	-	+\$120
	add "OC" to part #	Oil Cooler Relocation Kit (2024-26 Darkhorse and GT Performance Pack only)	-	-	-	+\$350
add "CS" to part #	Coyote Crank Support, satin finish	-	Stage 3 only	-	+\$675	
add "BC" or "PC" to part #	Black or Polished finish for Crank Support	satin	Stage 3 only	-	+\$275	

OPTIONS FOR THIS PAGE

SPECIFICATIONS

***NEW* 2024-26 MUSTANG GT (5.0 4V) SYSTEMS AND KITS**

Year	Part Number	OEM hp Rating	HP Gain	Tube Diam	Intercooler Mount	Drive System	Blow-off System	Fuel System Upgrade	Fuel Inj. Supplied	Computer/Ignition Modifications	Supercharger Warranty (in months)	CARB E.O.	Foot Notes
2024-26	1EB214-SCI	480	330+ hp	3-3.5"	V	stk 6-rib	ProFlow	not required	55 lb/hr	programmer supplied	12, 36 opt. (\$99)	-	A: 1, 2, 7, 9, 13
2024-26	1EB204-SCI	480	specif	3-3.5"	V	stk 6-rib	ProFlow	not required	No	not supplied	12	-	A: 1, 2, 7, 9, 13
2024-26	1EB213-SCI	480	395+ hp	3-3.5"	V	stk 6-rib	ProFlow	not required	55 lb/hr	programmer supplied	12, 36 opt. (\$99)	-	A: 1, 2, 7, 9, 11, 13, 15
2024-26	1EB203-SCI	480	specify	3-3.5"	V	stk 6-rib	ProFlow	not required	No	not supplied	12	-	A: 1, 2, 7, 9, 13, 15
2024-26	1EB212-SCI	480	395+ hp	3-3.5"	V	add'l 8-rib	ProFlow	not required	55 lb/hr	programmer supplied	12, 36 opt. (\$99)	-	A: 1, 2, 7, 9, 11, 13, 15
2024-26	1EB202-SCI	480	specify	3-3.5"	V	add'l 8-rib	ProFlow	not required	No	not supplied	12	-	A: 1, 2, 7, 9, 13, 15

***NEW* 2024-26 MUSTANG GT PERFORMANCE PACK AND DARKHORSE (5.0 4V) SYSTEMS AND KITS**

Year	Part Number	OEM hp Rating	HP Gain	Tube Diam	Intercooler Mount	Drive System	Blow-off System	Fuel System Upgrade	Fuel Inj. Supplied	Computer/Ignition Modifications	Supercharger Warranty (in months)	CARB E.O.	Foot Notes
2024-26	1EB214-SCI	480/500	330+ hp	3-3.5"	V	stk 6-rib	ProFlow	not required	55 lb/hr	programmer supplied	12, 36 opt. (\$99)	-	A: 1, 2, 7, 9, 13, 14
2024-26	1EB204-SCI	480/500	specify	3-3.5"	V	stk 6-rib	ProFlow	not required	No	not supplied	12	-	A: 1, 2, 7, 9, 13, 14
2024-26	1EB213-SCI	480/500	395+ hp	3-3.5"	V	stk 6-rib	ProFlow	not required	55 lb/hr	programmer supplied	12, 36 opt. (\$99)	-	A: 1, 2, 7, 9, 11, 13, 14, 15
2024-26	1EB203-SCI	480/500	specify	3-3.5"	V	stk 6-rib	ProFlow	not required	No	not supplied	12	-	A: 1, 2, 7, 9, 13, 14, 15
2024-26	1EB212-SCI	480/500	395+ hp	3-3.5"	V	add'l 8-rib	ProFlow	not required	55 lb/hr	programmer supplied	12, 36 opt. (\$99)	-	A: 1, 2, 7, 9, 11, 13, 14, 15
2024-26	1EB202-SCI	480/500	specify	3-3.5"	V	add'l 8-rib	ProFlow	not required	No	not supplied	12	-	A: 1, 2, 7, 9, 13, 14, 15

***UPDATED* 2018-23 MUSTANG GT, MACH 1, BULLITT, CALIFORNIA SPECIAL (5.0 4V) SYSTEMS AND KITS**

Year	Part Number	OEM hp Rating	HP Gain	Tube Diam	Intercooler Mount	Drive System	Blow-off System	Fuel System Upgrade	Fuel Inj. Supplied	Computer/Ignition Modifications	Supercharger Warranty (in months)	CARB E.O.	Foot Notes
2018-23	1FW613-SCI	460/480	290+ hp	3-3.5"	V	stk 6-rib	ProFlow	pump voltage booster	52 lb/hr	programmer supplied	12, 36 opt. (\$99)	D-365-38 (18-23)	A: 1, 4, 6, 7, 9, 12
2018-23	1FW603-SCI	460/480	specify	3-3.5"	V	stk 6-rib	ProFlow	not required	No	not supplied	12	-	A: 1, 4, 6, 7, 9, 12
2018-23	1FW614-SCI	460/480	320+ hp	3-3.5"	V	stk 6-rib	ProFlow	not required	55 lb/hr	programmer supplied	12, 36 opt. (\$99)	-	A: 1, 2, 4, 7, 9, 12
2018-23	1FW604-SCI	460/480	specify	3-3.5"	V	stk 6-rib	ProFlow	not required	No	not supplied	12	-	A: 1, 4, 7, 9, 12, 15
2018-23	1FW612-SCI	460/480	320+ hp	3-3.5"	V	add'l 8-rib	ProFlow	not required	55 lb/hr	programmer supplied	12, 36 opt. (\$99)	-	A: 1, 2, 4, 7, 8, 11, 12
2018-23	1FW602-SCI	460/480	specify	3-3.5"	V	add'l 8-rib	ProFlow	not required	No	not supplied	12	-	A: 1, 4, 7, 8, 10, 11, 12, 15

FORD AUTOMOTIVE FOOTNOTES (specific to above applications):

- A1) Model year must be specified
- A2) Due to variability among OEM computers, the prevalence of custom modifications, and age/miles/condition of vehicles, dyno tuning may be required
- A4) California Special models may require trimming
- A5) Specify factory or aftermarket balancer (ATI P/N 918047 or Innovators West #817)
- A6) An enclosed airbox is provided as part of the kit for Mach 1 and Bullitt
- A7) Specify manual or automatic transmission
- A8) Factory sway bar only
- A9) Minor timing cover modifications may be required for all shared drive kits
- A10) 10-rib or Crank Support requires removal of factory sway bar
- A11) Crank Support requires aftermarket balancer
- A12) Mach 1 hood liner may require trimming
- A13) Specify GT, GT Performance Pack, or Darkhorse
- A14) Darkhorse and Performance Pack kits include block-off for oil cooler; relocation kit available as upgrade
- A15) 1500 hp intercooler requires minor trimming



***UPDATED* 2015-20 GT350 AND GT350R (5.2 4V) SYSTEMS AND KITS**

Year	Part Number	Description	Boost Options	HP Gain	Intercooler	Price/MAP
2015-20	1FW312-SCI	Stage 2 Intercooled System with P-1X (shared drive)	6 psi	175+ hp	1100+ hp	\$8,998
2015-20	1FW302-SCI	Stage 2 Intercooled Tuner Kit with P-1X (shared drive)	specify	specify	1100+ hp	\$7,798
2015-20	1FW314-SCI	Stage 3 Intercooled System with P-1X (dedicated drive)	9 psi	350 + hp	1100+ hp	\$10,298
2015-20	1FW304-SCI	Stage 3 Intercooled Tuner Kit with P-1X (dedicated drive)	specify	specify	1100+ hp	\$9,298

***UPDATED* 2015-17 MUSTANG GT (5.0 4V) SYSTEMS AND KITS**

Year	Part Number	Description	Boost Options	HP Gain	Intercooler	Price/MAP
2015-17	1FW411-SCI	Stage 1 Intercooled System with Factory Airbox and P-1SC-1	9 psi	285+ hp	750+ hp	\$7,898
2015-17	1FW401-SCI	Stage 1 Intercooled Tuner Kit with Factory Airbox and P-1SC-1	specify	specify	750+ hp	\$6,698
2015-17	1FW214-SCI	Stage 2 Intercooled System with P-1X (shared drive)	10 psi	305+ hp	1200+ hp	\$8,898
2015-17	1FW204-SCI	Stage 2 Intercooled Tuner Kit with P-1X (shared drive)	specify	specify	1200+ hp	\$7,798
2015-17	1FW212-SCI	Stage 3 Intercooled System with P-1X (dedicated belt drive)	10 psi	305+ hp	1200+ hp	\$9,798
2015-17	1FW202-SCI	Stage 3 Intercooled Tuner Kit with P-1X (dedicated belt drive)	specify	specify	1200+ hp	\$8,798

2015-17 MUSTANG V6 (3.7 4V) SYSTEMS AND KITS

Year	Part Number	Description	Boost Options	HP Gain	Intercooler	Price/MAP
2015-17	1FT412-SCI	Intercooled Supercharger System with P-1SC-1	8 psi	150+ hp	750+ hp	\$7,998
2015-17	1FT402-SCI	Intercooled Supercharger Tuner Kit with P-1SC-1	specify	specify	750+ hp	\$7,248

Type	Part Number Suffix	Description	Upgrade From	Requirements	Notes	Price/MAP
FINISH OPTIONS	add "MB" to part #	Machined Billet Finish for Supercharger & Bracket	satin billet	max 9" housing	-	+\$100
	add "P" to part #	Supercharger Finish: Polished, max 9.75" housing	satin	max 9.75" housing	-	+\$400
	add "P" to part #	Supercharger Finish: Polished, max 9.75" housing	satin	max 9.75" housing	-	+\$400
	add "BB" to part #	Supercharger Bracket Finish: Black	satin	-	-	+\$225
	add "PB" to part #	Supercharger Bracket Finish: Polished	satin	-	-	+\$325
	add "BI" to part #	Intercooler Finish: Black	raw	1200+ HP IC Only	-	+\$195
SUPER-CHARGERS	add "P1R" to part #	Supercharger Upgrade: P-1R	P-1X	Tuner Kits only	-	+\$300
	add "D1SC" to part #	Supercharger Upgrade: D-1SC	P-1X	Tuner Kits only	-	+\$50
	add "D1X" to part #	Supercharger Upgrade: D-1X	P-1X	Tuner Kits only	-	+\$200
	add "D" or "1" or "A"	Supercharger Upgrade: F-1D, F-1, F-1A	P-1X	Tuner Kits only	-	+\$600
	add "94" or "C" or "R"	Supercharger Upgrade: F-1A-94, F-1C or F-1R	P-1X	Tuner Kits only	-	+\$950
	add "103" to part #	Supercharger Upgrade: F-1R-103	P-1X	Tuner Kits only	-	+\$2,000
	add "P1X" to part #	Supercharger Upgrade: P-1X	P-1SC-1	-	add'l 15+ hp	+\$250
	add "P1R" to part #	Supercharger Upgrade: P-1R	P-1SC-1	Tuner Kits only	-	+\$600
	add "D1SC" to part #	Supercharger Upgrade: D-1SC	P-1SC-1	Tuner Kits only	-	+\$300
	add "D1X" to part #	Supercharger Upgrade: D-1X	P-1SC-1	Tuner Kits only	-	+\$500
KIT UPGRADES	add "H" to part #	Gears: Helical gearset for noise reduction	straight-cut	-	-	+\$110
	add "BV" to part #	Bullet Blow-off Valve Upgrade (black only)	ProFlow	-	-	+\$125
	add "RVR" or "RVB"	Race Blow-off Valve Upgrade (specify open or closed, alum or steel, red or blk)	ProFlow	Stage 2, 3 only	-	+\$295
	add "Race" to part #	Intercooler Upgrade: Race air-to-air, 1200+ HP	750+ HP	V6 Tuner Kit only	-	+\$435
	add "INJ" to part #	95 lb/hr Fuel Injectors	-	Tuner Kits only	-	+\$750
	add "INJ" to part #	55 lb/hr Fuel Injectors	-	Tuner Kits only	-	+\$320
	add "FPB" to part #	Fuel Pump Booster	-	Tuner Kits only	-	+\$470
	add "10R" to part #	10-rib drive system upgrade	8-rib	GT Stage 3 Tuner Kits only	-	+\$360
	add "CS" to part #	Coyote Crank Support, satin finish	-	Stage 3 only	-	+\$675
	add "BC" or "PC" to part #	Black or Polished finish for Crank Support	satin	Stage 3 only	-	+\$275
	add "CP" to part #	7.00" Crank Pulley Upgrade	6.25" standard	GT350 only	-	+\$120
add "CP" to part #	8.00" Crank Pulley Upgrade (requires aftermarket balancer)	6.25" standard	GT350 only	-	+\$120	
V6 ONLY	add "AIR" to part #	Air Inlet Upgrade: Stage II Package	HO std inlet	-	-	+\$45

FOR COYOTE & GODZILLA ENGINE SWAP KITS, SEE PAGE 24

SPECIFICATIONS

2015-20 GT350 AND GT350R (5.2 4V) SPECIFICATIONS

Year	Part Number	OEM hp Rating	HP Gain	Tube Diam	Intercooler Mount	Drive System	Blow-off System	Fuel System Upgrade	Fuel Inj. Supplied	Computer/Ignition Modifications	Supercharger Warranty (in months)	CARB E.O.	Foot Notes
2015-20	1FW312-SCI	526	175+hp	3"	V	stk 6-rib	ProFlow	not required	95 lb/hr	programmer supplied	12, 36 opt. (\$99)	-	AA: 1, 2, 5, 8, 11
2015-20	1FW302-SCI	526	specify	3"	V	stk 6-rib	ProFlow	not supplied	No	not supplied	12	-	AA: 1, 4, 5, 8, 11
2015-20	1FW314-SCI	526	350+hp	3"	V	add'l 8-rib	ProFlow	not supplied	95 lb/hr	programmer supplied	12, 36 opt. (\$99)	-	AA: 1, 2, 8, 9, 10, 12
2015-20	1FW304-SCI	526	specify	3"	V	add'l 8-rib	ProFlow	not supplied	No	not supplied	12	-	AA: 1, 8, 9, 10, 12

2015-17 MUSTANG GT (5.0 4V) SPECIFICATIONS

Year	Part Number	OEM hp Rating	HP Gain	Tube Diam	Intercooler Mount	Drive System	Blow-off System	Fuel System Upgrade	Fuel Inj. Supplied	Computer/Ignition Modifications	Supercharger Warranty (in months)	CARB E.O.	Foot Notes
2015-17	1FW411-SCI	435	285+ hp	3"	V	stk 6-rib	ProFlow	pump voltage booster	52 lb/hr	programmer supplied	12, 36 opt. (\$99)	D-365-16	AA: 1, 4, 5, 8
2015-17	1FW401-SCI	435	specify	3"	V	stk 6-rib	ProFlow	not supplied	No	not supplied	12	-	AA: 1, 4, 5, 8
2015-17	1FW214-SCI	435	305+ hp	3"	V	stk 6-rib	ProFlow	not required	55 lb/hr	programmer supplied	12, 36 opt. (\$99)	-	AA: 1, 2, 4, 5, 8, 11
2015-17	1FW204-SCI	435	specify	3"	V	stk 6-rib	ProFlow	not supplied	No	not supplied	12	-	AA: 1, 4, 5, 8, 11
2015-17	1FW212-SCI	435	305+ hp	3"	V	add'l 8-rib	ProFlow	not required	55 lb/hr	programmer supplied	12, 36 opt. (\$99)	-	AA: 1, 2, 4, 5, 8, 10, 12
2015-17	1FW202-SCI	435	specify	3"	V	add'l 8-rib	ProFlow	not supplied	No	not supplied	12	-	AA: 1, 2, 4, 5, 8, 10, 12

2015-17 MUSTANG V6 (3.7V) SPECIFICATIONS

Year	Part Number	OEM hp Rating	HP Gain	Tube Diam	Intercooler Mount	Drive System	Blow-off System	Fuel System Upgrade	Fuel Inj. Supplied	Computer/Ignition Modifications	Supercharger Warranty (in months)	CARB E.O.	Foot Notes
2015-17	1FT412-SCI	300	150+ hp	3"	V	add'l 6-rib	ProFlow	not required	50 lb/hr	programmer supplied	12, 36 opt. (\$99)	-	AA: 1, 2, 7, 8
2015-17	1FT402-SCI	300	specify	3"	V	add'l 6-rib	ProFlow	not supplied	No	not supplied	12	-	AA: 1, 7, 8

FORD AUTOMOTIVE FOOTNOTES (specific to above applications):

- AA1) Model year must be specified.
- AA2) Due to variability among OEM computers, the prevalence of custom modifications and age/miles/condition of vehicles, dyno tuning may be required; Stock vehicles with cat-back exhaust systems may require custom tuning
- AA4) California Special models may require trimming.
- AA5) Specify factory or aftermarket balancer. (ATI P/N 918047 or Innovator's West P/N 817)
- AA7) Upgraded driveshaft recommended
- AA8) Specify manual or automatic transmission
- AA9) Aftermarket balancer is included in Stage II GT350 Systems and Kits
- AA10) Factory sway bar only
- AA11) Minor timing cover modifications may be required.
- AA12) Crank Support and 10-rib requires removal of factory sway bar



2011-14 MUSTANG GT (5.0 4V) SYSTEMS AND KITS

Year	Part Number	Description	Boost Options	HP Gain	Intercooler	Price/MAP
2011-14	1FR211-SCI	High Output Intercooled System with Factory Airbox and P-1SC-1 (shared drive)	7.5 psi	50%+	750+ hp	\$7,998
2011-14	1FR201-SCI	High Output Intercooled Tuner Kit with Factory Airbox and P-1SC-1 (shared drive)	specify	specify	750+ hp	\$6,998
2011-12	1FR214-SCI	High Output Intercooled System with P-1SC-1	7.5 psi	50%+	3 core	\$8,248
2011-12	1FR204-SCI	High Output Intercooled Tuner Kit with P-1SC-1	specify	specify	3 core	\$7,348
2011-14	1FR212-SCI	Stage II Intercooled System with P-1SC-1	8 psi	55%+	Stage II	\$8,998
2011-14	1FR202-SCI	Stage II Intercooled Tuner Kit with P-1SC-1	specify	specify	Stage II	\$7,898
2011-14	1FR200-F1	Intercooled Cog Race Kit with F-1D, F-1 or F-1A	specify	specify	Race	\$9,478
2011-14	1FR200-SCI-94	Intercooled Cog Race Kit with F-1A-94, F-1C or F-1R	specify	specify	Race	\$9,798

2012-13 BOSS 302 MUSTANG (5.0 4V) SYSTEMS AND KITS

Year	Part Number	Description	Boost Options	HP Gain	Intercooler	Price/MAP
2012-13	1FR312-SCI	Stage II Intercooled System with P-1SC-1	8.5 psi	50%+	Stage II	\$9,088
2012-13	1FR302-SCI	Stage II Intercooled Tuner Kit with P-1SC-1	specify	specify	Stage II	\$8,178
2012-13	1FR300-F1	Intercooled Cog Race Kit with F-1D, F-1 or F-1A	specify	specify	Race	\$9,548
2012-13	1FR300-SCI-94	Intercooled Cog Race Kit with F-1A-94, F-1C or F-1R	specify	specify	Race	\$9,798

2011-14 MUSTANG V6 (3.7 4V) SYSTEMS AND KITS

Year	Part Number	Description	Boost Options	HP Gain	Intercooler	Price/MAP
2011-14	1FT212-SCI	Intercooled Supercharger System with P-1SC-1	8 psi	50-60%	3 core	\$8,078
2011-14	1FT202-SCI	Intercooled Supercharger Tuner Kit with P-1SC-1	specify	specify	3 core	\$7,248

Applications	Part Number Suffix	Description	Upgrade From	Requirements	Notes	Price/MAP
ALL	add "B" to part #	Supercharger Finish: Black, max 9.75" housing	satin	max 9.75" housing	-	+\$295
	add "P" to part #	Supercharger Finish: Polished, max 9.75" housing	satin	max 9.75" housing	-	+\$400
	add "BB" to part #	Supercharger Bracket Finish: Black	satin	-	-	+\$225
	add "PB" to part #	Supercharger Bracket Finish: Polished	satin	-	-	+\$325
	add "H" to part #	Gears: Helical gearset for noise reduction	straight-cut	P- or D-series only	-	+\$110
GT & BOSS 302 ONLY	add "D1SC" to part #	Supercharger Upgrade: D-1SC	P-1SC-1	Tuner Kits only	-	+\$300
	add "P1X" to part #	Supercharger Upgrade: P-1X	P-1SC-1	-	add'l 10-15+ hp	+\$250
	add "P1R" to part #	Supercharger Upgrade: P-1R	P-1SC-1	-	-	+\$600
	add "D1X" to part #	Supercharger Upgrade: D-1X	P-1SC-1	Tuner Kit only	-	+\$500
	add "D" or "1" or "A"	Supercharger Upgrade: F-1D, F-1, F-1A	P-1SC-1	Tuner Kit only	-	+\$900
	add ".94" or "C" or "R"	Supercharger Upgrade: F-1A-94, F-1C or F-1R	P-1SC-1	Stage II Tuner Kit only	-	+\$1,250
	add "RVR" or "RVB"	Race Blow-off Valve Upgrade (specify open or closed, alum or steel, red or blk)	ProFlow	-	-	+\$295
	add "10R" to part #	10-rib drive system upgrade	8-rib	Stage II Tuner Kit only	-	+\$360
	add "CS" to part #	Coyote Crank Support, satin finish	-	-	-	+\$675
	add "BC" or "PC" to part #	Black or Polished finish for Crank Support	satin	-	-	+\$275
GT ONLY	add "AIR" to part #	Air Inlet Upgrade: Stage II Package	HO std inlet	-	-	+\$45
	add "AIR" to part #	Air Inlet Upgrade: Cold Air Package	std inlet	-	-	+\$130
	i-1 ONLY	SEE PAGE 88 FOR i-1 OPTIONS				

2011-14 MUSTANG GT / 2012-13 BOSS 302 MUSTANG (5.0 4V) i-1 PROGRAMMABLE RATIO SYSTEMS

Year	Part Number	Description	Boost Options	HP Gain	Intercooler	Price/MAP
2011-14 GT	1FR215-SCI	Stage II Intercooled System with i-1	7.5 psi	55%+	Stage II	\$13,498
BOSS 302	1FR315-SCI	Stage II Intercooled System with i-1	8.5 psi	55%+	Stage II	\$13,698

FOR COYOTE & GODZILLA ENGINE SWAP KITS, SEE PAGE 24

SPECIFICATIONS

2011-14 MUSTANG GT (5.0 4V) SPECIFICATIONS

Year	Part Number	OEM hp Rating	HP Gain	Tube Diam	IC Mount	Drive System	Blow-off System	Fuel System Upgrade	Fuel Inj. Supplied	Computer/Ignition Modifications	Supercharger Warranty (in months)	CARB E.O.	Foot Notes
2011-14	1FR211-SCI	412	50%+	3"	V	stk 6-rib	ProFlow	not required	52 lb/hr	programmer supplied	12, 36 opt. (\$99)	D-365-34	B: 1, 2, 5, 6, 10, 12
2011-14	1FR201-SCI	412	specify	3"	V	stk 6-rib	ProFlow	not supplied	No	not supplied	12	-	B: 1, 5, 6, 10
2011-12	1FR214-SCI	412	50%+	3"	V	add'l 8-rib	ProFlow	not required	52 lb/hr	programmer supplied	12, 36 opt. (\$99)	-	B: 1, 2, 5, 6, 8, 10, 11, 12
2011-12	1FR204-SCI	412	specify	3"	V	add'l 8-rib	ProFlow	not supplied	No	not supplied	12	-	B: 1, 5, 6, 8, 9, 10, 11
2011-14	1FR212-SCI	412	55%+	3"	V	add'l 8-rib	ProFlow	not required	52 lb/hr	programmer supplied	12, 36 opt. (\$99)	-	B: 1, 2, 5, 7, 8, 10, 11, 12
2011-14	1FR202-SCI	412	specify	3"	V	add'l 8-rib	ProFlow	not supplied	No	not supplied	12	-	B: 1, 5, 7, 8, 9, 10, 11
2011-14	1FR200-F1	-	specify	3"	V	cog	Race	not supplied	No	not supplied	Limited	-	B: 1, 3, 5, 8, 9, 10
2011-14	1FR200-SCI-94	-	specify	3"	V	cog	Race	not supplied	No	not supplied	Limited	-	B: 1, 3, 5, 8, 9, 10

2012-13 BOSS 302 MUSTANG SPECIFICATIONS

Year	Part Number	OEM hp Rating	HP Gain	Tube Diam	tercool Mount	Drive System	Blow-off System	Fuel System Upgrade	Fuel Inj. Supplied	Computer/Ignition Modifications	Supercharger Warranty (in months)	CARB E.O.	Foot Notes
2012-13	1FR312-SCI	444	50%+	3"	V	add'l 8-rib	ProFlow	pump voltage booster	52 lb/hr	programmer supplied	12, 36 opt. (\$99)	-	B: 1, 2, 8, 12, 15
2012-13	1FR302-SCI	444	specify	3"	V	add'l 8-rib	ProFlow	not supplied	No	not supplied	12	-	B: 1, 8, 15
2012-13	1FR300-F1	-	specify	3"	V	cog	Race	not supplied	No	not supplied	Limited	-	B: 1, 3, 7
2012-13	1FR300-SCI-94	-	specify	3"	V	cog	Race	not supplied	No	not supplied	Limited	-	B: 1, 3, 7

2011-14 MUSTANG V6 (3.7 4V) SPECIFICATIONS

Year	Part Number	OEM hp Rating	HP Gain	Tube Diam	IC Mount	Drive System	Blow-off System	Fuel System Upgrade	Fuel Inj. Supplied	Computer/Ignition Modifications	Supercharger Warranty (in months)	CARB E.O.	Foot Notes
2011-14	1FT212-SCI	305	50-60%	3"	V	add'l 6-rib	ProFlow	not required	50 lb/hr	programmer supplied	12, 36 opt. (\$99)	-	B: 1, 2, 12, 13
2011-14	1FT202-SCI	305	specify	3"	V	add'l 6-rib	ProFlow	not supplied	No	not supplied	12	-	B: 1, 13

2011-14 MUSTANG GT / 2012-13 BOSS 302 MUSTANG (5.0 4V) i-1 PROGRAMMABLE RATIO SPECIFICATIONS

Year	Part Number	OEM hp Rating	HP Gain	Tube Diam	IC Mount	Drive System	Blow-off System	Fuel System Upgrade	Fuel Inj. Supplied	Computer/Ignition Modifications	Supercharger Warranty (in months)	CARB E.O.	Foot Notes
2011-14	1FR215-SCI	412	55%+	3"	V	add'l 8-rib	ProFlow	not required	52 lb/hr	programmer supplied	12, 36 opt. (\$599)	-	B: 1, 2, 8, 10, 12, 14, 16
2012-13	1FR315-SCI	444	55%+	3"	V	add'l 8-rib	ProFlow	pump voltage booster	52 lb/hr	programmer supplied	12, 36 opt. (\$599)	-	B: 1, 2, 8, 12, 14, 16

FORD AUTOMOTIVE FOOTNOTES (specific to above applications):

- B1) Model
- B2) Due to variability among OEM computers, the prevalence of custom modifications and age/miles/condition of vehicles, dyno tuning may be required; Stock vehicles with cat-back exhaust systems may require custom tuning
- B3) Modified engines only
- B5) California Special models may require trimming
- B6) Fog lights may need to be removed in 2013-14 Mustang GT vehicles with HO Systems and Kits
- B7) 2011-12 Stage II Systems require trimming of plastic bumper cover (behind bumper, not visible)
- B8) Specify factory or aftermarket balancer
- B9) Specify ATI Balancer #918047 or Innovators West #817 required for 10-rib upgrade and Cog Kits (not included - specify hardened hub)
- B10) Specify if vehicle has optional Ford track-pack package
- B11) Stage II air inlet does not fit in 2011-14 Mustang GT vehicles equipped with upper strut bar
- B12) ECM code required
- B13) Upgraded driveshaft recommended
- B14) Two-part shipment, additional shipping charges may apply
- B15) 2012 Stage II Systems require trimming of plastic bumper cover (behind bumper, not visible)
- B16) Special order kit: order form and non-refundable deposit required at time of order—may require additional lead time for processing



2005-10 MUSTANG GT (4.6 3V) SYSTEMS AND KITS

Year	Part Number	Description	Boost Options	HP Gain	Intercooler	Price/MAP
2005-09	1FP311-SCI	Intercooled Supercharger System with P-1SC-1 (shared drive)	10 psi	70-75%	3 core	\$7,998
2005-09	1FP301-SCI	Intercooled Supercharger Tuner Kit with P-1SC-1 (shared drive)	specify	specify	3 core	\$6,998
2005-10	1FP214-SCI	High Output Intercooled System with P-1SC-1	10 psi	70-75%	3 core	\$8,148
2005-10	1FP204-SCI	High Output Intercooled Tuner Kit with P-1SC-1	specify	specify	3 core	\$6,998
2005-09	1FP211-SCI	Stage II Intercooled System with P-1SC-1	10 psi	70-75%	3 core	\$8,578
2005-09	1FP202-SCI	Stage II Intercooled Tuner Kit with P-1SC-1	specify	specify	3 core	\$7,588
2005-09	1FP213-F1	Intercooled Serp Race Kit (12-rib) with F-1A	specify	specify	800+ hp	\$8,948

2005-10 MUSTANG V6 (4.0) SYSTEMS AND KITS

Year	Part Number	Description	Boost Options	HP Gain	Intercooler	Price/MAP
2005-10	1FQ212-SCI	Stage II Intercooled System with P-1SC	8 psi	55-60%	2 core	\$7,148
2005-10	1FQ202-SCI	Intercooled Tuner Kit with P-1SC	specify	specify	2 core	\$6,248

Applications	Part Number Suffix	Description	Upgrade From	Requirements	Notes	Price/MAP
ALL	add "-B" to part #	Supercharger Finish: Black, max 9.75" housing	satn	max 9.75" housing	-	+\$295
	add "-P" to part #	Supercharger Finish: Polished, max 9.75" housing	satn	max 9.75" housing	-	+\$400
	add "-BB" to part #	Supercharger Bracket Finish: Black	satn	-	-	+\$225
	add "-PB" to part #	Supercharger Bracket Finish: Polished	satn	-	-	+\$325
	add "-H" to part #	Gears: Helical gearset for noise reduction	straight-cut	P- or D-series only	-	+\$110
GT ONLY	add "-P" to part #	Throttle Body Tube Inlet Finish: Polished	raw	-	-	+\$200
	add "-P1X" to part #	Supercharger Upgrade: P-1X	P-1SC-1	-	add1 10-15+ hp	+\$250
	add "-D1SC" to part #	Supercharger Upgrade: D-1SC	P-1SC-1	Tuner Kit only	-	+\$300
	add "-D1X" to part #	Supercharger Upgrade: D-1X	P-1SC-1	Tuner Kit only	-	+\$500
	add "-D" or "-1" or "-A"	Supercharger Upgrade: F-1D, F-1, F-1A	P-1SC-1	Stage II Tuner Kits only	-	+\$900
	add "-94" or "-C" or "-R"	Supercharger Upgrade: F-1A-94, F-1C or F-1R	P-1SC-1	Stage II Tuner Kits only	-	+\$1,250
	add "-94" or "-C" or "-R"	Supercharger Upgrade: F-1A-94, F-1C or F-1R	F-1A	Serp Race Kits only	-	+\$350
	add "-RVR" or "-RVB"	Race Blow-off Valve Upgrade (specify open or closed, alum or steel, red or blk)	ProFlow	-	-	+\$295
add "-800" to part #	Intercooler Upgrade: 800+ HP air-to-air, 900 HP max	3-core	Stage II only	3" tubing	+\$435	
V6 ONLY	add "-C" to part #	Supercharger Upgrade: P-1SC-1	P-1SC	-	-	+\$220
	add "-D1SC" to part #	Supercharger Upgrade: D-1SC	P-1SC	-	-	+\$525
	add "-3C" to part #	Intercooler Upgrade: 3-core air-to-air	2-core	-	3" tubing	+\$435

FOR COYOTE & GODZILLA ENGINE SWAP KITS, SEE PAGE 24

SPECIFICATIONS

2005-10 MUSTANG GT (4.6 3V) SPECIFICATIONS

Year	Part Number	OEM hp Rating	HP Gain	Tube Diam	Intercooler Mount	Drive System	Blow-off System	Fuel System Upgrade	Fuel Inj. Supplied	Computer/Ignition Modifications	Supercharger Warranty (in months)	CARB E.O.	Foot Notes
2005-09	1FP311-SCI	300	70-75%	2.5-3"	V	stk 6-rib	ProFlow	in-tank pump	39.5 lb/hr	programmer supplied	12, 36 opt. (\$99)	D-365-34	D: 1, 2
2005-09	1FP301-SCI	300	specify	2.5-3"	V	stk 6-rib	ProFlow	not supplied	No	not supplied	12	-	D: 1
2005-10	1FP214-SCI	300	70-75%	2.5-3"	V	add1 8-rib	ProFlow	in-tank pump	39.5 lb/hr	programmer supplied	12, 36 opt. (\$99)	-	D: 1, 2, 7
2005-10	1FP204-SCI	300	specify	2.5-3"	V	add1 8-rib	ProFlow	not supplied	No	not supplied	12	-	D: 1, 7
2005-09	1FP211-SCI	300	70-75%	3"	V	add1 8-rib	ProFlow	in-tank pump	39.5 lb/hr	programmer supplied	12, 36 opt. (\$99)	-	D: 1, 2, 6
2005-09	1FP202-SCI	300	specify	3"	V	add1 8-rib	ProFlow	not supplied	No	not supplied	12	-	D: 1, 6
2005-09	1FP213-F1	-	specify	3"	V	add1 12-rib	Race	not supplied	No	not supplied	12	-	D: 1, 3, 4, 5, 6

2005-10 MUSTANG V6 (4.0) SPECIFICATIONS

Year	Part Number	OEM hp Rating	HP Gain	Tube Diam	Intercooler Mount	Drive System	Blow-off System	Fuel System Upgrade	Fuel Inj. Supplied	Computer/Ignition Modifications	Supercharger Warranty (in months)	CARB E.O.	Foot Notes
2005-10	1FQ212-SCI	220	55-60%	3"	V	stk 6-rib	ProFlow	not required	39.5 lb/hr	programmer supplied	12, 36 opt. (\$99)	-	D: 1, 2, 8, 9
2005-10	1FQ202-SCI	220	specify	3"	V	stk 6-rib	ProFlow	not supplied	No	not supplied	12	-	D: 1, 9

FORD AUTOMOTIVE FOOTNOTES (specific to above applications):

- D1) Model year must be specified
 D2) Due to variability among OEM computers, the prevalence of custom modifications and age/miles/condition of vehicles, dyno tuning may be required; Stock vehicles with cat-back exhaust systems may require custom tuning
 D3) Modified engines only
 D4) Inner fender modification required
 D5) Requires use of ATI Performance Products aftermarket balancer, part #918039 (not included - specify hardened hub)
 D6) 800+ hp intercooler may require trimming of plastic bumper cover (behind bumper, not visible)
 D7) Fog lights may need to be removed on 2010 Mustang GT's
 D8) ECM code required
 D9) Special order kit: order form and non-refundable deposit required at time of order—may require additional lead time for processing



1999-04 MUSTANG GT AND 2001 BULLITT (4.6 2V) SYSTEMS AND KITS

Year	Part Number	Description	Boost Options	HP Gain	Intercooler	Price/MAP
1999-04	1FE212-SCI	High Output Intercooled System with P-1SC	8 psi	55-60%	2 core	\$6,998
1999-04	1FE202-SCI	High Output Intercooled Tuner Kit with P-1SC	specify	specify	2 core	\$5,998
1999-04	1FE211-SCI	Stage II Intercooled System with P-1SC	8 psi	60-65%	3 core	\$7,433
1999-04	1FE201-SCI	Stage II Intercooled Tuner Kit with P-1SC	specify	specify	3 core	\$6,433
2001 BULLITT	add "-B" to part # above	Same as 1999-04 Mustang GT	see above	see above	see above	see above

2003-04 MUSTANG MACH 1 (4.6 4V) SYSTEMS AND KITS

Year	Part Number	Description	Boost Options	HP Gain	Intercooler	Price/MAP
2003-04	1FL212-SCI	Stage II Intercooled System with P-1SC	8 psi	60-65%	3 core	\$8,378
2003-04	1FL202-SCI	Stage II Intercooled Tuner Kit with P-1SC	specify	specify	3 core	\$7,298

1996-98 MUSTANG GT (4.6 2V) SYSTEMS AND KITS

Year	Part Number	Description	Boost Options	HP Gain	Intercooler	Price/MAP
1996-98	1FD211-10I	High Output Intercooled System with P-1SC	8, 10 psi	55-70%	2 core	\$6,348
1996-98	1FD201-SCI	High Output Intercooled Tuner Kit with P-1SC	specify	specify	2 core	\$5,998
1996-98	1FD212-SCI	Stage II Intercooled System with P-1SC	8, 10, 12 psi	60-80%	3 core	\$6,783
1996-98	1FD202-SCI	Stage II Intercooled Tuner Kit with P-1SC	specify	specify	3 core	\$6,433

1994-04 MUSTANG V6 (3.8, 3.9) SYSTEMS AND KITS

Year	Part Number	Description	Boost Options	HP Gain	Intercooler	Price/MAP
1999-03	1FI202-SCI	Stage II Intercooled System with P-1SC	9, 11 psi	60-80%	2 core	\$6,348
1999-04	1FI200-SCI	Intercooled Tuner Kit with P-1SC	specify	specify	2 core	\$5,798
1994-98	1FJ212-SCI	High Output Intercooled System with P-1SC	11 psi	75-80%	2 core	\$5,578
1994-98	1FJ202-SCI	High Output Intercooled Tuner Kit with P-1SC	specify	specify	2 core	\$5,248

Applications	Part Number Suffix	Description	Upgrade From	Requirements	Notes	Price/MAP
ALL	add "-B" to part #	Supercharger Finish: Black, max 9.75" housing	satin	max 9.75" housing	-	+\$295
	add "-P" to part #	Supercharger Finish: Polished, max 9.75" housing	satin	max 9.75" housing	-	+\$400
	add "-H" to part #	Gears: Helical gearset for noise reduction	straight-cut	P- or D-series only	-	+\$110
	add "-D1SC" to part #	Supercharger Upgrade: D-1SC	P-1SC	Tuner Kits only	-	+\$525
	add "-3C" to part #	Intercooler Upgrade: 3-core air-to-air, 825 HP max	2-core	-	3" tubing	+\$435
4.6L ONLY	add "-SM" to part #	Intercooler Upgrade: Sheet metal 3-core Race, 950 HP max	3-core	4.6L only	3" tubing	+\$345
1999-04 4.6L ONLY	add "D" or "-1" or "-A"	Supercharger Upgrade: F-1D, F-1, F-1A	P-1SC	Tuner Kits only	-	+\$1,100
	add "-BB" to part #	Supercharger Bracket Finish: Black	satin	-	-	+\$225
	add "-PB" to part #	Supercharger Bracket Finish: Polished	satin	-	-	+\$325
	add "-RVR" or "RVB"	Race Blow-off Valve Upgrade (specify open or closed, alum or steel, red or blk)	ProFlow	-	-	+\$295

FOR COYOTE & GODZILLA ENGINE SWAP KITS, SEE PAGE 24

SPECIFICATIONS

1999-04 MUSTANG GT AND 2001 BULLITT (4.6 2V) SPECIFICATIONS

Year	Part Number	OEM hp Rating	HP Gain	Tube Diam	IC Mount	Drive System	Blow-off System	Fuel System Upgrade	Fuel Inj. Supplied	Computer/Ignition Modifications	Supercharger Warranty (in months)	CARB E.O.	Foot Notes
1999-04	1FE212-SCI	260	55-60%	3"	V	stk 6-rib	ProFlow	not required	39.5 lb/hr	programmer supplied	12, 36 opt. (\$99)	D-365-5	E: 1, 4
1999-04	1FE202-SCI	260	specify	3"	V	stk 6-rib	ProFlow	not supplied	No	not supplied	12	-	E: 1, 5, 10
1999-04	1FE211-SCI	260	60-65%	3"	V	stk 6-rib	ProFlow	in-tank pump	39.5 lb/hr	programmer supplied	12, 36 opt. (\$99)	-	E: 1, 3, 4
1999-04	1FE201-SCI	260	specify	3"	V	stk 6-rib	ProFlow	not supplied	No	not supplied	12	-	E: 1, 5, 10
2001	BULLITT	265	55-60%	3"	V	stk 6-rib	ProFlow	As above	As above	As above	As above	D-365-5	As Above

2003-04 MUSTANG MACH 1 (4.6 4V) SPECIFICATIONS

Year	Part Number	OEM hp Rating	HP Gain	Tube Diam	IC Mount	Drive System	Blow-off System	Fuel System Upgrade	Fuel Inj. Supplied	Computer/Ignition Modifications	Supercharger Warranty (in months)	CARB E.O.	Foot Notes
2003-04	1FL212-SCI	300	60-65%	3"	V	stk 6-rib	ProFlow	in-tank pump	39.5 lb/hr	programmer supplied	12, 36 opt. (\$99)	-	E: 1, 3, 4, 9, 10
2003-04	1FL202-SCI	300	specify	3"	V	stk 6-rib	ProFlow	not supplied	No	not supplied	12	-	E: 1, 9, 10

1996-98 MUSTANG GT (4.6 2V) SPECIFICATIONS

Year	Part Number	OEM hp Rating	HP Gain	Tube Diam	IC Mount	Drive System	Blow-off System	Fuel System Upgrade	Fuel Inj. Supplied	Computer/Ignition Modifications	Supercharger Warranty (in months)	CARB E.O.	Foot Notes
1996-98	1FD211-10I	215-225	55-70%	3"	V	stk 6-rib	ProFlow	ProPump, FMU	not required	not required	12, 36 opt. (\$99) @ 8 psi	D-365-3 (10 psi)	E: 1, 4, 9
1996-98	1FD201-SCI	215-225	specify	3"	V	stk 6-rib	ProFlow	not supplied	No	not required	12	-	E: 1, 4, 9
1996-98	1FD212-SCI	215-225	60-80%	3"	V	stk 6-rib	ProFlow	ProPump, FMU	not supplied	not required	12, 36 opt. (\$99) @ 8 psi	-	E: 1, 2, 4, 9
1996-98	1FD202-SCI	215-225	specify	3"	V	stk 6-rib	ProFlow	not supplied	No	not required	12	-	E: 1, 2, 4, 9

1994-04 MUSTANG V6 (3.8, 3.9) SPECIFICATIONS

Year	Part Number	OEM hp Rating	HP Gain	Tube Diam	IC Mount	Drive System	Blow-off System	Fuel System Upgrade	Fuel Inj. Supplied	Computer/Ignition Modifications	Supercharger Warranty (in months)	CARB E.O.	Foot Notes
1999-03	1FI202-SCI	193	60-80%	3"	V	stk 6-rib	ProFlow	in-tank pump	39.5 lb/hr	programmer supplied	12, 36 opt. (\$99) @ 9 psi	-	E: 1, 3, 6, 9
1999-04	1FI200-SCI	193	specify	3"	V	stk 6-rib	ProFlow	not supplied	No	not supplied	12	-	E: 1, 6, 8, 9
1994-98	1FJ212-SCI	145	75-80%	3"	V	stk 6-rib	ProFlow	ProPump, FMU	not required	not required	12, 36 opt. (\$99)	D-365-3	E: 1, 7, 9
1994-98	1FJ202-SCI	145	specify	3"	V	stk 6-rib	ProFlow	not supplied	No	not required	12	-	E: 1, 7, 9

FORD AUTOMOTIVE FOOTNOTES (specific to above applications):

- E1) Model year must be specified
- E2) 24 lb/hr fuel injectors required (not supplied)
- E3) Due to variability among OEM computers, the prevalence of custom modifications and age/miles/condition of vehicles, dyno tuning may be required; Stock vehicles with cat-back exhaust systems may require custom tuning
- E4) Aftermarket mass air sensors will require custom tuning
- E5) D-1SC, F-1, F-1A modified motors only (air inlet may require modification)
- E6) 1999-01 3.8 Mustangs must specify if car is equipped with ABS/Traction control
- E7) 1994-98 3.8 Mustangs with ABS/Traction control module will require custom relocation of that module
- E8) Tuner kits available for 2004 Mustang V6 3.9L models; custom tuning required
- E9) Special order kit: order form and non-refundable deposit required at time of order—may require additional lead time for processing
- E10) Race valve requires welding

2003-04 COBRA (4.6 4V) KITS

Year	Part Number	Description	Boost Options	Max RWHP	Intercooler	Price/MAP
2003-04	1FM202-SCI	High Output Tuner Kit with P-1SC	10-15 psi	550 rwhp	OEM supplied	\$5,798
2003-04	1FM203-SC	Stage II Tuner Kit with F-1D, F-1, or F-1A (6-rib)	10-20 psi	620 rwhp	OEM supplied	\$6,398
2003-04	1FM204-SC-C	Race Kit with F-1D, F-1, or F-1A (cog drive)	18-30+ psi	750+ rwhp	OEM supplied	\$6,948

1999-01 COBRA (4.6 4V) SYSTEMS AND KITS

Year	Part Number	Description	Boost Options	HP Gain	Intercooler	Price/MAP
1999-01	1FF211-SCI	High Output Intercooled System with P-1SC	6 psi max	45-50%	2 core	\$7,648
1999-01	1FF201-SCI	High Output Intercooled Tuner Kit with P-1SC	specify	specify	2 core	\$6,648
1999-01	1FF212-SCI	Stage II Intercooled System with P-1SC	8 psi	60-65%	3 core	\$8,083
1999-01	1FF202-SCI	Stage II Intercooled Tuner Kit with P-1SC	specify	specify	3 core	\$7,083

1996-98 COBRA (4.6 4V) SYSTEMS AND KITS

Year	Part Number	Description	Boost Options	HP Gain	Intercooler	Price/MAP
1996-98	1FC211-10I	HO Intercooled System with P-1SC	6 psi	45-50%	2 core	\$7,598
1996-98	1FC201-SCI	HO Intercooled Tuner Kit with P-1SC	specify	specify	2 core	\$6,648
1996-98	1FC212-SCI	Stage II Intercooled System with P-1SC	8 psi	60-65%	3 core	\$7,998
1996-98	1FC202-SCI	Stage II Intercooled Tuner Kit with P-1SC	specify	specify	3 core	\$7,083

1996-98 COBRA (4.6 4V) RACE KITS

Year	Part Number	Description	Boost Options	HP Gain	Intercooler	Price/MAP
1996-98	1FX205-F1A	Serpentine Race Kit with F-1D, F-1, or F-1A (additional 8-rib)	specify	specify	-	\$6,998
1996-98	1FX244-F1C	Cog Race Kit with F-1C or F-1R	specify	specify	-	\$7,748

Applications	Part Number Suffix	Description	Upgrade From	Requirements	Notes	Price/MAP
FINISH OPTIONS	add "-B" to part #	Supercharger Finish: Black, max 9.75" housing	satin	max 9.75" housing	-	+\$295
	add "-P" to part #	Supercharger Finish: Polished, max 9.75" housing	satin	max 9.75" housing	-	+\$400
	add "-PI" to part #	Sheet Metal Intake Finish: Polished	raw	2003-04 only	-	+\$400
KIT UPGRADES	add "-H" to part #	Gears: Helical gearset for noise reduction	straight-cut	P- or D-series only	-	+\$110
	add "OI" to part #	Omit Cobra intake manifold	-	2003-04 only	-	-\$659
	add "-D1SC" to part #	Supercharger Upgrade: D-1SC	P-1SC	1996-01 Tuner Kits only	-	+\$525
	add "-SM" to part #	Intercooler Upgrade: Sheet metal 3-core Race, 950 HP max	3-core	1996-01 only	3" tubing	+\$345
1996-98 RACE KITS ONLY	add "-3C" to part #	Intercooler Upgrade: 3-core air-to-air, 825 HP max	2-core	1999-01 HO Tuner Kit only	3" tubing	+\$435
	add "-B" to part #	Supercharger Finish: Black, 10.5" housing	satin	10.5" housing	-	+\$395
	add "-P" to part #	Supercharger Finish: Polished, 10.5" housing	satin	10.5" housing	-	+\$500
	add "-C" or "-R" to part #	Supercharger Upgrade: F-1C or F-1R	F-1D, F-1, F-1A	Cog Kit only	-	+\$350
	add "-F2" to part #	Supercharger Upgrade: F-2	F-1C, F-1R	Cog Kit only	-	+\$1,450
	A1045A-001	Intercooler Upgrade: Sheet metal 3-core Race, 1300 HP max	-	-	3.5" in/outlet	+\$1,798
W11005A-001	Intercooler Upgrade: Air-to-Water Race, 1800 HP max	-	-	-	+\$2,498	

FOR COYOTE & GODZILLA ENGINE SWAP KITS, SEE PAGE 24

SPECIFICATIONS

2003-04 COBRA (4.6 4V) SPECIFICATIONS

Year	Part Number	OEM hp Rating	HP Gain	Tube Diam	Intercooler Mount	Drive System	Blow-off System	Fuel System Upgrade	Fuel Inj. Supplied	Computer/Ignition Modifications	Supercharger Warranty (in months)	CARB E.O.	Foot Notes
2003-04	1FM202-SCI	390	specify	-	-	stk 6-rib	ProFlow	not required	No	not supplied	12	-	F: 1, 10
2003-04	1FM203-SC	390	specify	-	-	stk 6-rib	Race	not supplied	No	not supplied	12	-	F: 1, 10
2003-04	1FM204-SC-C	390	specify	-	-	cog	Race	not supplied	No	not supplied	Limited	-	F: 1, 9, 10

1999-01 COBRA (4.6 4V) SPECIFICATIONS

Year	Part Number	OEM hp Rating	HP Gain	Tube Diam	Intercooler Mount	Drive System	Blow-off System	Fuel System Upgrade	Fuel Inj. Supplied	Computer/Ignition Modifications	Supercharger Warranty (in months)	CARB E.O.	Foot Notes
1999-01	1FF211-SCI	320	45-50%	3"	V	stk 6-rib	ProFlow	not required	39.5 lb/hr	programmer supplied	12, 36 opt. (\$99)	-	F: 1, 2, 3
1999-01	1FF201-SCI	320	specify	3"	V	stk 6-rib	ProFlow	not supplied	No	not supplied	12	-	F: 1, 3, 4, F11
1999-01	1FF212-SCI	320	60-65%	3"	V	stk 6-rib	ProFlow	in-tank pump	39.5 lb/hr	programmer supplied	12, 36 opt. (\$99)	-	F: 1, 2, 4
1999-01	1FF202-SCI	320	specify	3"	V	stk 6-rib	ProFlow	not supplied	No	not supplied	12	-	F: 1, 4, F11

1996-98 COBRA (4.6 4V) SPECIFICATIONS

Year	Part Number	OEM hp Rating	HP Gain	Tube Diam	Intercooler Mount	Drive System	Blow-off System	Fuel System Upgrade	Fuel Inj. Supplied	Computer/Ignition Modifications	Supercharger Warranty (in months)	CARB E.O.	Foot Notes
1996-98	1FC211-10I	305	45-50%	3"	V	stk 6-rib	ProFlow	ProPump, FMU	No	programmer supplied	12, 36 opt. (\$99)	-	F: 1, 5, 10
1996-98	1FC201-SCI	305	specify	3"	V	stk 6-rib	ProFlow	not supplied	No	not supplied	12	-	F: 1, 10
1996-98	1FC212-SCI	305	60-65%	3"	V	stk 6-rib	ProFlow	ProPump, FMU	No	programmer supplied	12, 36 opt. (\$99)	-	F: 1, 2, 5, 10
1996-98	1FC202-SCI	305	specify	3"	V	stk 6-rib	ProFlow	not supplied	No	not supplied	12	-	F: 1, 10

1996-98 COBRA (4.6 4V) RACE SPECIFICATIONS

Year	Part Number	OEM hp Rating	HP Gain	Tube Diam	Intercooler Mount	Drive System	Blow-off System	Fuel System Upgrade	Fuel Inj. Supplied	Computer/Ignition Modifications	Supercharger Warranty (in months)	CARB E.O.	Foot Notes
1996-98	1FX205-F1A	n/a	specify	-	-	add'l 8-rib	Race	not supplied	No	not supplied	12	-	F: 1, 6, 8, 10
1996-98	1FX244-F1C	n/a	specify	-	-	cog	Race	not supplied	No	not supplied	Limited	-	F: 1, 6, 7, 8, 10

FORD AUTOMOTIVE FOOTNOTES (specific to above applications):

- F1) Model year must be specified
 F2) Due to variability among OEM computers, the prevalence of custom modifications, and age/miles/condition of vehicles, dyno tuning may be required
 F3) HO Systems and Tuner Kits for 1996-01 Cobras require a cut-down impeller, which limits max boost to 8 psi on stock motors
 F4) 1999-01 model years with over 10 psi boost require Ford Lightning (flange-style) MAF (not supplied)
 F5) 30 lb/hr fuel injectors required (not supplied)
 F6) Modified motors only
 F7) May require cooling system and air conditioning system modifications
 F8) ATI Performance Products aftermarket balancer required, part #918036 (not included - specify hardened hub)
 F9) Battery relocation required (trunk relocation kit supplied)
 F10) Special order kit: order form and non-refundable deposit required at time of order—may require additional lead time for processing
 F11) 1999-2001 may require trimming for Sheet Metal 3-core Race intercooler



1994-95 MUSTANG AND COBRA (5.0) SYSTEMS AND KITS

Year	Part Number	Description	Boost Options	HP Gain	Intercooler	Price/MAP
1994-95	1FB100-09I / 11I / 14I	High Output Intercooled System with P-1SC	9, 11, 14 psi	60-85%	2 core	\$6,198
1994-95	1FB202-SCI	High Output Intercooled Tuner Kit with P-1SC	specify	specify	2 core	\$5,998
1994-95	1FB324-D1SC	Stage II Intercooled System with D-1SC	15-22 psi	85%+	3 core	\$6,998
1994-95	1FB012-SCI	High Output Kit with P-1SC	specify	specify	-	\$4,998

1986-93 MUSTANG AND COBRA (5.0) SYSTEMS AND KITS

Year	Part Number	Description	Boost Options	HP Gain	Intercooler	Price/MAP
1986-93	1FA100-09I / 11I / 14I	High Output Intercooled System with P-1SC (8-rib)	9, 11, 14 psi	60-85%	2 core	\$6,248
1986-93	1FA202-SCI	High Output Intercooled Tuner Kit with P-1SC (8-rib)	specify	specify	2 core	\$5,898
1986-93	1FA324-D1SC-8R	Stage II Intercooled System with D-1SC (8-rib)	15-25 psi	85%+	3 core	\$6,998
1986-93	1FA012-SC	High Output Kit with P-1SC	specify	specify	-	\$4,998

Applications	Part Number Suffix	Description	Upgrade From	Requirements	Notes	Price/MAP
ALL	add "-B" to part #	Supercharger Finish: Black, max 9.75" housing	satin	max 9.75" housing	-	+\$295
	add "-P" to part #	Supercharger Finish: Polished, max 9.75" housing	satin	max 9.75" housing	-	+\$400
	add "-H" to part #	Gears: Helical gearset for noise reduction	straight-cut	-	-	+\$110
	add "-C" to part #	Supercharger Upgrade: P-1SC-1	P-1SC	-	-	+\$220
	add "-P1X" to part #	Supercharger Upgrade: P-1X	P-1SC	-	-	+\$500
	add "-D1SC" to part #	Supercharger Upgrade: D-1SC	P-1SC	-	-	+\$525
	add "-D" or "-1" or "-A"	Supercharger Upgrade: F-1D, F-1, F-1A	D-1SC	Stage II only	-	+\$575
	add "-3C" to part #	Intercooler Upgrade: 3-core air-to-air, 825 HP max	2-core	-	3" tubing	+\$435
	add "-SM" to part #	Intercooler Upgrade: Sheet metal 3-core Race, 950 HP max	3-core	-	3" tubing	+\$345
	add "-OF" to part #	Omit FMU	-	Stage II only	-	-\$88
	add "-OP" to part #	Omit in-line fuel pump	-	Stage II only	-	-\$98
	add "-RVR" or "-RVB"	Race Blow-off Valve Upgrade (specify open or closed, alum or steel, red or blk)	ProFlow	-	-	+\$295
	1986-93 ONLY	add "-BB" to part #	Supercharger Bracket Finish: Black	satin	-	-
add "-PB" to part #		Supercharger Bracket Finish: Polished	satin	-	-	+\$325
add "-BV" to part #		Bullet Blow-off Valve Upgrade (black only)	ProFlow	HO only	-	+\$125
add "-THF" to part #		Intercooler Upgrade: Twin Highflow, 850 HP max	3-core	-	2.5-3" tubing	+\$295
AB003A-010		Alternator relocation kit with power steering (non A/C vehicles)	-	-	-	+\$545

FOR COYOTE & GODZILLA ENGINE SWAP KITS, SEE PAGE 24

SPECIFICATIONS

1994-95 MUSTANG, COBRA (5.0) SPECIFICATIONS

Year	Part Number	OEM hp Rating	HP Gain	Tube Diam	IC Mount	Drive System	Blow-off System	Fuel System Upgrade	Fuel Inj. Supplied	Computer/Ignition Modifications	Supercharger Warranty (in months)	CARB E.O.	Foot Notes
1994-95	1FB100-09I / 11I / 14I	215/240	60-85%	3"	V	stk 6-rib	ProFlow	ProPump, FMU	not req.	not required	12, 36 opt. (\$99) @ 9 psi	D-365-3	G: 1, 2, 3, 4, 5, 10
1994-95	1FB202-SCI	215/240	specify	3"	V	stk 6-rib	ProFlow	not supplied	not req.	not required	12	-	G: 1, 2, 3, 4, 5, 10
1994-95	1FB324-D1SC	215/240	85%+	3"	V	stk 6-rib	ProFlow	ProPump, FMU	No	not required	12	-	G: 1, 2, 3, 4, 5, 10
1994-95	1FB012-SCI	215/240	specify	-	-	stk 6-rib	ProFlow	ProPump, FMU	No	not supplied	12	-	G: 1, 2, 3, 4, 5, 10

1986-93 MUSTANG, COBRA (5.0) SPECIFICATIONS

Year	Part Number	OEM hp Rating	HP Gain	Tube Diam	IC Mount	Drive System	Blow-off System	Fuel System Upgrade	Fuel Inj. Supplied	Computer/Ignition Modifications	Supercharger Warranty (in months)	CARB E.O.	Foot Notes
1986-93	1FA100-09I / 11I / 14I	205-235	60-85%	3"	V / H	add'l 8-rib	ProFlow	ProPump, FMU	not req.	not required	12, 36 opt. (\$99) @ 9 psi	D-365-3	G: 1, 2, 6, 9, 12
1986-93	1FA202-SCI	205-235	specify	3"	V / H	add'l 8-rib	ProFlow	not supplied	not req.	not required	12	-	G: 1, 2, 6, 9, 12
1986-93	1FA324-D1SC-8R	205-235	85%+	3"	V / H	add'l 8-rib	ProFlow	ProPump, FMU	No	not required	12	-	G: 1, 2, 6, 7, 9, 12
1986-93	1FA012-SC	205-235	specify	3"	-	add'l 8-rib	ProFlow	FMU	No	not supplied	12	-	G: 1, 2, 8, 9, 12

FORD AUTOMOTIVE FOOTNOTES (specific to above applications):

- G1) Model year must be specified
 G2) Standard ProCharger bracket requires factory a/c and p/s
 G3) Specify stock or bullet-style MAF flange
 G4) Battery relocation required (trunk relocation kit supplied)
 G5) Cobra balancer must be replaced with GT balancer, Ford part #F4ZZ6A312A (not supplied)
 G6) GT models can have either vertical or horizontal intercooler mounting; horizontal intercooler or Twin Highflow mounting recommended for LX models; vertical mounting possible with modifications; vertical mounting or Twin Highflow recommended for all lowered vehicles
 G7) Inner fender modification may be required
 G8) Specify stock or cowl hood (additional charge for stock hood—requires alternate tubing)
 G9) For speed density models (most 1986-88) MAF conversion is recommended (not supplied)
 G10) Special order kit: order form and non-refundable deposit required at time of order—may require additional lead time for processing
 G12) Non A/C vehicles require power steering relocation kit (AB003A-010)

***NEW* SBF SERPENTINE ACCESSORY DRIVE KIT (PROCHARGER OPTIONAL)**

Year	Part Number	Description	Boost Options	HP Gain	Intercooler	Price/MAP
specify	1EX300	Serpentine Accessory Drive (with crank pulley + alternator bracket)	-	-	-	\$2,398
specify	1EX300-PS	Serpentine Accessory Drive (with crank pulley + alternator bracket & p/s bracket)	-	-	-	\$2,698
specify	1EX300-AC	Serpentine Accessory Drive (with crank pulley + alternator bracket & a/c bracket)	-	-	-	\$2,598
specify	1EX300-PS-AC	Serpentine Accessory Drive (with crank pulley + alt bracket, p/s bracket & a/c bracket)	-	-	-	\$2,898
specify	1EX400-P1SC	Serpentine Accessory Drive Kit with P-1SC-1 (with all accessory brackets)	specify	specify	-	\$6,198
specify	1EX400-P1SC-I	Serpentine Accessory Drive Kit with Intercooled P-1SC-1 (with all acc brackets)	specify	specify	2 core 550 hp	\$7,098
specify	1EX400-P1X	Serpentine Accessory Drive Kit with P-1X (with all accessory brackets)	specify	specify	-	\$6,448
specify	1EX400-P1X-I	Serpentine Accessory Drive Kit with Intercooled P-1X (with all accessory brackets)	specify	specify	2 core 550 hp	\$7,348
specify	1EX400-D1SC	Serpentine Accessory Drive Kit with D-1SC (with all accessory brackets)	specify	specify	-	\$6,448
specify	1EX400-D1SC-I	Serpentine Accessory Drive Kit with Intercooled D-1SC (with all accessory brackets)	specify	specify	3 core 825 hp	\$7,798
specify	1EX400-D1X	Serpentine Accessory Drive Kit with D-1X (with all accessory brackets)	specify	specify	-	\$6,648
specify	1EX400-D1X-I	Serpentine Accessory Drive Kit with Intercooled D-1X (with all acc brackets)	specify	specify	3 core 825 hp	\$7,898
specify	1EX400-P1R	Serpentine Accessory Drive Kit with P-1R (with all accessory brackets)	specify	specify	-	\$6,748
specify	1EX400-P1R-I	Serpentine Accessory Drive Kit with Intercooled P-1R (with all accessory brackets)	specify	specify	3 core 825 hp	\$7,998
specify	1EX400-F1D/F1/F1A	Serpentine Accessory Drive Kit with F-1D, F-1, or F-1A (with all accessory brackets)	specify	specify	-	\$7,648
specify	1EX400-F1D-I/F1-I/F1A-I	Serpentine Accessory Drive Kit with Intercooled F-1D, F-1, or F-1A (with all acc brackets)	specify	specify	3 core 950 hp	\$9,098
specify	1EX400-F1A94/F1C/F1R	Serpentine Accessory Drive Kit with F-1A-94, F-1C or F-1R (with all accessory brackets)	specify	specify	-	\$8,048
specify	1EX400-F1A94-I/F1C-I/F1R-I	Serpentine Accessory Drive Kit with Intercooled F-1A-94, F-1C or F-1R (with all acc brackets)	specify	specify	3 core 1050 hp	\$9,728
specify	1EX400-103	Serpentine Accessory Drive Kit with F-1R-103 (with all accessory brackets)	specify	specify	-	\$9,278
specify	1EX400-103-I	Serpentine Accessory Drive Kit with Intercooled F-1R-103 (with all accessory brackets)	specify	specify	3 core 1300 hp	\$10,848
specify	1EX400-F1X	Serpentine Accessory Drive Kit with F-1X (10-rib) (with all accessory brackets)	specify	specify	-	\$9,778
specify	1EX400-F1X-I	Serpentine Accessory Drive Kit with Intercooled F-1X (10-rib) with all acc brackets)	specify	specify	3 core 1300 hp	\$11,348
specify	1EX400-F2	Serpentine Accessory Drive Kit with F-2 (10-rib) (with all accessory brackets)	specify	specify	-	\$9,998
specify	1EX400-F2-I	Serpentine Accessory Drive Kit with Intercooled F-2 (10-rib) (with all acc brackets)	specify	specify	3 core 1300 hp	\$11,548

Type	Part Number Suffix	Description	Upgrade From	Requirements	Notes	Price/MAP
ACCESSORIES	omit "OPB"	Omit power steering belt, bracket & pulley, satin finish	1EX400	-	-	-\$300
	omit "OAB"	Omit air conditioning bracket & pulley, satin finish	1EX400	-	-	-\$200
	3LSBB-006	Add ProCharger supercharger bracket 8-rib, tensioner & belt, satin finish	1EX300	-	-	+\$650
	GA100I-009	Add SBF Water Pump 86-93, satin finish	no Water Pump	-	-	+\$89
	GA100I-009B	Add SBF Water Pump 86-93, black finish	no Water Pump	-	-	+\$123
	GA100I-009P	Add SBF Water Pump 86-93, polished finish	no Water Pump	-	-	+\$137
	GA100I-008	Add SBF Alternator 150 AMP 3G, satin finish	no Alternator	-	-	+\$385
	GA100I-008B	Add SBF Alternator 150 AMP 3G, black finish	no Alternator	-	-	+\$390
	GA100I-008P	Add SBF Alternator 150 AMP 3G, polished finish	no Alternator	-	-	+\$515
	GA100I-002	Add Power Steering Pump GM Type 2, satin finish	no P/S	-	-	+\$160
	GA100I-002B/P	Add Power Steering Pump GM Type 2, black or polished finish	no P/S	-	-	+\$242
	GA100I-001(B)	Add A/C Compressor Sanden SD-7B10, satin or black finish	no A/C	-	-	+\$260
	GA100I-001P	Add A/C Compressor Sanden SD-7B10, polished finish	no A/C	-	-	+\$502
	FINISH OPTIONS	add "-B" to part #	Supercharger Finish: Black, max 9.75" housing	satin	max 9.75" housing	-
add "-P" to part #		Supercharger Finish: Polished, max 9.75" housing	satin	max 9.75" housing	-	+\$400
add "-BB" to part #		Supercharger Bracket Finish: Black	satin	-	-	+\$225
add "-PB" to part #		Supercharger Bracket Finish: Polished	satin	-	-	+\$325
add "-BA" to part #		Accessory Bracket Finish: Black	satin	-	-	+\$250
KIT UPGRADES	add "-PA" to part #	Accessory Bracket Finish: Polished	satin	-	-	+\$350
	add "-H" to part #	Gears: Helical gears for noise reduction	straight-cut	P- or D-series only	-	+\$110
INTERCOOLERS	add "-10R" to part #	10-rib drive system upgrade	8-rib	-	-	+\$360
	SEE PAGES 94-95 FOR INTERCOOLER UPGRADE AND INTAKE MANIFOLD OPTIONS AND DIMENSIONS					
CARB HATS	AM006A-001	Low Profile Carb Hat 4150, satin finish	-	-	3" inlet, 2" height	+\$180
	AM009A-001	Standard Carb Hat 4150, satin finish	-	-	3.5" inlet, 2.75" height	+\$242
	AM001A-001	Competition Carb Hat 4150, satin finish	-	-	3.5" inlet, 4.5" height	+\$292
	add "-BB" to part #	Carb Hat Finish: Black	satin	-	-	+\$100
	add "-PB" to part #	Carb Hat Finish: Polished	satin	-	-	+\$100

SPECIFICATIONS

***NEW* SBF SERPENTINE ACCESSORY DRIVE KIT SPECIFICATIONS**

Year	Part Number	Stock HP	HP Gain	Tube Diam	Carb Hat	Drive System	Blow-off Valve	Water Pump	Alternator Bracket	Power Steering Bracket	Air Cond. Bracket	Supercharger Warranty (in months)	Tubing Supplied	Foot Notes
specify	1EX300	N/A	specify	-	optional	6-rib Acc Drive	-	-	included	-	-	-	-	all
specify	1EX300-PS	N/A	specify	-	optional	6-rib / 8-rib	-	-	included	included	-	-	-	all
specify	1EX300-AC	N/A	specify	-	optional	6-rib Acc Drive	-	-	included	-	included	-	-	all
specify	1EX300-PS-AC	N/A	specify	-	optional	6-rib / 8-rib	-	-	included	included	included	-	-	all
specify	1EX400-P1SC	N/A	specify	-	optional	6-rib Acc Drive	ProFlow	-	included	included	included	12	-	all
specify	1EX400-P1SC-I	N/A	specify	-	optional	6-rib / 8-rib	ProFlow	-	included	included	included	12	-	all
specify	1EX400-P1X	N/A	specify	-	optional	6-rib Acc Drive	ProFlow	-	included	included	included	12	-	all
specify	1EX400-P1X-I	N/A	specify	-	optional	6-rib / 8-rib	ProFlow	-	included	included	included	12	-	all
specify	1EX400-D1SC	N/A	specify	-	optional	6-rib / 8-rib	ProFlow	-	included	included	included	12	-	all
specify	1EX400-D1SC-I	N/A	specify	3"	optional	6-rib / 8-rib	ProFlow	-	included	included	included	12	yes	all
specify	1EX400-D1X	N/A	specify	-	optional	6-rib / 8-rib	ProFlow	-	included	included	included	12	-	all
specify	1EX400-D1X-I	N/A	specify	3"	optional	6-rib / 8-rib	ProFlow	-	included	included	included	12	yes	all
specify	1EX400-P1R	N/A	specify	-	optional	6-rib / 8-rib	ProFlow	-	included	included	included	12	-	all
specify	1EX400-P1R-I	N/A	specify	3"	optional	6-rib / 8-rib	ProFlow	-	included	included	included	12	yes	all
specify	1EX400-F1D/F1/F1A	N/A	specify	-	optional	6-rib / 8-rib	ProFlow	-	included	included	included	12	-	all
specify	1EX400-F1D-I/F1-I/F1A-I	N/A	specify	3"	optional	6-rib / 8-rib	ProFlow	-	included	included	included	12	yes	all
specify	1EX400-F1A94/F1C/F1R	N/A	specify	-	optional	6-rib / 8-rib	Race Valve	-	included	included	included	12	-	all
specify	1EX400-F1A94-I/F1C-I/F1R-I	N/A	specify	3"	optional	6-rib / 8-rib	Race Valve	-	included	included	included	12	yes	all
specify	1EX400-103	N/A	specify	-	optional	6-rib / 8-rib	Race Valve	-	included	included	included	12	-	all
specify	1EX400-103-I	N/A	specify	3.5"	optional	6-rib / 8-rib	Race Valve	-	included	included	included	12	yes	all
specify	1EX400-F1X	N/A	specify	-	optional	6-rib / 10-rib	Race Valve	-	included	included	included	12	-	all
specify	1EX400-F1X-I	N/A	specify	3.5"	optional	6-rib / 10-rib	Race Valve	-	included	included	included	12	yes	all
specify	1EX400-F2	N/A	specify	-	optional	6-rib / 10-rib	Race Valve	-	included	included	included	12	-	all
specify	1EX400-F2-I	N/A	specify	3.5"	optional	6-rib / 10-rib	Race Valve	-	included	included	included	12	yes	all

FORD AUTOMOTIVE FOOTNOTES (specific to above applications):

- FA1) Carbureted systems require Holley 4150 series or similar blow-through carburetor (sold separately by others) and fuel system upgrade (sold separately by ProCharger and others)
- FA2) Specify Universal or Fox Body intercooler kit and tubing
- FA3) Universal intercooler tubing kit, not designed for a specific vehicle
- FA4) ProCharger pulleys do not line up with factory (OEM) 6-rib accessory pulleys—realignment of factory accessories is required
- FA5) Specify engine deck height
- FA6) Specify with or without A/C
- FA7) Factory or aftermarket 86-93 balancer required
- FA8) Alternator bracket option requires 3G alternator
- FA9) Power steering pump bracket option requires GM Type 2 p/s pump



FOR MORE INFORMATION:
SCAN CODE WITH PHONE OR VISIT:
PROCHARGER.COM/SBF-SERPENTINE-ACCESSORY-DRIVE-KIT

COMPATIBLE ACCESSORIES

Description	Part #	Manufacturer/Notes
A/C Compressor	SD-7B10	Sanden, 6-rib
Alternator	7768E	Tuff Stuff (or equivalent), 150 AMP 3G
Power Steering Pump	6175AL	Tuff Stuff (or equivalent), GM Type 2
Water Pump	1594NE	Tuff Stuff (or equivalent), 86-93



CARBURETED AND AFTERMARKET EFI FORD SB SERPENTINE KITS (WINDSOR/YATES BASED, 85-93 MUSTANG ACCESSORIES)

Year	Part Number	Description	Boost Options	HP Gain	Intercooler	Price/MAP
1985-93	1FX012-P1SC	High Output Kit with P-1SC (8-rib)	specify	specify	-	\$4,998
1985-93	1FX212-P1SC-I	High Output Intercooled Kit with P-1SC (8-rib)	specify	specify	2 core (550hp)	\$6,148
1985-93	1FX022-D1SC	High Output Kit with D-1SC (12-rib)	specify	specify	-	\$5,648
1985-93	1FX222-D1SC-I	High Output Intercooled Kit with D-1SC (12-rib)	specify	specify	3 core (825hp)	\$6,898
1985-93	1FX024-F1A94/F1C/F1R	8-rib Race Kit with F-1A-94, F-1C or F-1R (EFI Renegade)	specify	specify	-	\$6,898
1985-93	1FX124-F1D/F1F/F1A	High Output Kit with F-1D, F-1, or F-1A (12-rib)	specify	specify	-	\$6,798
1985-93	1FX324-F1D-I/F1J/F1A-I	High Output Intercooled Kit with F-1D, F-1, or F-1A (12-rib)	specify	specify	Sht mtl 3C (950hp)	\$8,448
1985-93	1FX022-F1A94/F1C/F1R	High Output Kit with F-1A-94, F-1C or F-1R (12-rib)	specify	specify	-	\$7,448
1985-93	1FX124-F1A94-I/F1C-I/F1R-I	High Output Intercooled Kit with F-1A-94, F-1C or F-1R (12-rib)	specify	specify	Sht mtl 3C (1050hp)	\$8,798

1964 1/2-66 MUSTANG AND EARLY FORD (289, 302, 351 V8) KITS

Year	Part Number	Description	Boost Options	HP Gain	Intercooler	Price/MAP
1964.5-66	1FX400-P1SC	High Output Kit with P-1SC (8-rib)	specify	specify	-	\$4,998
1964.5-66	1FX400-P1SC-I	High Output Intercooled Kit with P-1SC (8-rib)	specify	specify	2 core (550hp)	\$6,248

Type	Part Number Suffix	Description	Upgrade From	Requirements	Notes	Price/MAP
FINISH OPTIONS	add "-B" to part #	Supercharger Finish: Black, max 9.75" housing	satn	max 9.75" housing	-	+\$295
	add "-P" to part #	Supercharger Finish: Polished, max 9.75" housing	satn	max 9.75" housing	-	+\$400
	add "-BB" to part #	Supercharger Bracket Finish: Black	satn	-	-	+\$225
	add "-PB" to part #	Supercharger Bracket Finish: Polished	satn	-	-	+\$325
	add "-BC" to part #	Carb Hat Finish: Black	satn	-	-	+\$100
	add "-PC" to part #	Carb Hat Finish: Polished	satn	-	-	+\$150
	add "-BPB" to part #	Power Steering Bracket Finish: Black	satn	-	-	+\$150
	add "-PPB" to part #	Power Steering Bracket Finish: Polished	satn	-	-	+\$200
	add "-BAB" to part #	Alternator Bracket Finish: Black	satn	-	-	+\$150
add "-PAB" to part #	Alternator Bracket Finish: Polished	satn	-	-	+\$200	
SUPER-CHARGERS	add "-P1X" to part #	Supercharger Upgrade: P-1X	P-1SC	-	add'l 10-15+ hp	+\$500
	add "-P1R" to part #	Supercharger Upgrade: P-1R	P-1SC	-	-	+\$800
	add "-D1SC" to part #	Supercharger Upgrade: D-1SC	P-1SC	-	-	+\$525
	add "-D1X" to part #	Supercharger Upgrade: D-1X	P-1SC	-	-	+\$700
	add "-D1X" to part #	Supercharger Upgrade: D-1X	D-1SC	-	-	+\$200
	add "-D" or "-1" or "-A"	Supercharger Upgrade: F-1D, F-1, F-1A	D-1SC	-	-	+\$575
	add "-94" to part #	Supercharger Upgrade: F-1A-94	D-1SC	-	-	+\$925
	add "-103" to part #	Supercharger Upgrade: F-1R-103	D-1SC	-	-	+\$1,975
KIT UPGRADES	add "-H" to part #	Gears: Helical gearset for noise reduction	straight-cut	P- or D-series only	-	+\$110
	add "-BV" to part #	Bullet Blow-off Valve Upgrade (black only)	ProFlow	-	-	+\$125
	add "-RVR" or "RVB"	Race Blow-off Valve Upgrade (specify open or closed, alum or steel, red or blk)	ProFlow	-	-	+\$295
	AV008A-001	ProFlow Blow-off Valve (specify red or black)	-	-	-	+\$268
	AV006A-003	Bullet Blow-off Valve (specify open or closed)	-	-	-	+\$388
	3FASS-00X	Race Blow-off Valve (specify open or closed, alum or steel, red or black)	-	-	-	+\$498
	add "-CB" to part #	Carb Hat Upgrade: Competition 4150 (at time of purchase)	standard	-	3.5" inlet, 4.5" height	+\$50
	AB003A-010	Alternator relocation kit with power steering (non A/C vehicles)	-	-	-	+\$545
	3FAAT-003	Alternator Bracket (requires 1985-93 alternator)	-	1964.5-1966 only	-	+\$495
	FV001I-BST	Boost sensitive fuel pressure regulator (EFI or Carb)	-	-	-	+\$285
	FV002I-BST	Boost sensitive fuel pressure regulator (Carb only, 1000hp capable)	-	-	-	+\$315
	FP001I-002	ProPump fuel pump 700 hp	-	-	-	+\$330
	FP001I-006	High performance 1000 hp electric fuel pump	-	-	-	+\$438
add "-NB"	1964.5-72 Narrow engine bay 8-rib Bracket (non A/C)	-	-	-	+\$75	

OPTIONS FOR THIS PAGE

FOR COYOTE & GODZILLA ENGINE SWAP KITS, SEE PAGE 24

SPECIFICATIONS

CARBURETED, AFTERMARKET EFI FORD SB SERPENTINE KITS (WINDSOR/YATES BASED, 1985-93 MUSTANG ACCESSORIES) SPECIFICATIONS

Year	Part Number	HP Gain	Tube Diam	Carb Hat	Drive System	Blow-off Valve	Alternator Relocation Kit	Alternator with P/S Relocation Kit	Tubing Supplied	SC Warranty (in months)	Foot Notes
1985-93	1FX012-P1SC	specify	-	Low profile	add'l 8-rib	Sold separately	Optional	Optional	-	12	H: 1, 5, 6, 7
1985-93	1FX212-P1SC-I	specify	3"	Standard	add'l 8-rib	ProFlow	Optional	Optional	Yes	12	H: 1, 2, 5, 6, 7
1985-93	1FX022-D1SC	specify	-	Standard	add'l 12-rib	Sold separately	Optional	Optional	-	12	H: 1, 5, 6, 7
1985-93	1FX222-D1SC-I	specify	3"	Standard	add'l 12-rib	ProFlow	Optional	Optional	Yes	12	H: 1, 2, 5, 6, 7
1985-93	1FX024-F1A94/F1C/F1R	specify	-	-	add'l 8-rib	Race Valve	N/A	N/A	-	12	H: 1, 2, 5, 6, 7
1985-93	1FX124-F1D/F1F/F1A	specify	-	Standard	add'l 12-rib	Race Valve	Optional	Optional	-	12	H: 1, 5, 6, 7
1985-93	1FX324-F1D-I/F1J/F1A-I	specify	3"	Standard	add'l 12-rib	Race Valve	Optional	Optional	Yes	12	H: 1, 2, 5, 6, 7
1985-93	1FX022-F1A94/F1C/F1R	specify	-	Standard	add'l 12-rib	Race Valve	Optional	Optional	-	12	H: 1, 5, 6, 7
1985-93	1FX124-F1A94-I/F1C-I/F1R-I	specify	3.5"	Standard	add'l 12-rib	Race Valve	Optional	Optional	Yes	12	H: 1, 2, 3, 5, 6, 7

1964 1/2-66 MUSTANG AND EARLY FORD (289, 302, 351 V8) SPECIFICATIONS

Year	Part Number	HP Gain	Tube Diam	Carb Hat	Drive System	Blow-off Valve	Power Steering Bracket	Alternator Bracket	Tubing Supplied	SC Warranty (in months)	Foot Notes
1964.5-66	1FX400-P1SC	specify	-	Standard	add'l 8-rib	ProFlow	Optional	Optional	-	12	H: 8, 9, 10
1964.5-66	1FX400-P1SC-I	specify	3"	Standard	add'l 8-rib	ProFlow	Optional	Optional	Yes	12	H: 8, 9, 10

Call for '69-'73 Mustang, '66-'73 Fairlane, Maverick, Comet, Falcon, Torino

FORD AUTOMOTIVE FOOTNOTES (specific to above applications):

- H1) Carbureted systems require Holley 4150 series or similar blow-through carburetor (sold separately by others) and fuel system upgrade (sold separately by ProCharger and others)
- H2) Specify Universal or Fox Body intercooler kit and tubing
- H3) Universal intercooler tubing kit, not designed for a specific vehicle
- H4) ProCharger pulleys do not line up with factory (OEM) 6-rib accessory pulleys—realignment of factory accessories is required
- H5) Specify engine deck height
- H6) Specify Windsor or Yates cylinder heads
- H7) Specify with or without P/S; does not work with A/C
- H8) Factory balancer required
- H9) Alternator bracket option requires 1986-93 Fox Body alternator
- H10) Power steering pump bracket option requires 1986-93 Fox Body p/s pump



CARBURETED AND AFTERMARKET EFI FORD SB COG RACE KITS (1985-93 MUSTANG ACCESSORIES)

Year	Part Number	Description	Boost Options	HP Gain	Intercooler	Price/MAP
1985-93	1FX224-F1D/F1/F1A	Cog Race Kit with F-1D, F-1, F-1A	specify	specify	-	\$6,998
1985-93	1FX234-F1D-I/F1-I/F1A-I	Intercooled Cog Race Kit with F-1D, F-1, or F-1A	specify	specify	Sht mtl 3C (950hp)	\$8,498
1985-93	1FX224-F1C/F1R	Cog Race Kit with F-1C, F-1R	specify	specify	-	\$7,448
1985-93	1FX234-F1C-I/F1R-I	Intercooled Cog Race Kit with F-1C or F-1R	specify	specify	Sht mtl 3C (1050hp)	\$8,898
1985-93	1FX224-F1X	Cog Race Kit with F-1X	specify	specify	-	\$7,998
1985-93	1FX234-F1X-I	Intercooled Cog Race Kit with F-1X	specify	specify	Sht mtl 3C (1300hp)	\$9,648
1985-93	1FX224-F2	Cog Race Kit with F-2	specify	specify	-	\$8,548
1985-93	1FX234-F2-I	Intercooled Cog Race Kit with F-2	specify	specify	Sht mtl 3C (1300hp)	\$10,148
1985-93	1FX224-F3A-spec	Cog Race Kit with F-3R-121	specify	specify	-	\$9,548
1985-93	1FX224-F3R-spec	Cog Race Kit with F-3R-130 or F-3R-136	specify	specify	-	\$9,998
1985-93	1FX223-F1R	Reverse Race Kit with F-1R	specify	specify	-	\$7,978
1985-93	1FX223-F1X	Reverse Race Kit with F-1X	specify	specify	-	\$8,548
1985-93	1FX223-F2R	Reverse Race Kit with F-2	specify	specify	-	\$8,848
1985-93	1FX223-F3AR-spec	Reverse Race Kit with F-3R-121	specify	specify	-	\$10,498
1985-93	1FX223-F3RR-spec	Reverse Race Kit with F-3R-13N (specify 130 or 136)	specify	specify	-	\$10,848

Type	Part Number Suffix	Description	Upgrade From	Requirements	Notes	Price/MAP
FINISH OPTIONS	add "B" to part #	Supercharger Finish: Black, max 9.75" housing	satn	max 9.75" housing	-	+\$295
	add "P" to part #	Supercharger Finish: Polished, max 9.75" housing	satn	max 9.75" housing	-	+\$400
	add "B" to part #	Supercharger Finish: Black, 10.5" housing	satn	10.5" housing	-	+\$395
	add "P" to part #	Supercharger Finish: Polished, 10.5" housing	satn	10.5" housing	-	+\$500
	add "B" to part #	Supercharger Finish: Black, 12" housing	satn	12" housing	-	+\$650
	add "P" to part #	Supercharger Finish: Polished, 12" housing	satn	12" housing	-	+\$750
	add "BB" to part #	Supercharger Bracket Finish: Black	satn	-	-	+\$225
	add "PB" to part #	Supercharger Bracket Finish: Polished	satn	-	-	+\$325
	add "BC" to part #	Carb Hat Finish: Black	satn	-	-	+\$100
	add "PC" to part #	Carb Hat Finish: Polished	satn	-	-	+\$150
SUPER-CHARGERS	add "A91" to part #	Supercharger Upgrade: F-1A-91	F-1D, F-1, F-1A	-	-	+\$350
	add "A94" to part #	Supercharger Upgrade: F-1A-94	F-1D, F-1, F-1A	-	-	+\$350
	add "103" to part #	Supercharger Upgrade: F-1R-103	F-1D, F-1, F-1A	-	-	+\$1,400
	add "112" to part #	Supercharger Alternative: F-1X-12 or F-3R-112	F-3R-121	-	-	-\$300
KIT UPGRADES	3FASS-00X	Race Blow-off Valve (specify open or closed, alum or steel, red or black)	-	-	-	included
	add "PRV" to part #	ProRace Blow-off Valve Upgrade (specify red or black)	Race	-	v-band clamp	+\$270
	add "CV" to part #	Competition Blow-off Valve Upgrade (specify red or black)	Race	-	-	+\$50
	add "CV2" to part #	Pair (2) Competition Blow-off Valve Upgrade Kit (specify red or black)	ProRace	-	-	+\$598
	add "CB" to part #	Carb Hat Upgrade: Competition 4150 (at time of purchase)	standard	-	3.5" inlet, 4.5" height	+\$50
	AM001A-001	Competition Carb Hat 4150, satin finish	-	-	3.5" inlet, 4.5" height	+\$292
	FV002I-BST	Boost sensitive fuel pressure regulator (Carb only, 1000hp capable)	-	-	-	+\$315
FP001I-006	High Performance 1000 hp electric fuel pump	-	-	-	+\$438	
INTERCOOLERS	SEE PAGES 94-95 FOR INTERCOOLER UPGRADE AND INTAKE MANIFOLD OPTIONS AND DIMENSIONS					

FOR COYOTE & GODZILLA TRANSPLANT KITS, SEE PAGE 24

SPECIFICATIONS

CARBURETED, AFTERMARKET EFI FORD SB COG RACE KIT (1985-93 MUSTANG ACCESSORIES) SPECIFICATIONS

Year	Part Number	HP Gain	Tube Diam	Carb Hat	Drive System	Blow-off Valve	Alternator Relocation Kit	Alternator with P/S Relocation Kit	Tubing Supplied	SC Warranty (in months)	Foot Notes
1985-93	1FX224-F1D/F1/F1A	specify	-	Standard	8 x 50 mm Cog	Race Valve	Optional	N/A	-	Limited	I: 1, 2, 5, 6
1985-93	1FX234-F1D-I/F1-I/F1A-I	specify	3"	Standard	8 x 50 mm Cog	Race Valve	Optional	N/A	Yes	Limited	I: 1, 2, 3, 5, 6
1985-93	1FX224-F1C/F1R	specify	-	Standard	8 x 50 mm Cog	Race Valve	Optional	N/A	-	Limited	I: 1, 2, 5, 6
1985-93	1FX234-F1C-I/F1R-I	specify	3"	Standard	8 x 50 mm Cog	Race Valve	Optional	N/A	Yes	Limited	I: 1, 2, 4, 5, 6
1985-93	1FX224-F1X	specify	-	Standard	8 x 50 mm Cog	Race Valve	Optional	N/A	-	Limited	I: 1, 2, 5, 6
1985-93	1FX234-F1X-I	specify	3"	Standard	8 x 50 mm Cog	Race Valve	Optional	N/A	Yes	Limited	I: 1, 2, 4, 5, 6
1985-93	1FX224-F2	specify	-	Standard	8 x 50 mm Cog	Race Valve	Optional	N/A	-	Limited	I: 1, 2, 5, 6, 7
1985-93	1FX234-F2-I	specify	3.5"	Standard	8 x 50 mm Cog	Race Valve	Optional	N/A	Yes	Limited	I: 1, 2, 4, 5, 6
1985-93	1FX224-F3A-spec	specify	-	-	14 x 55 mm Cog	ProRace Valve	Optional	N/A	-	Limited	I: 1, 2, 5, 6
1985-93	1FX224-F3R-spec	specify	-	-	14 x 55 mm Cog	ProRace Valve	Optional	N/A	-	Limited	I: 1, 2, 5, 6, 7
1985-93	1FX223-F1R	specify	-	-	8 x 75 mm Cog	Race Valve	N/A	N/A	-	Limited	I: 1, 5, 6
1985-93	1FX223-F1X	specify	-	-	8 x 75 mm Cog	Race Valve	N/A	N/A	-	Limited	I: 1, 5, 6
1985-93	1FX223-F2R	specify	-	-	8 x 75 mm Cog	Race Valve	N/A	N/A	-	Limited	I: 1, 5, 6
1985-93	1FX223-F3RR-spec	specify	-	-	8 x 75 mm Cog	ProRace Valve	N/A	N/A	-	Limited	I: 1, 5, 6
1985-93	1FX223-F3RR-spec	specify	-	-	8 x 75 mm Cog	ProRace Valve	N/A	N/A	-	Limited	I: 1, 5, 6

FORD AUTOMOTIVE FOOTNOTES (specific to above applications):

- 1) Carbureted systems require Holley 4150 series or similar blow-through carburetor (sold separately by others) and fuel system upgrade (sold separately by ProCharger and others)
- 2) Specify universal or Fox Body intercooler kit tubing
- 3) Universal intercooler tubing kit, not designed for a specific vehicle
- 4) ProCharger pulleys do not line up with factory (OEM) 6-rib accessory pulleys—realignment of factory accessories is required
- 5) Specify engine deck height
- 6) Specify Windsor or Yates cylinder heads
- 7) Special order kit: order form and non-refundable deposit required at time of order—may require additional lead time for processing



COYOTE ENGINE SWAP (5.0 4V) SERPENTINE KITS - REVERSE MOUNT

Year	Part Number	Description	Boost Options	HP Gain	Intercooler	Price/MAP
specify	1FA500-P1SC1-I	High Output Intercooled Tuner Kit with P-1SC-1	specify	specify	HO	\$7,398
specify	1FA500-P1SC1	High Output Tuner Kit with P-1SC-1	specify	specify	-	\$5,998
specify	1FA500-F1-I	High Output Intercooled Kit with F-1D, F-1 or F-1A	specify	specify	Stage II	\$8,998
specify	1FA500-F1	High Output Kit with F-1D, F-1, or F-1A	specify	specify	-	\$7,448
specify	1FA500-F1C-I/F1R-I	High Output Intercooled Kit with F-1A-94, F-1C or F-1R	specify	specify	Stage II	\$9,348
specify	1FA500-F1C/F1R	High Output Kit with F-1A-94, F-1C or F-1R	specify	specify	-	\$7,998

COYOTE ENGINE SWAP (5.0 4V) SERPENTINE & COG KITS - STANDARD MOUNT

Year	Part Number	Description	Boost Options	HP Gain	Intercooler	Price/MAP
specify	1FA300-P1SC1-I	High Output Intercooled Tuner Kit with P-1SC-1	specify	specify	HO	\$7,398
specify	1FA300-P1SC1	High Output Tuner Kit with P-1SC-1	specify	specify	-	\$5,998
specify	1FA300-F1-I	High Output Intercooled Kit with F-1D, F-1 or F-1A	specify	specify	Stage II	\$8,998
specify	1FA300-F1	High Output Kit with F-1D, F-1, or F-1A	specify	specify	-	\$7,448
specify	1FA300-F1C-I/F1R-I	High Output Intercooled Kit with F-1A-94, F-1C or F-1R	specify	specify	Stage II	\$9,348
specify	1FA300-F1C/F1R	High Output Kit with F-1A-94, F-1C or F-1R	specify	specify	-	\$7,698
specify	1FA400-F1-I	Intercooled Cog Race Kit with F-1D, F-1 or F-1A	specify	specify	Stage II	\$8,998
specify	1FA400-F1	Cog Race Kit with F-1D, F-1, or F-1A	specify	specify	-	\$7,448
specify	1FA400-F1C-I/F1R-I	Intercooled Cog Race Kit with F-1A-94, F-1C or F-1R	specify	specify	Stage II	\$9,348
specify	1FA400-F1C/F1R	Cog Race Kit with F-1A-94, F-1C or F-1R	specify	specify	-	\$7,698

COYOTE ENGINE SWAP 92-96 F-150/LIGHTNING/BRONCO (5.0 4V) KITS

Year	Part Number	Description	Boost Options	HP Gain	Intercooler	Price/MAP
specify	1FA700-P1SC1-I	High Output Intercooled Tuner Kit with P-1SC-1	specify	specify	HO	\$7,198
specify	1FA500-P1SC1	High Output Tuner Kit with P-1SC-1	specify	specify	-	\$5,998

GODZILLA ENGINE SWAP (7.3) KITS

Year	Part Number	Description	Boost Options	HP Gain	Intercooler	Price/MAP
specify	1FA600-P1SC1-I	High Output Intercooled Tuner Kit with P-1SC-1	specify	specify	HO	\$7,398
specify	1FA600-P1SC1	High Output Tuner Kit with P-1SC-1	specify	specify	-	\$6,048

Type	Part Number Suffix	Description	Upgrade From	Requirements	Notes	Price/MAP
FINISH OPTIONS	add "B" to part #	Supercharger Finish: Black, max 9.75" housing	satn	max 9.75" housing	-	+\$295
	add "P" to part #	Supercharger Finish: Polished, max 9.75" housing	satn	max 9.75" housing	-	+\$400
	add "B" to part #	Supercharger Finish: Black, 10.5" housing	satn	10.5" housing	-	+\$395
	add "P" to part #	Supercharger Finish: Polished, 10.5" housing	satn	10.5" housing	-	+\$500
	add "BB" to part #	Supercharger Bracket Finish: Black	satn	-	-	+\$225
	add "PB" to part #	Supercharger Bracket Finish: Polished	satn	-	-	+\$325
SUPER-CHARGERS	add "P1X" to part #	Supercharger Upgrade: P-1X	P-1SC-1	-	add'l 10-15+ hp	+\$250
	add "P1R" to part #	Supercharger Upgrade: P-1R	P-1SC-1	-	-	+\$600
	add "D1SC" to part #	Supercharger Upgrade: D-1SC	P-1SC-1	-	-	+\$300
	add "D1X" to part #	Supercharger Upgrade: D-1X	P-1SC-1	-	-	+\$500
	add "D" or "1" or "A"	Supercharger Upgrade: F-1D, F-1, F-1A	P-1SC-1	-	-	+\$900
	add "94" or "C" or "R"	Supercharger Upgrade: F-1A-94, F-1C or F-1R	P-1SC-1	-	-	+\$1,250
	add "103" to part #	Supercharger Upgrade: F-1R-103	P-1SC-1	-	-	+\$2,300
add "F1X" to part #	Supercharger Upgrade: F-1X	P-1SC-1	-	excludes Gen 1	+\$2,500	
KIT UPGRADES	add "H" to part #	Gears: Helical gearset for noise reduction	straight-cut	P- or D-series only	-	+\$110
	add "10R" to part #	Drive System Upgrade: 10-rib	8-rib	HO Tuner Kit only	-	+\$360
	add "RVR" or "RVB"	Blow-off Valve Upgrade: Race (specify open or closed valve; red or black)	ProFlow	-	-	+\$295
INTERCOOLERS	add "Race" to part #	Intercooler Upgrade: Air-to-Air Race	Stage II	-	3" Tubing	+\$435
SEE PAGES 94-95 FOR INTERCOOLER UPGRADE AND INTAKE MANIFOLD OPTIONS AND DIMENSIONS						
5.0L ONLY	add "CS" to part #	Coyote Crank Support, satn finish	-	Stage II only	-	+\$675
	add "BC" to part #	Crank Support Finish: Black	satn	-	-	+\$275
	add "PC" to part #	Crank Support Finish: Polished	satn	-	-	+\$300
	add "CT" to part #	Coolant Tank Reservoir Replacement Kit	-	-	-	+\$298

OPTIONS FOR THIS PAGE

COYOTE ENGINE SWAP (5.0 4V) SERPENTINE KITS - REVERSE MOUNT SPECIFICATIONS

Year	Part Number	OEM hp Rating	HP Gain	Tube Diam	Drive System	Blow-off Valve	Fuel System Upgrade	Fuel Inj. Supplied	Computer/Ignition Modifications	SC Warranty (in months)	CARB E.O.	Foot Notes
specify	1FA500-P1SC1-I	N/A	specify	3"	add'l 8-rib	ProFlow	not supplied	No	not supplied	12	-	J: 3, 5, 6, 8
specify	1FA500-P1SC1	N/A	specify	-	add'l 8-rib	ProFlow	not supplied	No	not supplied	12	-	J: 3, 5, 6, 8
specify	1FA500-F1-I	N/A	specify	3"	add'l 8-rib	Race	not supplied	No	not supplied	Limited	-	J: 1, 3, 5, 6, 8
specify	1FA500-F1	N/A	specify	-	add'l 8-rib	Race	not supplied	No	not supplied	Limited	-	J: 1, 3, 5, 6, 8
specify	1FA500-F1C-I/F1R-I	N/A	specify	3"	add'l 8-rib	Race	not supplied	No	not supplied	Limited	-	J: 1, 3, 5, 6, 8
specify	1FA500-F1C/F1R	N/A	specify	-	add'l 8-rib	Race	not supplied	No	not supplied	Limited	-	J: 1, 3, 5, 6, 8

COYOTE ENGINE SWAP (5.0 4V) SERPENTINE & COG KITS - STANDARD MOUNT SPECIFICATIONS

Year	Part Number	OEM hp Rating	HP Gain	Tube Diam	Drive System	Blow-off Valve	Fuel System Upgrade	Fuel Inj. Supplied	Computer/Ignition Modifications	SC Warranty (in months)	CARB E.O.	Foot Notes
specify	1FA400-P1SC1-I	N/A	specify	3"	add'l 8-rib	ProFlow	not supplied	No	not supplied	12	-	J: 3, 4, 8, 9
specify	1FA400-P1SC1	N/A	specify	-	add'l 8-rib	ProFlow	not supplied	No	not supplied	12	-	J: 3, 4, 8, 9
specify	1FA400-F1-I	N/A	specify	3"	add'l 8-rib	Race	not supplied	No	not supplied	Limited	-	J: 1, 3, 4, 8, 9
specify	1FA400-F1	N/A	specify	-	add'l 8-rib	Race	not supplied	No	not supplied	Limited	-	J: 1, 3, 4, 8, 9
specify	1FA400-F1C-I/F1R-I	N/A	specify	3"	add'l 8-rib	Race	not supplied	No	not supplied	Limited	-	J: 1, 3, 4, 8, 9
specify	1FA400-F1C/F1R	N/A	specify	-	add'l 8-rib	Race	not supplied	No	not supplied	Limited	-	J: 1, 3, 4, 8, 9
specify	1FA300-F1-I	N/A	specify	3"	cog	Race	not supplied	No	not supplied	Limited	-	J: 1, 3, 4, 8, 9
specify	1FA300-F1	N/A	specify	-	cog	Race	not supplied	No	not supplied	Limited	-	J: 1, 3, 4, 8, 9
specify	1FA300-F1C-I/F1R-I	N/A	specify	3"	cog	Race	not supplied	No	not supplied	Limited	-	J: 1, 3, 4, 8, 9
specify	1FA300-F1C/F1R	N/A	specify	-	cog	Race	not supplied	No	not supplied	Limited	-	J: 1, 3, 4, 8, 9

COYOTE ENGINE SWAP 92-96 F-150/LIGHTNING/BRONCO (5.0 4V) SPECIFICATIONS

Year	Part Number	OEM hp Rating	HP Gain	Tube Diam	Drive System	Blow-off Valve	Fuel System Upgrade	Fuel Inj. Supplied	Computer/Ignition Modifications	SC Warranty (in months)	CARB E.O.	Foot Notes
specify	1FA700-P1SC1-I	N/A	specify	3"	add'l 8-rib	ProFlow	not supplied	No	not supplied	12	-	J: 3, 5, 6, 8
specify	1FA500-P1SC1	N/A	specify	-	add'l 8-rib	ProFlow	not supplied	No	not supplied	12	-	J: 3, 5, 6, 8

GODZILLA ENGINE SWAP (7.3) SPECIFICATIONS

Year	Part Number	OEM hp Rating	HP Gain	Tube Diam	Drive System	Blow-off Valve	Fuel System Upgrade	Fuel Inj. Supplied	Computer/Ignition Modifications	SC Warranty (in months)	CARB E.O.	Foot Notes
specify	1FA600-P1SC1-I	N/A	specify	3"	add'l 8-rib	ProFlow	not supplied	No	not supplied	12	-	J: 7, 8
specify	1FA600-P1SC1	N/A	specify	-	add'l 8-rib	ProFlow	not supplied	No	not supplied	12	-	J: 7, 8

FORD AUTOMOTIVE FOOTNOTES (specific to above applications):

- J1) Modified engines only
- J3) Specify factory or aftermarket balancer
- J4) Requires 2011-14 Mustang accessories and utilizes 2011-14 Mustang intercooler and tubing
- J5) Reverse mount Coyote swap kits require car Gt timing cover
- J6) Requires 2015+ Mustang accessories and utilizes 2015+ Mustang intercooler and tubing
- J7) Requires Innovators West balancer #IW807
- J8) Requires engine model year
- J9) Custom crank support recommended for cog kit (sold separately by others)



2020-26 CORVETTE C8 STINGRAY COUPE (LT2) SYSTEMS AND KITS

Year	Part Number	Description	Boost Options	HP Gain	Intercooler	Price/MAP
2020-26	1KC312-SCI	Standard Profile High Output Intercooled Sytem with P-1SC-1 (satin finish)	5 psi	170 hp	Air-to-Water	\$17,998
2020-26	1KC512-SCI	Low Profile High Output Intercooled Sytem with P-1SC-1 (satin finish)	5 psi	170 hp	Air-to-Water	\$19,698
2020-26	1KC412-SCI	Standard Profile Stage II Intercooled System with P-1SC-1 (satin finish)	7.5 psi	45%+	Air-to-Water	\$18,298
2020-26	1KC612-SCI	Low Profile Stage II Intercooled System with P-1SC-1 (satin finish)	7.5 psi	45%+	Air-to-Water	\$19,998
2020-26	1KC402-SCI	Standard Profile Stage II Intercooled Tuner Kit with P-1SC-1 (satin finish)	specify	specify	Air-to-Water	\$14,998
2020-26	1KC602-SCI	Low Profile Stage II Intercooled Tuner Kit with P-1SC-1 (satin finish)	specify	specify	Air-to-Water	\$16,998

2020-26 CORVETTE C8 STINGRAY CONVERTIBLE (LT2) SYSTEMS AND KITS

Year	Part Number	Description	Boost Options	HP Gain	Intercooler	Price/MAP
2020-26	1KC512-SCI	Low Profile High Output Intercooled Sytem with P-1SC-1 (satin finish)	5 psi	170 hp	Air-to-Water	\$19,698
2020-26	1KC612-SCI	Low Profile Stage II Intercooled System with P-1SC-1 (satin finish)	7.5 psi	45%+	Air-to-Water	\$19,998
2020-26	1KC602-SCI	Low Profile Stage II Intercooled Tuner Kit with P-1SC-1 (satin finish)	specify	specify	Air-to-Water	\$16,998

NEW 2024-26 CORVETTE C8 E-RAY COUPE (HYBRID) SYSTEMS AND KITS

Year	Part Number	Description	Boost Options	HP Gain	Intercooler	Price/MAP
2024-26	1KC313-SCI	Standard Profile High Output Intercooled Sytem with P-1SC-1 (satin finish)	5 psi	170 hp	Air-to-Water	\$17,998
2024-26	1KC513-SCI	Low Profile High Output Intercooled Sytem with P-1SC-1 (satin finish)	5 psi	170 hp	Air-to-Water	\$19,698
2024-26	1KC413-SCI	Standard Profile Stage II Intercooled System with P-1SC-1 (satin finish)	7.5 psi	45%+	Air-to-Water	\$18,298
2024-26	1KC613-SCI	Low Profile Stage II Intercooled System with P-1SC-1 (satin finish)	7.5 psi	45%+	Air-to-Water	\$19,998
2024-26	1KC403-SCI	Standard Profile Stage II Intercooled Tuner Kit with P-1SC-1 (satin finish)	specify	specify	Air-to-Water	\$14,998
2024-26	1KC603-SCI	Low Profile Stage II Intercooled Tuner Kit with P-1SC-1 (satin finish)	specify	specify	Air-to-Water	\$16,998

NEW 2024-26 CORVETTE C8 E-RAY CONVERTIBLE (HYBRID) SYSTEMS AND KITS

Year	Part Number	Description	Boost Options	HP Gain	Intercooler	Price/MAP
2024-26	1KC513-SCI	Low Profile High Output Intercooled Sytem with P-1SC-1 (satin finish)	5 psi	170 hp	Air-to-Water	\$19,698
2024-26	1KC613-SCI	Low Profile Stage II Intercooled System with P-1SC-1 (satin finish)	7.5 psi	45%+	Air-to-Water	\$19,998
2024-26	1KC603-SCI	Low Profile Stage II Intercooled Tuner Kit with P-1SC-1 (satin finish)	specify	specify	Air-to-Water	\$16,998

Type	Part Number Suffix	Description	Upgrade From	Requirements	Notes	Price/MAP
FINISH OPTIONS	add "-B" to part #	Supercharger Finish: Black, max 9.75" housing	satin	max 9.75" housing	-	+\$295
	add "-P" to part #	Supercharger Finish: Polished, max 9.75" housing	satin	max 9.75" housing	-	+\$400
	add "-BB" to part #	Supercharger Bracket Finish: Black	satin	-	-	+\$225
	add "-PB" to part #	Supercharger Bracket Finish: Polished	satin	-	-	+\$325
	add "-BIM" to part #	Low Profile A/W Intake Finish: Black	raw	Low Profile only	-	+\$350
	add "-PIM" to part #	Low Profile A/W Intake Finish: Polished (lid only)	raw	Low Profile only	-	+\$500
	add "-CIM" to part #	Low Profile A/W Intake Finish: Contrast Cut	raw	Low Profile only	-	+\$450
	add "-BI" to part #	Standard Profile Intake Manifold Finish: Black	raw	Standard Profile only	-	+\$350
SUPER-CHARGERS	add "-P1X" to part #	Supercharger Upgrade: P-1X	P-1SC-1	-	add'l 10-15+ hp	+\$250
	add "-P1R" to part #	Supercharger Upgrade: P-1R	P-1SC-1	Stage II Tuner Kits only	-	+\$600
	add "-D1SC" to part #	Supercharger Upgrade: D-1SC	P-1SC-1	Stage II Tuner Kits only	-	+\$300
	add "-D1X" to part #	Supercharger Upgrade: D-1X	P-1SC-1	Stage II Tuner Kits only	-	+\$500
KIT UPGRADES	add "-H" to part #	Gears: Helical gearset for noise reduction	straight-cut	P- or D-series only	-	+\$110
	add "-INJ" to part #	Port injector bungs and fuel rails	-	Std Profile Tuner Kits only	-	+\$500

SPECIFICATIONS

2020-26 CORVETTE C8 STINGRAY COUPE (LT2) SPECIFICATIONS

Year	Part Number	OEM hp Rating	HP Gain	Tube Diam	IC Mount	Drive System	Blow-off System	Fuel System Upgrade	Fuel Inj. Supplied	Computer/Ignition Modifications	SC Warranty (in months)	CARB E.O.	Foot Notes
2020-26	1KC312-SCI	495	170 hp	3.5"	AW	stk 6-rib	not req'd	not required	no	programming supplied	12, 36 opt. (\$99)	D-365-41 (22-25)	KK: 1, 3, 4, 6, 9, 10
2020-26	1KC512-SCI	495	170 hp	3.5"	AW	stk 6-rib	not req'd	not required	no	programming supplied	12, 36 opt. (\$99)	D-365-41 (22-25)	KK: 1, 3, 4, 6, 9, 10
2020-26	1KC412-SCI	495	45%+	3.5"	AW	stk 6-rib	not req'd	not required	no	programming supplied	12, 36 opt. (\$99)	D-365-41 (22-25)	KK: 1, 3, 4, 6, 9, 10
2020-26	1KC612-SCI	495	45%+	3.5"	AW	stk 6-rib	not req'd	not required	no	programming supplied	12, 36 opt. (\$99)	D-365-41 (22-25)	KK: 3, 4, 6, 9, 10
2020-26	1KC402-SCI	495	specify	3.5"	AW	stk 6-rib	not req'd	not supplied	no	not supplied	12	-	KK: 1, 2, 3, 4, 6, 7, 8
2020-26	1KC602-SCI	495	specify	3.5"	AW	stk 6-rib	not req'd	not supplied	no	not supplied	12	-	KK: 2, 3, 4, 6, 7, 8

2020-26 CORVETTE C8 STINGRAY CONVERTIBLE (LT2) SPECIFICATIONS

Year	Part Number	OEM hp Rating	HP Gain	Tube Diam	IC Mount	Drive System	Blow-off System	Fuel System Upgrade	Fuel Inj. Supplied	Computer/Ignition Modifications	SC Warranty (in months)	CARB E.O.	Foot Notes
2020-26	1KC512-SCI	495	170 hp	3.5"	AW	stk 6-rib	not req'd	not required	no	programming supplied	12, 36 opt. (\$99)	D-365-41 (22-25)	KK: 3, 4, 6, 9, 10
2020-26	1KC612-SCI	495	45%+	3.5"	AW	stk 6-rib	not req'd	not required	no	programming supplied	12, 36 opt. (\$99)	D-365-41 (22-25)	KK: 3, 4, 6, 9, 10
2020-26	1KC602-SCI	495	specify	3.5"	AW	stk 6-rib	not req'd	not supplied	no	not supplied	12	-	KK: 2, 3, 4, 6, 7, 8

NEW 2024-26 CORVETTE C8 E-RAY COUPE (HYBRID) SPECIFICATIONS

Year	Part Number	OEM hp Rating	HP Gain	Tube Diam	IC Mount	Drive System	Blow-off System	Fuel System Upgrade	Fuel Inj. Supplied	Computer/Ignition Modifications	SC Warranty (in months)	CARB E.O.	Foot Notes
2024-26	1KC313-SCI	655	170 hp	3.5"	AW	stk 6-rib	not req'd	not required	no	programming supplied	12, 36 opt. (\$99)	-	KK: 1, 3, 4, 6, 9, 10
2024-26	1KC513-SCI	655	170 hp	3.5"	AW	stk 6-rib	not req'd	not required	no	programming supplied	12, 36 opt. (\$99)	-	KK: 1, 3, 4, 6, 9, 10
2024-26	1KC413-SCI	655	45%+	3.5"	AW	stk 6-rib	not req'd	not required	no	programming supplied	12, 36 opt. (\$99)	-	KK: 1, 3, 4, 6, 9, 10
2024-26	1KC613-SCI	655	45%+	3.5"	AW	stk 6-rib	not req'd	not required	no	programming supplied	12, 36 opt. (\$99)	-	KK: 3, 4, 6, 9, 10
2024-26	1KC403-SCI	655	specify	3.5"	AW	stk 6-rib	not req'd	not supplied	no	not supplied	12	-	KK: 1, 2, 3, 4, 6, 7, 8
2024-26	1KC603-SCI	655	specify	3.5"	AW	stk 6-rib	not req'd	not supplied	no	not supplied	12	-	KK: 2, 3, 4, 6, 7, 8

NEW 2024-26 CORVETTE C8 E-RAY CONVERTIBLE (HYBRID) SPECIFICATIONS

Year	Part Number	OEM hp Rating	HP Gain	Tube Diam	IC Mount	Drive System	Blow-off System	Fuel System Upgrade	Fuel Inj. Supplied	Computer/Ignition Modifications	SC Warranty (in months)	CARB E.O.	Foot Notes
2024-26	1KC513-SCI	655	170 hp	3.5"	AW	stk 6-rib	not req'd	not required	no	programming supplied	12, 36 opt. (\$99)	-	KK: 3, 4, 6, 9, 10
2024-26	1KC613-SCI	655	45%+	3.5"	AW	stk 6-rib	not req'd	not required	no	programming supplied	12, 36 opt. (\$99)	-	KK: 3, 4, 6, 9, 10
2024-26	1KC603-SCI	655	specify	3.5"	AW	stk 6-rib	not req'd	not supplied	no	not supplied	12	-	KK: 2, 3, 4, 6, 7, 8

CHEVROLET AUTOMOTIVE FOOTNOTES (specific to above applications):

- KK1) Does not fit convertible
- KK2) Dyno tuning is required
- KK3) Clutch upgrade and/or controller may be required
- KK4) Ships in multiple boxes; additional shipping charges apply
- KK5) Model year and VIN # must be specified
- KK6) No cutting required, trunk carpet trimming recommended
- KK7) Port Injection Option requires LS3/60mm full length injectors, no fuel injector hats
- KK8) For race use only
- KK9) Includes all hardware for a stock engine, stock exhaust car only
- KK10) PCM removal and shipment required



2014-19 CORVETTE C7 STINGRAY (LT1) AND 2017-19 GRAND SPORT (LT1) SYSTEMS AND KITS

Year	Part Number	Description	Boost Options	HP Gain	Intercooler	Price/MAP
2014-19	1GU212-SCI	High Output Intercooled System with P-1SC-1 (satin finish)	7 psi	40%+	Vertical	\$7,498
2014-19	1GU202-SCI	High Output Intercooled Tuner Kit with P-1SC-1 (satin finish)	specify	specify	Vertical	\$6,998
2014-19	1GU402-F1	Competition Race Tuner Kit with F-1D, F-1 or F-1A (satin finish)	specify	specify	1250+ hp AW	\$11,398
2014-19	1GU402-94	Competition Race Tuner Kit with F-1A-94, F-1C or F-1R (satin finish)	specify	specify	1250+ hp AW	\$11,748
2014-19	1GU502-F1	Pro Race Tuner Kit with F-1D, F-1 or F-1A (satin finish)	specify	specify	1500+ hp AW	\$12,598
2014-19	1GU502-94	Pro Race Tuner Kit with F-1A-94, F-1C or F-1R (satin finish)	specify	specify	1500+ hp AW	\$12,998

2015-19 CORVETTE C7 Z06 (LT4) KITS

Year	Part Number	Description	Boost Options	HP Gain	Intercooler	Price/MAP
2015-19	1GU204-SCI-omit	High Output Intercooled Tuner Kit with D-1SC (satin finish), no Intake Manifold	specify	specify	Vertical	\$7,698
2015-19	1GU204-SCI	High Output Intercooled Tuner Kit with D-1SC (satin finish) and Intake Manifold	specify	specify	Vertical	\$9,998
2015-19	1GU204-SCI-F1	Intercooled Race Tuner Kit with F-1D, F-1, F-1A (satin finish)	specify	specify	Vertical	\$10,498
2015-19	1GU204-SCI-94	Intercooled Race Tuner Kit with F-1A-94, F-1C, or F-1R (satin finish)	specify	specify	Vertical	\$10,989
2015-19	1GU300-F1	Competition Race Tuner Kit with F-1D, F-1, F-1A (satin finish)	specify	specify	1250+ hp AW	\$12,498
2015-19	1GU300-94	Competition Race Tuner Kit with F-1A-94, F-1C, or F-1R (satin finish)	specify	specify	1250+ hp AW	\$12,998
2015-19	1GU500-F1	Pro Race Tuner Kit with F-1D, F-1 or F-1A (satin finish)	specify	specify	1500+ hp AW	\$13,598
2015-19	1GU500-94	Pro Race Tuner Kit with F-1A-94, F-1C or F-1R (satin finish)	specify	specify	1500+ hp AW	\$13,948

Applications	Part Number Suffix	Description	Upgrade From	Requirements	Notes	Price/MAP	
ALL	add "-B" to part #	Supercharger Finish: Black, max 9.75" housing	satin	max 9.75" housing	-	+\$295	
	add "-P" to part #	Supercharger Finish: Polished, max 9.75" housing	satin	max 9.75" housing	-	+\$400	
	add "-B" to part #	Supercharger Finish: Black, 10.5" housing	satin	10.5" housing	-	+\$395	
	add "-P" to part #	Supercharger Finish: Polished, 10.5" housing	satin	10.5" housing	-	+\$500	
	add "-BB" to part #	Supercharger Bracket Finish: Black	satin	-	-	+\$225	
	add "-PB" to part #	Supercharger Bracket Finish: Polished	satin	-	-	+\$325	
	add "-BIC" to part #	Intake Manifold Finish: Black	raw	-	-	+\$225	
	add "-BC" to part #	Intake Manifold Cover Finish: Black	raw	-	-	+\$35	
	add "-H" to part #	Gears: Helical gearset for noise reduction	straight-cut	P- or D-series only	-	+\$110	
	add "-10R" to part #	10-rib drive system upgrade	8-rib	-	-	+\$360	
add "-CP" to part #	8.80" Crank Pulley Upgrade	-	10-rib only	-	+\$120		
LT1 ONLY	add "-P1X" to part #	Supercharger Upgrade: P-1X	P-1SC-1	-	add'l 10-15+ hp	+\$250	
	add "-P1R" to part #	Supercharger Upgrade: P-1R	P-1SC-1	-	-	+\$600	
	add "-D1SC" to part #	Supercharger Upgrade: D-1SC	P-1SC-1	Tuner Kits only	-	+\$300	
	add "-D1X" to part #	Supercharger Upgrade: D-1X	P-1SC-1	Tuner Kits only	-	+\$500	
	add "-D" or "-1" or "-A"	Supercharger Upgrade: F-1D, F-1, F-1A	P-1SC-1	Tuner Kits only	-	+\$900	
	add "-94" or "-C" or "-R"	Supercharger Upgrade: F-1A-94, F-1C or F-1R	P-1SC-1	Tuner Kits only	-	+\$1,250	
	add "-103" to part #	Supercharger Upgrade: F-1R-103	P-1SC-1	Tuner Kits only	-	+\$2,300	
	add "-F1X" to part #	Supercharger Upgrade: F-1X	P-1SC-1	Tuner Kits only	-	+\$2,500	
	add "-F1X" to part #	Supercharger Upgrade: F-1X	F-1A-94, F-1C or F-1R	Tuner Kits only	-	+\$1,250	
	add "-BV" to part #	Bullet Blow-off Valve Upgrade (black only)	ProFlow	-	-	+\$125	
	add "-RVR" or "RVB"	Race Blow-off Valve Upgrade, open only (specify alum or steel, red or blk)	ProFlow	open only	-	+\$295	
	3FASS-00X	Race Blow-off Valve, open only (specify alum or steel, red or black)	-	Race Kit, open only	-	+\$498	
	add "-ATIPP" to part #	ATI Performance Products Balancer Upgrade	-	-	-	+\$550	
	add "-AB" to part #	Factory Air Box Inlet and Filter	Race	-	7 psi max	+\$215	
add "-INT" to part #	Sheet Metal Aluminum Intake Manifold and Cover	raw	Tuner Kits only	-	+\$2,498		
add "-INT/INJ" to part #	Sheet Metal Aluminum Intake Manifold and Cover w/ injector bungs and fuel rails	raw	Tuner Kits only	-	+\$2,998		
LT4 ONLY	add "-D1X" to part #	Supercharger Upgrade: D-1X	D-1SC	-	-	+\$200	
	add "-103" to part #	Supercharger Upgrade: F-1R-103	F-1A-94, F-1C or F-1R	-	-	+\$1,050	
	add "-F1X" to part #	Supercharger Upgrade: F-1X	F-1A-94, F-1C or F-1R	-	-	+\$1,250	
	add "-omit" to part #	Omit Intake Manifold	-	-	-	-\$2,298	
	add "-RVR" or "RVB"	Race Blow-off Valve Upgrade (specify open or closed, alum or steel, red or blk)	Bullet	-	-	+\$170	
add "-INT/INJ" to part #	Upgrade intake manifold for use with port injection	raw	-	-	+\$500		
i-1 ONLY	SEE PAGE 88 FOR i-1 OPTIONS						

SPECIFICATIONS

2014-19 CORVETTE C7 STINGRAY (LT1) AND 2017-19 GRAND SPORT (LT1) SPECIFICATIONS

Year	Part Number	OEM hp Rating	HP Gain	Tube Diam	IC Mount	Drive System	Blow-off System	Fuel System Upgrade	Fuel Inj. Supplied	Computer/Ignition Modifications	SC Warranty (in months)	CARB E.O.	Foot Notes
2014-19	1GU212-SCI	455	40%+	3"	V	add'l 8-rib	ProFlow	not required	not required	programmer supplied	12, 36 opt. (\$99)	D-365-17	K: 1, 2, 3, 6, 7, 8, 10
2014-19	1GU202-SCI	455	specify	3"	V	add'l 8-rib	ProFlow	not supplied	no	not supplied	12	-	K: 1, 2, 3, 6, 7, 8, 9, 10, 11, 13
2014-19	1GU402-F1	455	specify	3"	V	add'l 8-rib	Race	not supplied	no	not supplied	12	-	K: 1, 2, 3, 6, 7, 8, 9, 10, 11, 13
2014-19	1GU402-94	455	specify	3"	V	add'l 8-rib	Race	not supplied	no	not supplied	12	-	K: 1, 2, 3, 6, 7, 8, 9, 10, 11, 13
2014-19	1GU502-F1	455	specify	3"	V	add'l 10-rib	Race	not supplied	no	not supplied	12	-	K: 1, 2, 3, 6, 7, 8, 9, 10, 11, 12, 13
2014-19	1GU502-94	455	specify	3"	V	add'l 10-rib	Race	not supplied	no	not supplied	12	-	K: 1, 2, 3, 6, 7, 8, 9, 10, 11, 12, 13

2015-19 CORVETTE C7 Z06 (LT4) SPECIFICATIONS

Year	Part Number	OEM hp Rating	HP Gain	Tube Diam	IC Mount	Drive System	Blow-off System	Fuel System Upgrade	Fuel Inj. Supplied	Computer/Ignition Modifications	SC Warranty (in months)	CARB E.O.	Foot Notes
2015-19	1GU204-SCI	650	specify	3"	V	add'l 8-rib	Bullet	not required	not required	not supplied	12	-	K: 1, 2, 6, 10, 11, 13
2015-19	1GU204-SCI	650	specify	3"	V	add'l 8-rib	Bullet	not required	not required	not supplied	12	-	K: 1, 2, 6, 10, 11, 13
2015-19	1GU204-SCI-F1	650	specify	3"	V	add'l 8-rib	Race	not supplied	no	not supplied	12	-	K: 1, 2, 6, 10, 11, 13
2015-19	1GU204-SCI-94	650	specify	3"	V	add'l 8-rib	Race	not supplied	no	not supplied	12	-	K: 1, 2, 6, 9, 10, 11, 13
2015-19	1GU300-F1	650	specify	3"	A/W	add'l 8-rib	Race	not supplied	no	not supplied	12	-	K: 1, 2, 6, 10, 11, 13
2015-19	1GU300-94	650	specify	3"	A/W	add'l 8-rib	Race	not supplied	no	not supplied	12	-	K: 1, 2, 6, 9, 10, 11, 13
2015-19	1GU500-F1	650	specify	3"	A/W	add'l 10-rib	Race	not supplied	no	not supplied	12	-	K: 1, 2, 6, 10, 11, 12, 13
2015-19	1GU500-94	650	specify	3"	A/W	add'l 10-rib	Race	not supplied	no	not supplied	12	-	K: 1, 2, 6, 9, 10, 11, 12, 13

2014-17 CORVETTE C7 STINGRAY (LT1) i-1 SPECIFICATIONS

Year	Part Number	OEM hp Rating	HP Gain	Tube Diam	IC Mount	Drive System	Blow-off System	Fuel System Upgrade	Fuel Inj. Supplied	Computer/Ignition Modifications	SC Warranty (in months)	CARB E.O.	Foot Notes
2014-17	1GU312-SCI	455	45%+	3"	V	add'l 8-rib	ProFlow	not required	not required	programmer supplied	12, 36 opt. (\$599)	-	K: 1, 2, 3, 4, 7, 8, 10, 14

CHEVROLET AUTOMOTIVE FOOTNOTES (specific to above applications):

- K1) Model year and manual or automatic transmission must be specified
- K2) Satin finish is now standard for Corvette systems; polished finish and black finish is optional
- K3) Specify wet or dry oil sump
- K4) Due to variability among OEM computers, the prevalence of custom modifications, and age/miles/condition of vehicles, dyno tuning may be required
- K6) Specify stock or aftermarket balancer (ATI Balancer Part Numbers: LT1 Dry #917315, LT1 Wet #917314, Z06 LT4 #917315; specify hardend hub)
- K7) Vertical intercooler recommended for drag racing use
- K8) Horizontal intercooler only available for 2014 Corvette C7's (LT1)
- K9) F-1X, F-1R-103 supercharger upgrade requires modifications
- K10) Two-part shipment, additional shipping charges may apply
- K11) Works with maximum of 10% overdrive crank pulley
- K12) Ice-tank may require modifications and trimming
- K13) Port injection Option requires LS3/38mm length injectors
- K14) Special order kit: order form and non-refundable deposit required at time of order—may require additional lead time for processing



2008-13 CORVETTE C6 (LS3) SYSTEMS AND KITS

Year	Part Number	Description	Boost Options	HP Gain	Intercooler	Price/MAP
2008-13 (LS3)	1GQ212-SCI	High Output Intercooled System with P-1SC-1 (satin finish)	7 psi	45-50%+	C6 3 Core	\$7,998
2008-13 (LS3)	1GQ202-SCI	High Output Intercooled Tuner Kit with P-1SC-1 (satin finish)	specify	specify	C6 3 Core	\$7,098
2008-13 (LS3)	1GQ314-SCI	Stage II Intercooled System with P-1SC-1 (satin finish)	7 psi	45-50%+	C6 3 core	\$8,648
2008-13 (LS3)	1GQ304-SCI	Stage II Intercooled Tuner Kit with P-1SC-1 (satin finish)	specify	specify	C6 3 core	\$7,848
2008-13 (LS3)	1GQ402-SCI	Intercooled Race Kit with F-1D, F-1 or F-1A (satin finish)	specify	specify	Race	\$9,198
2008-13 (LS3)	1GQ402-SCI-94	Intercooled Race Kit with F-1A-94, F-1C or F-1R (satin finish)	specify	specify	Race	\$9,548

2006-13 CORVETTE C6 Z06 (LS7) SYSTEMS AND KITS

Year	Part Number	Description	Boost Options	HP Gain	Intercooler	Price/MAP
2006-13 (LS7)	1GP214-SCI	High Output Intercooled System with P-1SC-1 (satin finish)	4.5 psi	40%+	C6 3 core	\$8,098
2006-13 (LS7)	1GP204-SCI	High Output Intercooled Tuner Kit with P-1SC-1 (satin finish)	specify	specify	C6 3 core	\$7,198
2006-13 (LS7)	1GP314-SCI	Stage II Intercooled System with P-1SC-1 (satin finish)	4.5 psi	40%+	C6 3 core	\$8,898
2006-13 (LS7)	1GP304-SCI	Stage II Intercooled Tuner Kit with P-1SC-1 (satin finish)	specify	specify	C6 3 core	\$8,048
2006-13 (LS7)	1GP404-SCI	Intercooled Race Kit with F-1D, F-1 or F-1A (satin finish)	specify	specify	Race	\$9,398
2006-13 (LS7)	1GP404-SCI-94	Intercooled Race Kit with F-1A-94, F-1C or F-1R (satin finish)	specify	specify	Race	\$9,748

2005-07 CORVETTE C6 (LS2) SYSTEMS AND KITS

Year	Part Number	Description	Boost Options	HP Gain	Intercooler	Price/MAP
2005-07	1GP202-SCI	High Output Intercooled System with P-1SC-1 (satin finish)	6 psi	50%+	C6 3 core	\$7,998
2005-07	1GP212-SCI	High Output Intercooled Tuner Kit with P-1SC-1 (satin finish)	specify	specify	C6 3 core	\$7,098
2005-07	1GP315-SCI	Stage II Intercooled System with P-1SC-1 (satin finish)	6 psi	50%+	C6 3 core	\$8,648
2005-07	1GP305-SCI	Stage II Intercooled Tuner Kit with P-1SC-1 (satin finish)	specify	specify	C6 3 core	\$7,848
2005-07	1GP402-SCI	Intercooled Race Kit with F-1D, F-1 or F-1A (satin finish)	specify	specify	Race	\$9,198
2005-07	1GP402-SCI-94	Intercooled Race Kit with F-1A-94, F-1C or F-1R (satin finish)	specify	specify	Race	\$9,548

Type	Part Number Suffix	Description	Upgrade From	Requirements	Notes	Price/MAP
FINISH OPTIONS	add "B" to part #	Supercharger and Bracket Finish: Black, max 9.75" housing	satin	max 9.75" housing	-	+\$550
	add "P" to part #	Supercharger and Bracket Finish: Polished, max 9.75" housing	satin	max 9.75" housing	-	+\$750
	add "B" to part #	Supercharger and Bracket Finish: Black, 10.5" housing	satin	10.5" housing	-	+\$650
	add "P" to part #	Supercharger and Bracket Finish: Polished, 10.5" housing	satin	10.5" housing	-	+\$850
SUPER-CHARGERS	add "P1X" to part #	Supercharger Upgrade: P-1X	P-1SC-1	non-EO kit	add'l 10-15+ hp	+\$250
	add "P1R" to part #	Supercharger Upgrade: P-1R	P-1SC-1	Tuner Kits only	-	+\$600
	add "D1SC" to part #	Supercharger Upgrade: D-1SC	P-1SC-1	Tuner Kits only	-	+\$300
	add "D1X" to part #	Supercharger Upgrade: D-1X	P-1SC-1	Tuner Kits only	-	+\$500
	add "D" or "1" or "A"	Supercharger Upgrade: F-1D, F-1, F-1A	P-1SC-1	Stage II Tuner Kits only	8-rib required	+\$900
	add "94" or "C" or "R"	Supercharger Upgrade: F-1A-94, F-1C or F-1R	P-1SC-1	Stage II Tuner Kits only	-	+\$1,250
	add "103" to part #	Supercharger Upgrade: F-1R-103	P-1SC-1	Tuner Kits only	-	+\$2,300
add "F1X" to part #	Supercharger Upgrade: F-1X	F-1A-94, F-1C or F-1R	Race Kit only	-	+\$1,250	
KIT UPGRADES	add "H" to part #	Gears: Helical gearset for noise reduction	straight-cut	P- or D-series only	-	+\$110
	add "8R" to part #	8-rib dedicated drive upgrade (time of purchase)	6-rib	Stage II only	-	+\$360
	add "WP" to part #	With Modified Water Pump for LS3/LS7	-	-	-	+\$165
	add "Race" to part #	Intercooler Upgrade: Race air-to-air, 1300 HP max	3-core	HO, Stage II only	-	+\$435
	add "RVR" or "RVB"	Race Blow-off Valve Upgrade (specify open or closed, alum or steel, red or blk)	ProFlow	-	included in Race Kits	+\$295
i-1 ONLY	SEE PAGE 88 FOR i-1 OPTIONS					

2008-13 CORVETTE C6 (LS3) i-1 PROGRAMMABLE RATIO SYSTEMS

Year	Part Number	Description	Boost Options	HP Gain	Std Intercooler	Price/MAP
2008-13 (LS3)	1GQ312-SCI	High Output Intercooled System with i-1 (satin finish)	7 psi	50%+	C6 3 core	\$13,498

SPECIFICATIONS

2008-13 CORVETTE C6 (LS3) SPECIFICATIONS

Year	Part Number	OEM hp Rating	HP Gain	Tube Diam	IC Mount	Drive System	Blow-off System	Fuel System Upgrade	Fuel Inj. Supplied	Computer/Ignition Modifications	SC Warranty (in months)	CARB E.O.	Foot Notes
2008-13	1GQ212-SCI	430	45-50%+	3"	V	stk 6-rib	ProFlow	not required	50 lb/hr	programmer sup.	12, 36 opt. (\$99)	-	L: 1, 2, 3, 4, 6, 9, 10, 11, 12
2008-13	1GQ202-SCI	430	specify	3"	V	stk 6-rib	ProFlow	not supplied	no	not supplied	12	-	L: 1, 2, 3, 6, 9, 10, 11, 12
2008-13	1GQ314-SCI	430	45-50%+	3"	V	add'l 6-rib	ProFlow	not required	50 lb/hr	programmer sup.	12, 36 opt. (\$99)	-	L: 1, 2, 3, 4, 5, 6, 9, 10, 11, 12
2008-13	1GQ304-SCI	430	specify	3"	V	add'l 6-rib	ProFlow	not supplied	no	not supplied	12	-	L: 1, 2, 3, 5, 6, 9, 10, 11, 12
2008-13	1GQ402-SCI	430	specify	4"	V	add'l 10-rib	Race	not supplied	no	not supplied	-	-	L: 1, 2, 3, 7, 9, 10, 11, 12
2008-13	1GQ402-F1C-SCI	430	specify	4"	V	add'l 10-rib	Race	not supplied	no	not supplied	-	-	L: 1, 2, 3, 6, 7, 9, 10, 11, 12

2006-13 CORVETTE C6 Z06 (LS7) SPECIFICATIONS

Year	Part Number	OEM hp Rating	HP Gain	Tube Diam	IC Mount	Drive System	Blow-off System	Fuel System Upgrade	Fuel Inj. Supplied	Computer/Ignition Modifications	SC Warranty (in months)	CARB E.O.	Foot Notes
2006-13	1GP214-SCI	505	40%+	3"3.5"	V	stk 6-rib	ProFlow	not required	65 lb/hr	programmer sup.	12, 36 opt. (\$99)	-	L: 1, 2, 4, 6, 10, 11, 12
2006-13	1GP204-SCI	505	specify	3"3.5"	V	stk 6-rib	ProFlow	not supplied	No	not supplied	12	-	L: 1, 2, 6, 10, 11, 12
2006-13	1GP314-SCI	505	40%+	3"3.5"	V	add'l 6-rib	ProFlow	not required	65 lb/hr	programmer sup.	12, 36 opt. (\$99)	-	L: 1, 2, 4, 5, 6, 10, 11, 12
2006-13	1GP304-SCI	505	specify	3"3.5"	V	add'l 6-rib	ProFlow	not supplied	No	not supplied	12	-	L: 1, 2, 5, 6, 10, 11, 12
2006-13	1GP404-SCI	505	specify	4"	V	add'l 10-rib	Race	not supplied	No	not supplied	-	-	L: 1, 2, 6, 7, 10, 11, 12
2006-13	1GP404-F1C-SCI	505	specify	4"	V	add'l 10-rib	Race	not supplied	No	not supplied	-	-	L: 1, 2, 6, 7, 10, 11, 12

2005-07 CORVETTE C6 (LS2) SPECIFICATIONS

Year	Part Number	OEM hp Rating	HP Gain	Tube Diam	IC Mount	Drive System	Blow-off System	Fuel System Upgrade	Fuel Inj. Supplied	Computer/Ignition Modifications	SC Warranty (in months)	CARB E.O.	Foot Notes
2005-07	1GP202-SCI	400	50%+	3"3.5"	V	stk 6-rib	ProFlow	not required	57 lb/hr	programmer sup.	12, 36 opt. (\$99)	D-365-6 (05)	L: 1, 2, 3, 10, 11, 12
2005-07	1GP212-SCI	400	specify	3"3.5"	V	stk 6-rib	ProFlow	not supplied	No	not supplied	12	-	L: 1, 2, 3, 10, 11, 12
2005-07	1GP315-SCI	400	50%+	3"3.5"	V	add'l 6-rib	ProFlow	not required	57 lb/hr	programmer sup.	12, 36 opt. (\$99)	-	L: 1, 2, 3, 4, 5, 10, 11, 12
2005-07	1GP305-SCI	400	specify	3"3.5"	V	add'l 6-rib	ProFlow	not supplied	No	not supplied	12	-	L: 1, 2, 3, 5, 10, 11, 12
2005-07	1GP402-SCI	400	specify	4"	V	add'l 10-rib	Race	not supplied	No	not supplied	-	-	L: 1, 2, 3, 7, 10, 11, 12
2005-07	1GP402-F1C-SCI	400	specify	4"	V	add'l 10-rib	Race	not supplied	No	not supplied	-	-	L: 1, 2, 3, 7, 10, 11, 12

2008-13 CORVETTE C6 (LS3) i-1 SPECIFICATIONS

Year	Part Number	OEM hp Rating	HP Gain	Tube Diam	IC Mount	Drive System	Blow-off System	Fuel System Upgrade	Fuel Inj. Supplied	Computer/Ignition Modifications	SC Warranty (in months)	CARB E.O.	Foot Notes
2008-13	1GQ312-SCI	430	50%+	3"	V	stk 6-rib	ProFlow	pump voltage booster	50 lb/hr	programmer sup.	12, 36 opt. (\$599)	-	L: 1, 2, 3, 4, 9, 11, 12, 13

CHEVROLET AUTOMOTIVE FOOTNOTES (specific to above applications):

- L1) Model year and manual or automatic transmission must be specified
- L2) Satin finish is now standard for Corvette systems; polished finish and black finish are optional
- L3) Specify wet or dry oil sump
- L4) Due to variability among OEM computers, the prevalence of custom modifications, and age/miles/condition of vehicles, dyno tuning may be required
- L5) 8-rib upgrade requires ATI PP balancer #917345 (LS3/LS2, wet sump) or #918620 (LS7/GS, dry sump) or Innovator's West #843 (LS3/LS2, wet sump) or #853 (LS7/GS, dry sump) - not included, specify hardened hub
- L6) 2009-13 models require water pump modification (water pump available from ProCharger)
- L7) Requires 10-rib ATI PP balancer #917347X (LS3/LS2, wet sump) (not supplied), or Innovator's West balancer #844 (LS3/LS2, wet sump) or #854 (LS7/GS, dry sump) - not included, specify hardened hub
- L9) Grand Sport Corvette applications must be noted at time of order, including body style
- L10) Race intercooler option requires oil cooler relocation (not supplied)
- L11) Specify stock or aftermarket balancer
- L12) Two-part shipment, additional shipping charges may apply
- L13) Special order kit: order form and non-refundable deposit required at time of order—may require additional lead time for processing
- L14) Race Kits include modified water pump

1997-04 CORVETTE C5 (LS1) SYSTEMS AND KITS

Year	Part Number	Description	Boost Options	HP Gain	Intercooler	Price/MAP
1999-04 (LS1)	1GK213-SCI	High Output Intercooled System with P-1SC-1 (satin finish, shared 6-rib)	7 psi	55%+	4.5" twin highflow	\$8,148
1997-04 (LS1)	1GK203-SCI	High Output Intercooled Tuner Kit with P-1SC-1 (satin finish, shared 6-rib)	specify	specify	4.5" twin highflow	\$6,998
1999-04 (LS1)	1GK414-SCI	Stage II Intercooled System with P-1SC-1 (satin finish)	7 psi	55%+	4.5" twin highflow	\$8,798
1997-04 (LS1)	1GK404-SCI	Stage II Intercooled Tuner Kit with P-1SC-1 (satin finish)	specify	specify	4.5" twin highflow	\$7,748

2001-04 CORVETTE C5 Z06 (LS6) SYSTEMS AND KITS

Year	Part Number	Description	Boost Options	HP Gain	Intercooler	Price/MAP
2001-04 (LS6)	1GK216-SCI	High Output Intercooled System with P-1SC-1 (satin finish, shared 6-rib)	6 psi	50%+	4.5" twin highflow	\$8,298
2001-04 (LS6)	1GK206-SCI	High Output Intercooled Tuner Kit with P-1SC-1 (satin finish, shared 6-rib)	specify	specify	4.5" twin highflow	\$7,148
2001-04 (LS6)	1GK219-SCI	Stage II Intercooled System with P-1SC-1 (satin finish)	6 psi	50%+	4.5" twin highflow	\$8,898
2001-04 (LS6)	1GK209-SCI	Stage II Intercooled Tuner Kit with P-1SC-1 (satin finish)	specify	specify	4.5" twin highflow	\$7,748

1992-96 CORVETTE C4 (LT1, LT4) SYSTEMS AND KITS

Year	Part Number	Description	Boost Options	HP Gain	Intercooler	Price/MAP
1992-96 (LT1)	1GF211-SCI	High Output Intercooled System with P-1SC (satin finish)	8 psi	55-60%	LT1 Vette 2 core	\$7,298
1992-96 (LT1)	1GF201-SCI	High Output Intercooled Tuner Kit with P-1SC (satin finish)	specify	specify	LT1 Vette 2 core	\$6,998
1996 (LT4)	1GF212-SCI	High Output Intercooled System with P-1SC (satin finish)	6 psi	45-50%	LT1 Vette 2 core	\$7,298
1996 (LT4)	1GF202-SCI	High Output Intercooled Tuner Kit with P-1SC (satin finish)	specify	specify	LT1 Vette 2 core	\$6,998

1985-91 CORVETTE C4 TPI (L98) SYSTEMS AND KITS

Year	Part Number	Description	Boost Options	HP Gain	Intercooler	Price/MAP
1985-91 (L98)	1GB212-08I	High Output Intercooled System with P600B (satin finish)	8 psi	55-75%	2 core (85-89) Twin (90-91)	\$6,998
1985-91 (L98)	1GB211-06S	High Output Kit with P600B (satin finish)	specify	specify	-	\$5,898
1985-91 (L98)	1GB212-D1	High Output Intercooled System with D-1 (satin finish)	10+ psi	75%+	2 core (85-89) Twin (90-91)	\$7,498
1985-91 (L98)	1GB211-D1	High Output Tuner Kit with D-1 (satin finish)	specify	specify	-	\$6,398

Applications	Part Number Suffix	Description	Upgrade From	Requirements	Notes	Price/MAP
LS1 & LS6 ONLY	add "B" to part #	Supercharger and Bracket Finish: Black, max 9.75" housing	satin	max 9.75" housing	-	+\$550
	add "P" to part #	Supercharger and Bracket Finish: Polished, max 9.75" housing	satin	max 9.75" housing	-	+\$750
	add "B" to part #	Supercharger and Bracket Finish: Black, 10.5" housing	satin	10.5" housing	-	+\$650
	add "P" to part #	Supercharger and Bracket Finish: Polished, 10.5" housing	satin	10.5" housing	-	+\$850
	add "H" to part #	Gears: Helical gears for noise reduction	straight-cut	P- or D-series only	-	+\$110
	add "D1SC" to part #	Supercharger Upgrade: D-1SC	P-1SC-1	Tuner Kits only	-	+\$300
	add "P1X" to part #	Supercharger Upgrade: P-1X	P-1SC-1	Stage II only	add'l 10-15+ hp	+\$250
	add "P1R" to part #	Supercharger Upgrade: P-1R	P-1SC-1	Stage II only	add'l 10-15+ hp	+\$600
	add "D1X" to part #	Supercharger Upgrade: D-1X	P-1SC-1	Stage II Tuner Kits only	-	+\$500
	add "D" or "1" or "A"	Supercharger Upgrade: F-1D, F-1, F-1A	P-1SC-1	Stage II Tuner Kits only	8-rib required	+\$900
	add "94" to part #	Supercharger Upgrade: F-1A-94	P-1SC-1	Stage II Tuner Kits only	8-rib required	+\$1,250
	add "103" to part #	Supercharger Upgrade: F-1R-103	P-1SC-1	Tuner Kits only	-	+\$2,300
	add "8R" to part #	8-rib dedicated drive upgrade (time of purchase)	6-rib	Stage II only	-	+\$360
	add "RVR" or "RVB"	Race Blow-off Valve Upgrade (specify open or closed, alum or steel, red or blk)	ProFlow	Stage II only	-	+\$295
LT1, LT4 ONLY	add "P" to part #	Supercharger and Bracket Finish: Polished	satin	-	-	+\$700
	add "H" to part #	Gears: Helical gears for noise reduction	straight-cut	P- or D-series only	-	+\$110
	add "D1SC" to part #	Supercharger Upgrade: D-1SC	P-1SC	-	-	+\$525
L98 ONLY	MA001I-001	Mass Airflow Massager	-	1996 only	-	+\$249
	add "P" to part #	Supercharger and Bracket Finish: Polished	satin	-	-	+\$700
	add "OF" to part #	Omit FMU	-	Stage II only	-	-\$88
	add "OP" to part #	Omit in-line fuel pump	-	D-1 system only	-	-\$98

SPECIFICATIONS

1997-04 CORVETTE C5 (LS1) SPECIFICATIONS

Year	Part Number	OEM hp Rating	HP Gain	Tube Diam	IC Mount	Drive System	Blow-off System	Fuel System Upgrade	Fuel Inj. Supplied	Computer/Ignition Modifications	Supercharger Warranty (in months)	CARB E.O.	Foot Notes
1999-04	1GK213-SCI	345	55%+	3" ea	Twin	stk 6-rib	ProFlow	not required	38 lb/hr	programmer sup.	12, 36 opt. (\$99)	D-365-6	M: 1, 2, 4
1999-04	1GK203-SCI	345	specify	3" ea	Twin	stk 6-rib	ProFlow	not supplied	No	not supplied	12	-	M: 1, 2, 4
1999-04	1GK414-SCI	345	55%+	3" ea	Twin	add'l 6-rib	ProFlow	not supplied	38 lb/hr	programmer sup.	12	-	M: 1, 2, 3, 4
1999-04	1GK404-SCI	345	specify	3" ea	Twin	add'l 6-rib	ProFlow	not supplied	No	not supplied	12	-	M: 1, 2, 4

2001-04 CORVETTE C5 Z06 (LS6) SPECIFICATIONS

Year	Part Number	OEM hp Rating	HP Gain	Tube Diam	IC Mount	Drive System	Blow-off System	Fuel System Upgrade	Fuel Inj. Supplied	Computer/Ignition Modifications	Supercharger Warranty (in months)	CARB E.O.	Foot Notes
2001-04	1GK216-SCI	405	50%+	3" ea	Twin	stk 6-rib	ProFlow	not required	38 lb/hr	programmer sup.	12, 36 opt. (\$99)	D-365-6	M: 1, 2, 4
2001-04	1GK206-SCI	405	specify	3" ea	Twin	stk 6-rib	ProFlow	not supplied	No	not supplied	12	-	M: 1, 2, 4
2001-04	1GK219-SCI	405	50%+	3" ea	Twin	add'l 6-rib	ProFlow	not supplied	38 lb/hr	programmer sup.	12	-	M: 1, 2, 3, 4
2001-04	1GK209-SCI	405	specify	3" ea	Twin	add'l 6-rib	ProFlow	not supplied	No	not supplied	12	-	M: 1, 2, 4

1992-96 CORVETTE C4 (LT1, LT4) SPECIFICATIONS

Year	Part Number	OEM hp Rating	HP Gain	Tube Diam	IC Mount	Drive System	Blow-off System	Fuel System Upgrade	Fuel Inj. Supplied	Computer/Ignition Modifications	Supercharger Warranty (in months)	CARB E.O.	Foot Notes
1992-96	1GF211-071 / 09I	300	55-60%	3"	V	stk 6-rib	Bosch	ProPump, FMU	not req.	not required	12, 36 opt. (\$99)	D-365-3 (92-95)	M: 1, 2, 7, 11, 12
1992-96	1GF201-SCI	300	specify	3"	V	stk 6-rib	Bosch	not supplied	No	not supplied	12	-	M: 1, 2, 7, 11, 12
1996	1GF212-SCI	330	45-50%	3"	V	stk 6-rib	Bosch	ProPump, FMU	not req.	not required	12, 36 opt. (\$99)	-	M: 1, 2, 3, 7, 11, 12
1996	1GF202-SCI	330	specify	3"	V	stk 6-rib	Bosch	not supplied	No	not supplied	12	-	M: 1, 2, 8, 11, 12

1985-91 CORVETTE C4 TPI (L98) SPECIFICATIONS

Year	Part Number	OEM hp Rating	HP Gain	Tube Diam	IC Mount	Drive System	Blow-off System	Fuel System Upgrade	Fuel Inj. Supplied	Computer/Ignition Modifications	Supercharger Warranty (in months)	CARB E.O.	Foot Notes
1985-91	1GB212-08I	230-250	55-75%	2.5"	V or Twin	stk 6-rib	Bosch	ProPump, FMU	not req.	not required	36	D-365-3	M: 1, 2, 9 (12 psi), 10, 11, 13
1985-91	1GB211-06S	230-250	specify	3"	-	stk 6-rib	not required	not supplied	No	not required	36	-	M: 1, 2, 10, 11, 13
1985-91	1GB212-D1	230-250	75%+	2.5"	V or Twin	stk 6-rib	Bosch	ProPump, FMU	No	not required	12	-	M: 1, 2, 3, 9 (12 psi), 10, 11, 13
1985-91	1GB211-D1	230-250	specify	3"	-	stk 6-rib	not supplied	-	No	not required	12	-	M: 1, 2, 8, 10, 11, 13

CHEVROLET AUTOMOTIVE FOOTNOTES (specific to above applications):

- M1) Model year and manual or automatic transmission must be specified
- M2) Satin finish is now standard for Corvette systems; black or polished finish are optional
- M3) Due to variability among OEM computers, the prevalence of custom modifications, and age/miles/condition of vehicles, dyno tuning may be required
- M4) 8-rib drive system upgrade is available for 1997-04 LS1/LS6 Stage II Systems/Tuner Kits and requires ATI PP balancer #917345 - not supplied
- M7) Mass airflow massager required for 1996 LT1's (sold separately by ProCharger)
- M8) Modified engines only
- M9) Larger fuel injectors may be required (sold separately by others)
- M10) Some GM suspension options may require slight modification to hood reinforcement or supercharger bracket
- M11) Special order kit: order form and non-refundable deposit required at time of order—may require additional lead time for processing
- M12) A/C line may need to be modified or removed
- M13) Does not work with magnetic ride control



2016-24 CAMARO SS (LT1) SYSTEMS AND KITS

Year	Part Number	Description	Boost Options	HP Gain	Intercooler	Price/MAP
2016-24	1GY211-SCI	Intercooled System with Factory Airbox and P-1SC-1 only	7 psi	150+ hp	3 core	\$8,198
2016-24	"add SII"	Stage II Intercooler Option for Factory Airbox System P-1SC-1 only	7 psi	Add'l 20+ hp	From 3 core	+400
2016-24	1GY201-SCI	Intercooled Tuner Kit with Factory Airbox	specify	specify	3 core	\$7,848
2016-24	1GY212-SCI	High Output Intercooled System with P-1SC-1	7 psi	150+ hp	3 core	\$8,098
2016-24	1GY202-SCI	High Output Intercooled Tuner Kit with P-1SC-1	specify	specify	3 core	\$7,748
2016-24	1GY312-SCI	Stage II Intercooled System with P-1SC-1	7 psi	170+ hp	Stage II	\$8,498
2016-24	1GY302-SCI	Stage II Intercooled Tuner Kit with P-1SC-1	specify	specify	Stage II	\$8,148
2016-24	1GY402-F1	Competition Race Tuner Kit with F-1D, F-1 or F-1A	specify	specify	1250+ hp AW	\$11,648
2016-24	1GY402-SCI-94	Competition Race Tuner Kit with F-1A-94, F-1C or F-1R	specify	specify	1250+ hp AW	\$11,998

2017-21 CAMARO ZL1 (LT4) KITS

Year	Part Number	Description	Boost Options	HP Gain	Intercooler	Price/MAP
2017-21	1GY204-SCI	Stage II Intercooled Tuner Kit with D-1SC, no Intake Manifold	specify	specify	Stage II	\$7,998
2017-21	1GY204-SCI	Stage II Intercooled Tuner Kit with D-1SC and Intake Manifold	specify	specify	Stage II	\$9,998
2017-21	1GY404-F1	Intercooled Race Tuner Kit with F-1D, F-1 or F-1A	specify	specify	Race	\$10,598
2017-21	1GY404-SCI-94	Intercooled Race Tuner Kit with F-1A-94, F-1C or F-1R	specify	specify	Race	\$10,948
2017-21	1GY300-F1	Competition Race Tuner Kit with F-1D, F-1 or F-1A	specify	specify	1250+ hp AW	\$12,748
2017-21	1GY300-SCI-94	Competition Race Tuner Kit with F-1A-94, F-1C or F-1R	specify	specify	1250+ hp AW	\$12,998

2016-24 CAMARO V6 (3.6) SYSTEM AND KIT

Year	Part Number	Description	Boost Options	HP Gain	Intercooler	Price/MAP
2016-24	1GZ212-SCI	High Output Intercooled System with P-1SC-1	7 psi	45%	750+ hp	\$6,698
2016-24	1GZ202-SCI	High Output Intercooled Tuner Kit with P-1SC-1	specify	specify	750+ hp	\$6,298

Type	Part Number Suffix	Description	Upgrade From	Requirements	Notes	Price/MAP
FINISH OPTIONS	add "B" to part #	Supercharger Finish: Black, max 9.75" housing	satn	max 9.75" housing	-	+\$295
	add "P" to part #	Supercharger Finish: Polished, max 9.75" housing	satn	max 9.75" housing	-	+\$400
	add "BB" to part #	Supercharger Bracket Finish: Black	satn	-	-	+\$225
	add "PB" to part #	Supercharger Bracket Finish: Polished	satn	-	-	+\$325
	add "BIC" to part #	Intake Manifold Finish: Black	raw	-	N/A for V6	+\$225
SUPER-CHARGERS	add "BC" to part #	Intake Manifold Cover Finish: Black	raw	-	N/A for V6	+\$35
	add "P1X" to part #	Supercharger Upgrade: P-1X	P-1SC-1	-	N/A for factory airbox, V6	+\$250
	add "P1R" to part #	Supercharger Upgrade: P-1R	P-1SC-1	Stage II Tuner Kits only	-	+\$600
	add "D1SC" to part #	Supercharger Upgrade: D-1SC	P-1SC-1	Stage II Tuner Kits only	-	+\$300
	add "D1X" to part #	Supercharger Upgrade: D-1X	P-1SC-1	Stage II Tuner Kits only	N/A for factory airbox	+\$500
	add "D" or "1" or "A"	Supercharger Upgrade: F-1D, F-1, F-1A	P-1SC-1	Stage II Tuner Kits only	-	+\$900
	add ".94" to part #	Supercharger Upgrade: F-1A-94	P-1SC-1	Stage II Tuner Kits only	N/A for factory airbox	+\$1,250
	add ".103" to part #	Supercharger Upgrade: F-1R-103	P-1SC-1	Stage II Tuner Kits only	-	+\$2,300
	add "F1X" to part #	Supercharger Upgrade: F-1X	P-1SC-1	Stage II Tuner Kits only	-	+\$2,500
	add "D1X" to part #	Supercharger Upgrade: D-1X	D-1SC	Stage II Tuner Kits only	N/A for SS	+\$200
KIT UPGRADES	add "D" or "1" or "A"	Supercharger Upgrade: F-1D, F-1, F-1A	D-1SC	Stage II Tuner Kits only	N/A for SS	+\$575
	add ".94" to part #	Supercharger Upgrade: F-1A-94	D-1SC	Stage II Tuner Kits only	N/A for SS	+\$925
	add "H" to part #	Gears: Helical gears for noise reduction	straight-cut	P- or D-series only	-	+\$110
	add "RVR" or "RVB"	Race Blow-off Valve Upgrade, open only (specify alum or steel, red or blk)	ProFlow	Stage II only	-	+\$295
	add "RVR" or "RVB"	Race Blow-off Valve Upgrade (specify open or closed, alum or steel, red or blk)	Bullet	-	-	+\$170
	add "INT" to part #	Sheet Metal Aluminum Intake Manifold and Cover	raw	Stage II Tuner Kits only	-	+\$2,498
	add "INT/INJ" to part #	Sheet Metal Aluminum Intake Manifold and Cover w/ injector bungs and fuel rails	raw	Stage II Tuner Kits only	-	+\$2,998
	add "INT/INJ" to part #	Upgrade intake manifold for use with port injection	raw	ZL1 Stage II Tuner Kits only	N/A for SS	+\$500
	add ".10R" to part #	10-rib drive system upgrade	8-rib	Tuner Kits only	N/A for V6	+\$360
	add "ATIPP" to part #	ATI Performance Products Balancer Upgrade	-	P/N 918856	N/A for V6	+\$550
V6 ONLY	add "CP" to part #	8.25" Crank Pulley Upgrade	7.65" standard	-	N/A for V6	+\$120
	add "Race" to part #	Intercooler Upgrade: Air-to-Air Race	Stage II	Stage II Tuner Kits only	N/A for V6	+\$435
	add "AWR" to part #	Intercooler Upgrade: Air-to-Water Race	Stage II	ZL1 Stage II Tuner Kits only	-	+\$2,499
	add "AIR" to part #	Air Inlet Upgrade: Stage II Package	factory airbox	-	-	+\$45

SPECIFICATIONS

2016-24 CAMARO SS (LT1) SPECIFICATIONS

Year	Part Number	OEM hp Rating	HP Gain	Tube Diam	Intercooler Mount	Drive System	Blow-off System	Fuel System Upgrade	Fuel Inj. Supplied	Computer/Ignition Modifications	Supercharger Warranty (in months)	CARB E.O.	Foot Notes
2016-24	1GY211-SCI	455	150+ hp	3"	V	stk 6-rib	Bullet	not required	not required	programmer supplied	12, 36 opt. (\$99)	D-365-40 (16-24)	N: 1, 10
2016-24	"add -SII"	455	Add'l 20+ hp	3"	V	stk 6-rib	Bullet	not supplied	not required	programmer supplied	12, 36 opt. (\$99)	D-365-40 (16-24)	N: 1, 10
2016-24	1GY201-SCI	455	specify	3"	V	stk 6-rib	Bullet	not supplied	no	not supplied	12	-	N: 1, 3, 5, 10
2016-24	1GY212-SCI	455	150+ hp	3"	V	add'l 8-rib	ProFlow	not required	not required	programmer supplied	12, 36 opt. (\$99)	-	N: 1, 2, 4, 5, 9
2016-24	1GY202-SCI	455	specify	3"	V	add'l 8-rib	ProFlow	not supplied	no	not supplied	12	-	N: 1, 3, 4, 5, 9
2016-24	1GY312-SCI	455	170+ hp	3"	V	add'l 8-rib	ProFlow	not required	not required	programmer supplied	12, 36 opt. (\$99)	-	N: 1, 2, 4, 5, 6, 9
2016-24	1GY302-SCI	455	specify	3"	V	add'l 8-rib	ProFlow	not supplied	no	not supplied	12	-	N: 1, 3, 4, 5, 6, 9
2016-24	1GY402-F1	455	specify	3"	V	add'l 8-rib	Race	not supplied	no	not supplied	12	-	N: 1, 3, 4, 5, 6, 9
2016-24	1GY402-SCI-94	455	specify	3"	V	add'l 8-rib	Race	not supplied	no	not supplied	12	-	N: 1, 3, 4, 5, 6, 9

2017-21 CAMARO ZL1 (LT4) SPECIFICATIONS

Year	Part Number	OEM hp Rating	HP Gain	Tube Diam	Intercooler Mount	Drive System	Blow-off System	Fuel System Upgrade	Fuel Inj. Supplied	Computer/Ignition Modifications	Supercharger Warranty (in months)	CARB E.O.	Foot Notes
2017-21	1GY204-SCI	650	specify	3"	V	add'l 8-rib	Bullet	not supplied	no	not supplied	12	-	N: 1, 3, 6, 7, 8, 9
2017-21	1GY204-SCI	650	specify	3"	V	add'l 8-rib	Bullet	not supplied	no	not supplied	12	-	N: 1, 3, 6, 7, 8, 9
2017-21	1GY404-F1	650	specify	3"	V	add'l 8-rib	Race	not required	no	not supplied	12	-	N: 1, 3, 6, 7, 8, 9
2017-21	1GY404-SCI-94	650	specify	3"	V	add'l 8-rib	Race	not supplied	no	not supplied	12	-	N: 1, 3, 6, 7, 8, 9
2017-21	1GY300-F1	650	specify	3"	A/W	add'l 8-rib	Race	not supplied	no	not supplied	12	-	N: 1, 3, 6, 7, 8, 9
2017-21	1GY300-SCI-94	650	specify	3"	A/W	add'l 8-rib	Race	not supplied	no	not supplied	12	-	N: 1, 3, 6, 7, 8, 9

2016-24 CAMARO V6 (3.6) SPECIFICATIONS

Year	Part Number	OEM hp Rating	HP Gain	Tube Diam	Intercooler Mount	Drive System	Blow-off System	Fuel System Upgrade	Fuel Inj. Supplied	Computer/Ignition Modifications	Supercharger Warranty (in months)	CARB E.O.	Foot Notes
2016-24	1GZ212-SCI	335	call	3"	V	stk 6-rib	ProFlow	not required	not required	programmer supplied	12, 36 opt. (\$99)	D-365-27 (16-20)	N: 1, 10
2016-24	1GZ202-SCI	335	specify	3"	V	stk 6-rib	ProFlow	not supplied	no	not supplied	12	-	N: 1, 10

CHEVROLET AUTOMOTIVE FOOTNOTES (specific to above applications):

- N1) Model year must be specified
- N2) Due to variability among OEM computers, the prevalence of custom modifications, and age/miles/condition of vehicles, dyno tuning may be required
- N3) F-1X head unit requires additional modifications
- N4) Race intercooler upgrades requires trimming and removal of driver-side radiator
- N5) Specify stock or aftermarket balancer
- N6) Inner fender modifications required for 9.75+ inch head units
- N7) Inner bumper support modification or removal required for Race and Air-to-Water intercoolers
- N8) Requires ATI PP balancer #918856 (not included - specify hardened hub)
- N9) Works with maximum of 10% overdrive crank pulley
- N10) Factory balancer only



2010-15 CAMARO SS (LS3, L99) SYSTEMS AND KITS

Year	Part Number	Description	Boost Options	HP Gain	Intercooler	Price/MAP
2010-15	1GT214-SCI	High Output Intercooled System with supplied airbox and P-1SC-1	7 psi	50%+	3 core	\$8,948
2010-15	1GT212-SCI	High Output Intercooled System with P-1SC-1	7 psi	50%+	3 core	\$8,598
2010-15	1GT202-SCI	High Output Intercooled Tuner Kit with P-1SC-1	specify	specify	3 core	\$7,698
2010-15	1GT314-SCI	Stage II Intercooled System with supplied airbox and P-1SC-1	7.5 psi	55%+	Stage II	\$9,598
2010-15	1GT312-SCI	Stage II Intercooled System with P-1SC-1	7.5 psi	55%+	Stage II	\$9,248
2010-15	1GT302-SCI	Stage II Intercooled Tuner Kit with P-1SC-1	specify	specify	Stage II	\$8,298

2014-15 CAMARO Z/28 (LS7) SYSTEMS AND KITS

Year	Part Number	Description	Boost Options	HP Gain	Intercooler	Price/MAP
2014-15	1GT414-SCI	Stage II Intercooled System with P-1SC-1	6.5 psi	120+ hp	750+ hp	\$9,148
2014-15	1GT404-SCI	Stage II Intercooled Tuner Kit with P-1SC-1	specify	specify	750+ hp	\$8,248

2010-15 CAMARO SS COG RACE KITS

Year	Part Number	Description	Boost Options	HP Gain	Intercooler	Price/MAP
2010-15	1GT200-F1J	Intercooled Cog Race Kit with F-1D, F-1, or F-1A	specify	specify	Stage II	\$10,298
2010-15	1GT200-F1	Cog Race Kit with F-1D, F-1, or F-1A	specify	specify	-	\$8,798

Type	Part Number Suffix	Description	Upgrade From	Requirements	Notes	Price/MAP
FINISH OPTIONS	add "B" to part #	Supercharger Finish: Black, max 9.75" housing	satin	max 9.75" housing	-	+\$295
	add "P" to part #	Supercharger Finish: Polished, max 9.75" housing	satin	max 9.75" housing	-	+\$400
	add "B" to part #	Supercharger Finish: Black, 10.5" housing	satin	10.5" housing	-	+\$395
	add "P" to part #	Supercharger Finish: Polished, 10.5" housing	satin	10.5" housing	-	+\$500
	add "BB" to part #	Supercharger Bracket Finish: Black	satin	-	-	+\$225
	add "PB" to part #	Supercharger Bracket Finish: Polished	satin	-	-	+\$325
SUPER-CHARGERS	add "-P1X" to part #	Supercharger Upgrade: P-1X	P-1SC-1	excludes Race Kits	add'l 10-15+ hp	+\$250
	add "-P1R" to part #	Supercharger Upgrade: P-1R	P-1SC-1	Tuner Kits only	-	+\$600
	add "-D1SC" to part #	Supercharger Upgrade: D-1SC	P-1SC-1	Tuner Kits only	-	+\$300
	add "-D1X" to part #	Supercharger Upgrade: D-1X	P-1SC-1	Tuner Kits only	-	+\$500
	add "-D" or "-1" or "-A"	Supercharger Upgrade: F-1D, F-1, F-1A	P-1SC-1	Tuner Kits only	-	+\$900
	add "-94" or "-C" or "-R"	Supercharger Upgrade: F-1A-94, F-1C or F-1R	P-1SC-1	Tuner Kits only	-	+\$1,250
	add "-103" to part #	Supercharger Upgrade: F-1R-103	P-1SC-1	Tuner Kits only	-	+\$2,300
	add "-F1X" to part #	Supercharger Upgrade: F-1X	P-1SC-1	SS Tuner Kits only	-	+\$2,500
	add "-94" or "-C" or "-R"	Supercharger Upgrade: F-1A-94, F-1C or F-1R	F-1A	Cog Race Kits only	-	+\$350
	add "-F1X" to part #	Supercharger Upgrade: F-1X	F-1D, F-1, F-1A	Cog Race Kits only	-	+\$1,600
KIT UPGRADES	add "H" to part #	Gears: Helical gearset for noise reduction	straight-cut	P- or D-series only	-	+\$110
	add "-RVR" or "RVB"	Race Blow-off Valve Upgrade (specify open or closed, alum or steel, red or blk)	ProFlow	excludes Race Kits	-	+\$295
	add "-AIR" to part #	Air Inlet Upgrade: Stage II Package	HO std inlet	SS only	-	+\$45
	add "-10R" to part #	10-rib drive system upgrade	8-rib	SS Stage II Tuner Kits only	-	+\$360
	add "-Race" to part #	Intercooler Upgrade: Race air-to-air, 1300 HP max	Stage II	SS Stage II Tuner Kits only	-	+\$435
	add "-ATIPP" to part #	ATI Performance Products Balancer Upgrade	-	SS only	-	+\$550
	add "-Race" to part #	Intercooler Upgrade: Race air-to-air, 1200+ HP	750+ HP	Z/28 Tuner Kits only	-	+\$435
	add "-Race" to part #	Intercooler Upgrade: Race air-to-air, 1300 HP max	Stage II	Cog Race Kits only	3.5" in/outlet	+\$435
	W11005A-001	Intercooler Upgrade: Air-to-Water Race, 1800 HP max	non-IC kit	Cog Race Kits only	-	+\$2,498
	W11005A-002	Intercooler Upgrade: Air-to-Water Race, 2,500 HP max	non-IC kit	Cog Race Kits only	-	+\$2,998
i-1 ONLY	SEE PAGE 88 FOR i-1 OPTIONS					

2010-15 CAMARO SS (LS3, L99) i-1 PROGRAMMABLE RATIO SYSTEMS

Year	Part Number	Description	Boost Options	HP Gain	Intercooler	Price/MAP
2010-15	1GT313-SCI	Stage II Intercooled System with i-1	7.5 psi	55%+	Race	\$13,498

SPECIFICATIONS

2010-15 CAMARO SS (LS3, L99) SPECIFICATIONS

Year	Part Number	OEM hp Rating	HP Gain	Tube Diam	Intercooler Mount	Drive System	Blow-off System	Fuel System Upgrade	Fuel Inj. Supplied	Computer/Ignition Modifications	Supercharger Warranty (in months)	CARB E.O.	Foot Notes
2010-15	1GT214-SCI	426/400	50%+	3"	V	add'l 8-rib	ProFlow	not required	50 lb/hr	programmer supplied	12, 36 opt. (\$99)	D-365-13	O: 1, 4, 6
2010-15	1GT212-SCI	426/400	50%+	3"	V	add'l 8-rib	ProFlow	not required	50 lb/hr	programmer supplied	12, 36 opt. (\$99)	-	O: 1, 2, 4, 6
2010-15	1GT202-SCI	426/400	specify	3"	V	add'l 8-rib	ProFlow	not supplied	no	not supplied	12	-	O: 1, 4, 6, 10
2010-15	1GT314-SCI	426/400	55%+	3"	V	add'l 8-rib	ProFlow	pump voltage booster	50 lb/hr	programmer supplied	12, 36 opt. (\$99)	D-365-13	O: 1, 4, 6
2010-15	1GT312-SCI	426/400	55%+	3"	V	add'l 8-rib	ProFlow	pump voltage booster	50 lb/hr	programmer supplied	12, 36 opt. (\$99)	-	O: 1, 2, 4, 6
2010-15	1GT302-SCI	426/400	specify	3"	V	add'l 8-rib	ProFlow	not supplied	no	not supplied	12	-	O: 1, 4, 5, 6, 10

2014-15 CAMARO Z/28 (LS7) SPECIFICATIONS

Year	Part Number	OEM hp Rating	HP Gain	Tube Diam	Intercooler Mount	Drive System	Blow-off System	Fuel System Upgrade	Fuel Inj. Supplied	Computer/Ignition Modifications	Supercharger Warranty (in months)	CARB E.O.	Foot Notes
2014-15	1GT414-SCI	505	120+ hp	3"	V	add'l 8-rib	ProFlow	pump voltage booster	65 lb/hr	programmer supplied	12, 36 opt. (\$99)	-	O: 1, 2, 4, 5, 6
2014-15	1GT404-SCI	505	specify	3"	V	add'l 8-rib	ProFlow	not supplied	no	not supplied	12	-	O: 1, 4, 5, 6, 10

2010-15 CAMARO SS COG RACE KIT SPECIFICATIONS

Year	Part Number	OEM hp Rating	HP Gain	Tube Diam	Intercooler Mount	Drive System	Blow-off System	Fuel System Upgrade	Fuel Inj. Supplied	Computer/Ignition Modifications	Supercharger Warranty (in months)	CARB E.O.	Foot Notes
2010-15	1GT200-F1J	-	specify	3"/3.5"	V	Cog	Race	not supplied	no	not supplied	Limited	-	O: 1, 4, 5, 8, 9, 10
2010-15	1GT200-F1	-	specify	-	-	Cog	Race	not supplied	no	not supplied	Limited	-	O: 1, 4, 5, 8, 9, 10

2010-15 CAMARO SS (LS3, L99) i-1 SPECIFICATIONS

Year	Part Number	OEM hp Rating	HP Gain	Tube Diam	Intercooler Mount	Drive System	Blow-off System	Fuel System Upgrade	Fuel Inj. Supplied	Computer/Ignition Modifications	Supercharger Warranty (in months)	CARB E.O.	Foot Notes
2010-15	1GT313-SCI	426/400	55%+	3"	V	add'l 8-rib	ProFlow	pump voltage booster	50 lb/hr	programmer supplied	12, 36 opt. (\$599)	-	O: 1, 2, 6, 7, 11

CHEVROLET AUTOMOTIVE FOOTNOTES (specific to above applications):

- O1) Model year must be specified
- O2) Due to variability among OEM computers, the prevalence of custom modifications, and age/miles/condition of vehicles, dyno tuning may be required
- O4) Race intercooler upgrades may require modifications
- O5) 2010-15 Cog and 10-rib requires ATI Balancer ATI PP #918635 (not included - specify hardened hub)
- O6) Stage II air inlet and air inlet upgrade package require auxiliary battery bracket relocation (supplied)
- O7) Two-part shipment, additional shipping charges may apply
- O8) Requires coolant hose modifications
- O9) Bracket brace and Kevlar COG belt recommended
- O10) 9.75" and larger head unit requires modification of strut tower and power steering reservoir (10-11) and inner fender
- O11) Special order kit: order form and non-refundable deposit required at time of order—may require additional lead time for processing



1998-02 CAMARO/FIREBIRD (LS1) SYSTEMS AND KITS

Year	Part Number	Description	Boost Options	HP Gain	Intercooler	Price/MAP
1999-02	1GJ214-SCI	High Output Intercooled System with P-1SC-1	5, 7 psi	40-55%	3.5" twin highflow	\$8,698
1998-02	1GJ213-SCI	High Output Intercooled Tuner Kit with P-1SC-1	specify	specify	3.5" twin highflow	\$7,848
1998-02	1GJ204-SCI	Intercooled Serpentine Race Kit with D-1SC (8-rib with spring tensioner)	specify	specify	4.5" twin highflow	\$8,648

1993-97 CAMARO/FIREBIRD (LT1) SYSTEMS AND KITS

Year	Part Number	Description	Boost Options	HP Gain	Intercooler	Price/MAP
1993-97	1GA211-071 / 091	High Output Intercooled System with P-1SC	7, 9 psi	55-60%	2 core	\$6,998
1993-97	1GA201-SCI	High Output Intercooled Tuner Kit with P-1SC	specify	specify	2 core	\$6,698
1993-97	1GA212-D1SC	Intercooled Serpentine Race Kit with D-1SC (12-rib)	specify	specify	twin highflow	\$7,648

1987-92 CAMARO/FIREBIRD TPI (L98) SYSTEMS AND KITS

Year	Part Number	Description	Boost Options	HP Gain	Intercooler	Price/MAP
1987*-92	1GC211-091	High Output Intercooled System with P-1SC	9 psi	65%	2 core	\$6,248
1987*-92	1GC201-SCI	High Output Intercooled Tuner Kit with P-1SC	specify	specify	2 core	\$5,998
1987*-92	1GC201-D1SC	Stage II Intercooled Tuner Kit with D-1SC	specify	specify	3 core	\$6,798

Applications	Part Number Suffix	Description	Upgrade From	Requirements	Notes	Price/MAP
LS1 ONLY	add "B" to part #	Supercharger Finish: Black, max 9.75" housing	satin	max 9.75" housing	-	+\$295
	add "P" to part #	Supercharger Finish: Polished, max 9.75" housing	satin	max 9.75" housing	-	+\$400
	add "PP" to part #	Intake Plenum Finish: Polished	blk rotomold std	-	-	+\$325
	add "H" to part #	Gears: Helical gearset for noise reduction	straight-cut	P- or D-series only	-	+\$110
	add "D1SC" to part #	Supercharger Upgrade: D-1SC	P-1SC-1	Tuner Kits only	-	+\$300
	add "D" or "1" or "A"	Supercharger Upgrade: F-1D, F-1, F-1A	D-1SC	Stage II Tuner Kits only	-	+\$575
	add "8R" to part #	8-rib drive system upgrade	6-rib	-	-	+\$275
	add "10R" to part #	10-rib drive system upgrade	8-rib	Race Kit only	-	+\$360
	add "4.5" to part #	Intercooler Upgrade: 4.5" Twin Highflow, 850 HP max	3.5" Twin	-	850 hp max	+\$345
	add "3C" to part #	Intercooler Upgrade: Race 3-core air-to-air	4.5" Twin HF	Race Kit only	race valve req'd	+\$275
	add "BI" to part #	Intercooler Finish: Black	raw	Race Intercooler only	-	+\$195
	add "RVR" or "RVB"	Race Blow-off Valve Upgrade (specify open or closed, alum or steel, red or blk)	ProFlow	Race Kit only	-	+\$295
LT1 ONLY	add "ATIPP" to part #	ATI Performance Products Balancer Upgrade	-	8- or 10-rib	P/N 918853	+\$550
	3GKMM-004	Crank Pin Kit	-	-	-	+\$109
	add "B" to part #	Supercharger Finish: Black, max 9.75" housing	satin	max 9.75" housing	-	+\$295
	add "P" to part #	Supercharger Finish: Polished, max 9.75" housing	satin	max 9.75" housing	-	+\$400
	add "I" to part #	Intake Tract Finish: Polished	raw	-	-	+\$200
	add "H" to part #	Gears: Helical gearset for noise reduction	straight-cut	same	-	+\$110
	add "D1SC" to part #	Supercharger Upgrade: D-1SC	P-1SC	HO only	-	+\$525
	add "D" or "1" or "A"	Supercharger Upgrade: F-1D, F-1, F-1A	D-1SC	Race Kit only	-	+\$575
	add "RVR" or "RVB"	Race Blow-off Valve Upgrade (specify open or closed, alum or steel, red or blk)	ProFlow	-	-	+\$295
	add "THF" to part #	Intercooler Upgrade: Twin Highflow, 750 HP max	ProFlow	-	-	+\$295
	MA0011-001	Mass Airflow Massager	-	96-97 only	-	+\$249
	L98 ONLY	add "B" to part #	Supercharger Finish: Black, max 9.75" housing	satin	max 9.75" housing	-
add "P" to part #		Supercharger Finish: Polished, max 9.75" housing	satin	max 9.75" housing	-	+\$400
add "BB" to part #		Supercharger Bracket Finish: Black	satin	-	-	+\$225
add "PB" to part #		Supercharger Bracket Finish: Polished	satin	-	-	+\$325
add "H" to part #		Gears: Helical gearset for noise reduction	straight-cut	P- or D-series only	-	+\$110
add "D1SC" to part #		Supercharger Upgrade: D-1SC	P-1SC	-	-	+\$525
add "3C" to part #		Intercooler Upgrade: 3-core air-to-air, 825 HP max	2-core	-	-	+\$435
add "OF" to part #		Omit FMU	-	Stage II only	-	-\$88
add "OP" to part #		Omit in-line fuel pump	-	Stage II only	-	-\$98

OPTIONS FOR THIS PAGE

SPECIFICATIONS

1998-02 CAMARO/FIREBIRD (LS1) SPECIFICATIONS

Year	Part Number	OEM hp Rating	HP Gain	Tube Diam	IC Mount	Drive System	Blow-off System	Fuel System Upgrade	Fuel Inj. Supplied	Computer/Ignition Modifications	Supercharger Warranty (in months)	CARB E.O.	Foot Notes
1999-02	1GJ214-SCI	310-325	40-55%	2.5" ea	H	add'l 6-rib	ProFlow	ProPump	38 lb/hr	programmer sup.	12, 36 opt. (\$99)	D-365-6	P: 1, 9, 10
1998-02	1GJ213-SCI	310-325	specify	2.5" ea	H	add'l 6-rib	ProFlow	not supplied	No	not supplied	12	-	P: 1, 9, 10, 14
1998-02	1GJ204-SCI	310-325	specify	2.5" ea	H	add'l 8-rib	ProFlow	not supplied	No	not supplied	12	-	P: 1, 9, 10, 13, 14, 17

1993-97 CAMARO/FIREBIRD (LT1) SPECIFICATIONS

Year	Part Number	OEM hp Rating	HP Gain	Tube Diam	IC Mount	Drive System	Blow-off System	Fuel System Upgrade	Fuel Inj. Supplied	Computer/Ignition Modifications	Supercharger Warranty (in months)	CARB E.O.	Foot Notes
1993-97	1GA211-071/091	275-305	55-60%	3"	H	add'l 8-rib	ProFlow	ProPump	not required	not required	12, 36 opt. (\$99)	D-365-3 (93-95)	P: 1, 2, 3, 4, 16
1993-97	1GA201-SCI	275-305	specify	3"	H	add'l 8-rib	ProFlow	not supplied	not required	not required	12	-	P: 1, 2, 3, 4, 16
1993-97	1GA212-D1SC	275-305	specify	3.5" ea	H	add'l 12-rib	ProFlow	not supplied	No	not supplied	12	-	P: 1, 2, 3, 6, 8, 14, 16

1987-92 CAMARO/FIREBIRD TPI (L98) SPECIFICATIONS

Year	Part Number	OEM hp Rating	HP Gain	Tube Diam	IC Mount	Drive System	Blow-off System	Fuel System Upgrade	Fuel Inj. Supplied	Computer/Ignition Modifications	Supercharger Warranty (in months)	CARB E.O.	Foot Notes
1987-92	1GC211-091	230-245	65%	3"	H	add'l 8-rib	ProFlow	ProPump	No	not required	12, 36 opt. (\$99) for 9 psi	D-365-3 (88-92)	P: 1, 12, 16
1987-92	1GC201-SCI	230-245	specify	3"	H	add'l 8-rib	ProFlow	not supplied	No	not required	12	-	P: 1, 12, 16
1987-92	1GC201-D1SC	230-245	specify	3"	H	add'l 8-rib	ProFlow	not supplied	No	not required	12	-	P: 1, 12, 16

CHEVROLET/PONTIAC AUTOMOTIVE FOOTNOTES (specific to above applications):

- P1) Model year must be specified
- P2) Mass airflow massager required for '96-97 LT1's (sold separately by ProCharger)
- P3) LT1 F-bodies with traction control will require custom relocation of that module
- P4) 1993 LT1 F-bodies require the purchase of larger fuel injectors or an ignition retard system (sold separately by others)
- P5) May not accommodate all aftermarket balancers
- P6) Modified engines only
- P8) D-1SC, F-1, F-1A modified engines only (air inlet may require modification)
- P9) Pinning the balancer to the crank is recommended; Pin kit for stock balancer not supplied
- P10) Purchase of specific aftermarket harmonic balancer required for 8 rib and 10 rib upgrade, modifications required (ATI PP part #918853) (not included - specify hardened hub)
- P12) 1987 model years require Serpentine Accessory Belt Drive System, GM Part # 12497698
- P13) Race intercooler upgrade requires race valve and front bumper modification
- P14) F-series head unit upgrades may require minor modifications
- P16) Special order kit: order form and non-refundable deposit required at time of order—may require additional lead time for processing
- P17) Sway bar spacing may be required



2016-19 CADILLAC CTS-V (LT4)

Year	Part Number	Description	Boost Options	HP Gain	Intercooler	Price/MAP
2016-19	1GY704-SCI	Stage II Intercooled Tuner Kit with D-1SC	specify	specify	Stage II	\$9,998

2014-17 CHEVROLET SS SYSTEMS AND KITS

Year	Part Number	Description	Boost Options	HP Gain	Intercooler	Price/MAP
2014-17	1GW212-SCI	High Output Intercooled System with P-1SC-1	8 psi	50%	2 Core	\$8,598
2014-17	1GW202-SCI	High Output Intercooled Tuner Kit with P-1SC-1	specify	specify	2 Core	\$7,948

2008-09 PONTIAC G8 GT SYSTEMS AND KITS

Year	Part Number	Description	Boost Options	HP Gain	Intercooler	Price/MAP
2008-09	1GS212-SCI	High Output Intercooled System with P-1SC-1	8 psi	50-55%	2 Core	\$8,698
2008-09	1GS202-SCI	High Output Intercooled Tuner Kit with P-1SC-1	specify	specify	2 Core	\$7,998

2004-06 PONTIAC GTO (LS1, LS2) SYSTEMS AND KITS

Year	Part Number	Description	Boost Options	HP Gain	Intercooler	Price/MAP
2005-06 (LS2)	1GN312-SCI	High Output Intercooled System with P-1SC-1	7 psi	50%	GTO	\$8,698
2005-06 (LS2)	1GN302-SCI	High Output Intercooled Tuner Kit with P-1SC-1	specify	specify	GTO	\$7,798
2005-06 (LS2)	1GN313-F1A	Intercooled Serpentine Race Kit with F-1D, F-1, or F-1A	specify	specify	GTO	\$8,848
2004 (LS1)	1GN212-SCI	High Output Intercooled System with P-1SC-1	7 psi	50%	GTO	\$8,748
2004 (LS1)	1GN202-SCI	High Output Intercooled Tuner Kit with P-1SC-1	specify	specify	GTO	\$7,848
2004 (LS1)	1GN213-F1A	Intercooled Serpentine Race Kit with F-1D, F-1, or F-1A	specify	specify	GTO	\$8,848

Applications	Part Number Suffix	Description	Upgrade From	Requirements	Notes	Price/MAP
ALL	add "B" to part #	Supercharger Finish: Black, max 9.75" housing	satn	max 9.75" housing	-	+\$295
	add "P" to part #	Supercharger Finish: Polished, max 9.75" housing	satn	max 9.75" housing	-	+\$400
	add "BB" to part #	Supercharger Bracket Finish: Black	satn	-	-	+\$225
	add "PB" to part #	Supercharger Bracket Finish: Polished	satn	-	-	+\$325
	add "H" to part #	Gears: Helical gearset for noise reduction	straight-cut	P- or D-series only	-	+\$110
	add "D1SC" to part #	Supercharger Upgrade: D-1SC	P-1SC-1	Tuner Kits only	-	+\$300
CTS-V ONLY	add "D1X" to part #	Supercharger Upgrade: D-1X	D-1SC	-	-	+\$200
	add "D" or "-1" or "-A"	Supercharger Upgrade: F-1D, F-1, F-1A	D-1SC	-	-	+\$575
	add "94" to part #	Supercharger Upgrade: F-1A-94	D-1SC	-	-	+\$925
	add "RVR" or "RVB"	Race Blow-off Valve Upgrade (specify open or closed, alum or steel, red or blk)	Bullet	-	-	+\$170
	add "Race" to part #	Intercooler Upgrade: Air-to-Air Race	Stage II	-	-	+\$435
	add "INT/INJ" to part #	Upgrade intake manifold for use with port injection	raw	Tuner Kits only	-	+\$500
	add "10R" to part #	10-rib drive system upgrade	8-rib	-	-	+\$360
	add "ATIPP" to part #	ATI Performance Products Balancer Upgrade	-	P/N 918856	-	+\$550
	add "CP" to part #	8.25" Crank Pulley Upgrade	7.65" std	-	-	+\$120
	add "BIC" to part #	Intake Manifold Finish: Black	raw	-	-	+\$225
SS ONLY	add "BC" to part #	Intake Manifold Cover Finish: Black	raw	-	-	+\$35
	add "P1X" to part #	Supercharger Upgrade: P-1X	P-1SC-1	-	add'l 10-15+ hp	+\$250
	add "P1R" to part #	Supercharger Upgrade: P-1R	P-1SC-1	Tuner Kits only	-	+\$600
	add "D1X" to part #	Supercharger Upgrade: D-1X	P-1SC-1	Tuner Kits only	-	+\$500
	add "D" or "-1" or "-A"	Supercharger Upgrade: F-1D, F-1, F-1A	P-1SC-1	Tuner Kits only	-	+\$900
	add "94" to part #	Supercharger Upgrade: F-1A-94	P-1SC-1	Tuner Kits only	-	+\$1,250
G8 ONLY	add "RVR" or "RVB"	Race Blow-off Valve Upgrade, open only (specify alum or steel, red or blk)	ProFlow	-	-	+\$295
	add "3C" to part #	Intercooler Upgrade: 3-core air-to-air, 825 HP max	2-core	-	3" tubing	+\$435
	add "D" or "-1" or "-A"	Supercharger Upgrade: F-1D, F-1, F-1A	P-1SC-1	Tuner Kits only	-	+\$900
	add "RVR" or "RVB"	Race Blow-off Valve Upgrade, open only (specify alum or steel, red or blk)	ProFlow	-	-	+\$295
GTO ONLY	add "RVR" or "RVB"	Race Blow-off Valve Upgrade (specify open or closed, alum or steel, red or blk)	ProFlow	-	-	+\$295
	add "Race" to part #	Intercooler Upgrade: Race air-to-air, 1000 HP max	GTO	-	see footnote Q8	+\$750
	add "ATIPP" to part #	ATI Performance Products Balancer Upgrade	-	8-rib only	P/N 918853	+\$550

CALL FOR CAPRICE PPV INFORMATION

SPECIFICATIONS

2016-19 CADILLAC CTS-V (LT4) SPECIFICATIONS

Year	Part Number	OEM hp Rating	HP Gain	Tube Diam	Intercooler Mount	Drive System	Blow-off System	Fuel System Upgrade	Fuel Inj. Supplied	Computer/Ignition Modifications	Supercharger Warranty (in months)	CARB E.O.	Foot Notes
2016-19	1GY704-SCI	650	specify	3"	V	add'l 8-rib	Bullet	not supplied	no	not supplied	12	-	Q: 1, 6, 13

2014-17 CHEVROLET SS SPECIFICATIONS

Year	Part Number	OEM hp Rating	HP Gain	Tube Diam	Intercooler Mount	Drive System	Blow-off System	Fuel System Upgrade	Fuel Inj. Supplied	Computer/Ignition Modifications	Supercharger Warranty (in months)	CARB E.O.	Foot Notes
2014-17	1GW212-SCI	415	50%	3"	V	add'l 8-rib	ProFlow	not required	50 lb/hr	programmer sup.	12, 36 opt. (\$99)	-	Q: 1, 2, 3
2014-17	1GW202-SCI	415	specify	3"	V	add'l 8-rib	ProFlow	not supplied	no	not supplied	12	-	Q: 1, 2

2008-09 PONTIAC G8 GT SPECIFICATIONS

Year	Part Number	OEM hp Rating	HP Gain	Tube Diam	Intercooler Mount	Drive System	Blow-off System	Fuel System Upgrade	Fuel Inj. Supplied	Computer/Ignition Modifications	Supercharger Warranty (in months)	CARB E.O.	Foot Notes
2008-09	1GS212-SCI	361	50-55%	3"	V	add'l 8-rib	ProFlow	not required	50 lb/hr	programmer sup.	12, 36 opt. (\$99)	-	Q: 1, 2, 3, 7, 9, 11
2008-09	1GS202-SCI	361	specify	3"	V	add'l 8-rib	ProFlow	not supplied	no	not supplied	12	-	Q: 1, 2, 7, 9, 12

2004-2006 PONTIAC GTO (LS1, LS2) SPECIFICATIONS

Year	Part Number	OEM hp Rating	HP Gain	Tube Diam	Intercooler Mount	Drive System	Blow-off System	Fuel System Upgrade	Fuel Inj. Supplied	Computer/Ignition Modifications	Supercharger Warranty (in months)	CARB E.O.	Foot Notes
2005-06	1GN312-SCI	400	50%	3"	V	add'l 8-rib	ProFlow	not required	57 lb/hr	programmer sup.	12, 36 opt. (\$99)	-	Q: 1, 2, 3, 4, 5, 8
2005-06	1GN302-SCI	400	specify	3"	V	add'l 8-rib	ProFlow	not supplied	No	not supplied	12	-	Q: 1, 2, 4, 5, 8
2005-06	1GN313-F1A	-	specify	3"	V	add'l 8-rib	Race	not supplied	No	not supplied	12	-	Q: 1, 2, 4, 5, 8, 10
2004	1GN212-SCI	350	50%	3"	V	add'l 8-rib	ProFlow	not required	38 lb/hr	programmer sup.	12, 36 opt. (\$99)	D-365-6	Q: 1, 2, 4, 5, 8
2004	1GN202-SCI	350	specify	3"	V	add'l 8-rib	ProFlow	not supplied	No	not supplied	12	-	Q: 1, 2, 4, 5, 8
2004	1GN213-F1A	-	specify	3"	V	add'l 8-rib	Race	not supplied	No	not supplied	12	-	Q: 1, 2, 4, 5, 8, 10

CHEVROLET/PONTIAC AUTOMOTIVE FOOTNOTES (specific to above applications):

- Q1) Model year must be specified
- Q2) Pinning the balancer to the crank is recommended; Pin kit for stock balancer is supplied
- Q3) Due to variability among OEM computers, the prevalence of custom modifications, and age/miles/condition of vehicles, dyno tuning may be required
- Q4) Specify stock or aftermarket balancer, and stock or overdrive diameter crank pulley (if aftermarket balancer, requires ATI PP part #918853, not included - specify hardened hub)
- Q5) May require transmission cooling line modification
- Q6) Requires ATI PP balancer #918856 (not included - specify hardened hub)
- Q7) 2009 G8 requires GM balancer part # 12674582
- Q8) Requires modification of front bumper (GTO race intercooler only)
- Q9) Requires modifications for 3 core upgrade
- Q10) Race intercooler recommended above 600 HP
- Q11) Complete systems are compatible with G8 GT models only
- Q12) Tuner Kits are compatible with G8 GT models, and GXP models with modifications
- Q13) Works with maximum of 10% overdrive crank pulley



LS, LT SERPENTINE ACCESSORY DRIVE KIT (PROCHARGER OPTIONAL)

Part Number LS	Part Number LT	Description	Boost Options	HP Gain	Intercooler	Price/MAP
1LS300	1LT300	Serpentine Accessory Drive (with crank pulley + water pump + alternator bracket)	-	-	-	\$2,348
1LS300-PS	1LT300-PS	Serpentine Accessory Drive (with crank pulley + water pump + alternator bracket & p/s bracket)	-	-	-	\$2,698
1LS300-AC	1LT300-AC	Serpentine Accessory Drive (with crank pulley + water pump + alternator bracket & a/c bracket)	-	-	-	\$2,598
1LS300-PS-AC	1LT300-PS-AC	Serpentine Accessory Drive (with crank pulley + water pump + alt bracket, p/s bracket & a/c bracket)	-	-	-	\$2,898
SUPERCHARGER INCLUDED						
1LS400-P1SC1	1LT400-P1SC1	Serpentine Accessory Drive Kit with P-1SC-1 (with water pump and all accessory brackets)	specify	specify	-	\$6,098
1LS400-P1SC1-I	1LT400-P1SC1-I	Serpentine Accessory Drive Kit with Intercooled P-1SC-1 (with water pump and all acc brackets)	specify	specify	2 core 550 hp	\$6,998
1LS400-P1X	1LT400-P1X	Serpentine Accessory Drive Kit with P-1X (with water pump and all accessory brackets)	specify	specify	-	\$6,348
1LS400-P1X-I	1LT400-P1X-I	Serpentine Accessory Drive Kit with Intercooled P-1X (with water pump and all accessory brackets)	specify	specify	2 core 550 hp	\$7,248
1LS400-D1SC	1LT400-D1SC	Serpentine Accessory Drive Kit with D-1SC (with water pump and all accessory brackets)	specify	specify	-	\$6,398
1LS400-D1SC-I	1LT400-D1SC-I	Serpentine Accessory Drive Kit with Intercooled D-1SC (with water pump and all accessory brackets)	specify	specify	3 core 825 hp	\$7,698
1LS400-D1X	1LT400-D1X	Serpentine Accessory Drive Kit with D-1X (with water pump and all accessory brackets)	specify	specify	-	\$6,598
1LS400-D1X-I	1LT400-D1X-I	Serpentine Accessory Drive Kit with Intercooled D-1X (with water pump and all acc brackets)	specify	specify	3 core 825 hp	\$7,798
1LS400-P1R	1LT400-P1R	Serpentine Accessory Drive Kit with P-1R (with water pump and all accessory brackets)	specify	specify	-	\$6,698
1LS400-P1R-I	1LT400-P1R-I	Serpentine Accessory Drive Kit with Intercooled P-1R (with water pump and all accessory brackets)	specify	specify	3 core 825 hp	\$7,898
1LS400-F1D/F1A	1LT400-F1D/F1A	Serpentine Accessory Drive Kit with F-1D, F-1, or F-1A (with water pump and all accessory brackets)	specify	specify	-	\$7,548
1LS400-F1D-I/F1-I/F1A-I	1LT400-F1D-I/F1-I/F1A-I	Serpentine Accessory Drive Kit with Intercooled F-1D, F-1, or F-1A (with w/p and all acc brackets)	specify	specify	3 core 950 hp	\$8,998
1LS400-F1A94/F1C/F1R	1LT400-F1A94/F1C/F1R	Serpentine Accessory Drive Kit with F-1A-94, F-1C or F-1R (with water pump and all accessory brackets)	specify	specify	-	\$7,998
1LS400-F1A94-I/F1C-I/F1R-I	1LT400-F1A94-I/F1C-I/F1R-I	Serpentine Accessory Drive Kit with Intercooled F-1A-94, F-1C or F-1R (w/p and all acc brackets)	specify	specify	3 core 1050 hp	\$9,598
1LS400-103	1LT400-103	Serpentine Accessory Drive Kit with F-1R-103 (with water pump and all accessory brackets)	specify	specify	-	\$9,198
1LS400-103-I	1LT400-103-I	Serpentine Accessory Drive Kit with Intercooled F-1R-103 (with water pump and all accessory brackets)	specify	specify	3 core 1300 hp	\$10,698
1LS400-F1X	1LT400-F1X	Serpentine Accessory Drive Kit with F-1X (10-rib) (with water pump and all accessory brackets)	specify	specify	-	\$9,698
1LS400-F1X-I	1LT400-F1X-I	Serpentine Accessory Drive Kit with Intercooled F-1X (10-rib) with w/p and all acc brackets)	specify	specify	3 core 1300 hp	\$11,198
1LS400-F2	1LT400-F2	Serpentine Accessory Drive Kit with F-2 (10-rib) (with water pump and all accessory brackets)	specify	specify	-	\$9,898
1LS400-F2-I	1LT400-F2-I	Serpentine Accessory Drive Kit with Intercooled F-2 (10-rib) (with w/p and all acc brackets)	specify	specify	3 core 1300 hp	\$11,398

Type	Part Number Suffix	Description	Upgrade From	Requirements	Notes	Price/MAP
ACCESSORIES	omit "-OPB"	Omit power steering belt, bracket & pulley, satin finish	1LX400-PS	-	-	-\$300
	omit "-OAB"	Omit air conditioning bracket & pulley, satin finish	1LX400-AC	-	-	-\$200
	3LSBB-006	Add ProCharger supercharger bracket 8-rib, tensioner & belt, satin finish	1LX300	-	-	+\$650
	add "BWP" to part #	Water Pump Finish: Black	satin	-	-	+\$75
	add "PWP" to part #	Water Pump Finish: Polished	satin	LS only	-	+\$75
	3LSAL-001(B)	Add LS/LT Alternator (w/ wire) 225 AMP, satin or black finish	no Alternator	-	-	+\$499
	3LSAL-001P	Add LS/LT Alternator (w/ wire) 225 AMP, polished finish	no Alternator	-	-	+\$509
	GA100I-002	Add Power Steering Pump GM Type 2, satin finish	no P/S	-	-	+\$160
	GA100I-002B/P	Add Power Steering Pump GM Type 2, black or polished finish	no P/S	-	-	+\$242
	GA100I-001(B)	Add A/C Compressor Sanden SD-7B10, satin or black finish	no A/C	-	-	+\$260
	GA100I-001P	Add A/C Compressor Sanden SD-7B10, polished finish	no A/C	-	-	+\$502
	DC040A-005	Add ATI 8-rib Balancer #917345	-	LS only	-	+\$550
	DC040A-006	Add ATI 10-rib Balancer #917347X	-	LS only	-	+\$550
FINISH OPTIONS	add "-B" to part #	Supercharger Finish: Black, max 9.75" housing	satin	max 9.75" housing	-	+\$295
	add "-P" to part #	Supercharger Finish: Polished, max 9.75" housing	satin	max 9.75" housing	-	+\$400
	add "-B" to part #	Supercharger Finish: Black, 10.5" housing	satin	10.5" housing	-	+\$395
	add "-P" to part #	Supercharger Finish: Polished, 10.5" housing	satin	10.5" housing	-	+\$500
	add "-BB" to part #	Supercharger Bracket Finish: Black	satin	-	-	+\$225
	add "-PB" to part #	Supercharger Bracket Finish: Polished	satin	-	-	+\$325
	add "-BA" to part #	Accessory Bracket Finish: Black	satin	-	-	+\$250
add "-PA" to part #	Accessory Bracket Finish: Polished	satin	-	-	+\$350	
KIT UPGRADES	add "-H" to part #	Gears: Helical gearset for noise reduction	straight-cut	P- or D-series only	-	+\$110
	3GKMM-004	Crank Pin Kit	-	-	-	+\$109
	add "-BV" to part #	Bullet Blow-off Valve Upgrade (black only)	ProFlow	-	-	+\$125
	add "-RVR" or "RVB"	Race Blow-off Valve Upgrade (specify open or closed, alum or steel, red or blk)	ProFlow	-	-	+\$295
INTERCOOLERS	add "-10R" to part #	10-rib drive system upgrade	8-rib	-	-	+\$360

SPECIFICATIONS

LS, LT SERPENTINE ACCESSORY DRIVE KIT SPECIFICATIONS

Part Number LS	Part Number LT	Stock HP	HP Gain	Tube Diam	Accessory Drive	Supercharger Drive	Blow-off Valve	Water Pump	Alternator Bracket	Power Steering Bracket	Air Cond. Bracket	Supercharger Warranty (in months)	Tubing Supplied	Foot Notes
1LS300	1LT300	N/A	specify	-	6-rib	-	-	included	included	-	-	-	-	all
1LS300-PS	1LT300-PS	N/A	specify	-	6-rib	-	-	included	included	included + 4-rib	-	-	-	all
1LS300-AC	1LT300-AC	N/A	specify	-	6-rib	-	-	included	included	-	included	-	-	all
1LS300-PS-AC	1LT300-PS-AC	N/A	specify	-	6-rib	-	-	included	included	included + 4-rib	included	-	-	all
1LS400-P1SC1	1LT400-P1SC1	N/A	specify	-	6-rib	8-rib	ProFlow	included	included	included + 4-rib	included	12	-	all
1LS400-P1SC1-I	1LT400-P1SC1-I	N/A	specify	3"	6-rib	8-rib	ProFlow	included	included	included + 4-rib	included	12	yes	all
1LS400-P1X	1LT400-P1X	N/A	specify	-	6-rib	8-rib	ProFlow	included	included	included + 4-rib	included	12	-	all
1LS400-P1X-I	1LT400-P1X-I	N/A	specify	3"	6-rib	8-rib	ProFlow	included	included	included + 4-rib	included	12	yes	all
1LS400-D1SC	1LT400-D1SC	N/A	specify	-	6-rib	8-rib	ProFlow	included	included	included + 4-rib	included	12	-	all
1LS400-D1SC-I	1LT400-D1SC-I	N/A	specify	3"	6-rib	8-rib	ProFlow	included	included	included + 4-rib	included	12	yes	all
1LS400-D1X	1LT400-D1X	N/A	specify	-	6-rib	8-rib	ProFlow	included	included	included + 4-rib	included	12	-	all
1LS400-D1X-I	1LT400-D1X-I	N/A	specify	3"	6-rib	8-rib	ProFlow	included	included	included + 4-rib	included	12	yes	all
1LS400-P1R	1LT400-P1R	N/A	specify	-	6-rib	8-rib	ProFlow	included	included	included + 4-rib	included	12	-	all
1LS400-P1R-I	1LT400-P1R-I	N/A	specify	3"	6-rib	8-rib	ProFlow	included	included	included + 4-rib	included	12	yes	all
1LS400-F1D/F1A	1LT400-F1D/F1A	N/A	specify	-	6-rib	8-rib	Race Valve	included	included	included + 4-rib	included	12	-	all
1LS400-F1D-I/F1-I/F1A-I	1LT400-F1D-I/F1-I/F1A-I	N/A	specify	3"	6-rib	8-rib	Race Valve	included	included	included + 4-rib	included	12	yes	all
1LS400-F1A94/F1C/F1R	1LT400-F1A94/F1C/F1R	N/A	specify	-	6-rib	8-rib	Race Valve	included	included	included + 4-rib	included	12	-	all
1LS400-F1A94-I/F1C-I/F1R-I	1LT400-F1A94-I/F1C-I/F1R-I	N/A	specify	3.5"	6-rib	8-rib	Race Valve	included	included	included + 4-rib	included	12	yes	all
1LS400-103	1LT400-103	N/A	specify	-	6-rib	8-rib	Race Valve	included	included	included + 4-rib	included	12	-	all
1LS400-103-I	1LT400-103-I	N/A	specify	3.5"	6-rib	8-rib	Race Valve	included	included	included + 4-rib	included	12	yes	all
1LS400-F1X	1LT400-F1X	N/A	specify	-	6-rib	10-rib	Race Valve	included	included	included + 4-rib	included	12	-	all
1LS400-F1X-I	1LT400-F1X-I	N/A	specify	3.5"	6-rib	10-rib	Race Valve	included	included	included + 4-rib	included	12	yes	all
1LS400-F2	1LT400-F2	N/A	specify	-	6-rib	10-rib	Race Valve	included	included	included + 4-rib	included	12	-	all
1LS400-F2-I	1LT400-F2-I	N/A	specify	3.5"	6-rib	10-rib	Race Valve	included	included	included + 4-rib	included	12	yes	all

LS ENGINE SWAP FOOTNOTES (specific to above applications):

- LL1) Requires Innovators West P/N 844-10-rib or 843-8-rib, or ATI Performance Products Balancer p/n 917345 (8-rib) and p/n 917347X (10-rib)
- LL2) Pinning crank pulley is recommended
- LL3) Can be ordered without A/C
- LL4) Can be ordered without power steering
- LL5) Not available for LS7
- LL6) Not tall deck compatible
- LL7) Not compatible with VVT
- LL8) Confirm fitment and kit measurements at ProCharger.com



FOR MORE INFORMATION:
SCAN CODE WITH PHONE OR VISIT:
PROCHARGER.COM/LS-SERPENTINE-ACCESSORY-DRIVE-KIT

COMPATIBLE GM ACCESSORIES

Description	Part #	Manufacturer/Notes
A/C Compressor	SD-7B10	Sanden, 6-rib
Alternator	20881337	GM, 2007-2013
Power Steering Pump	6175AL	Tuff Stuff (or equivalent), GM Type 2
Reservoir	6175ARES	Required
Water Pump (supplied)		



LS CLASSIC SERPENTINE KITS (EFI AND CARBURETED)

Year	Part Number	Description	Boost Options	HP Gain	Intercooler	Price/MAP
specify	1LS100-P1SC1	High Output with P-1SC-1	specify	specify	-	\$5,198
specify	1LS100-P1SC1-I	High Output with Intercooled P-1SC-1	specify	specify	2 core (550 hp)	\$6,148
specify	1LS100-P1X	High Output with P-1X	specify	specify	-	\$5,448
specify	1LS100-P1X-I	High Output with Intercooled P-1X	specify	specify	2 core (550 hp)	\$6,348
specify	1LS100-D1SC	High Output with D-1SC	specify	specify	-	\$5,598
specify	1LS100-D1SC-I	High Output with Intercooled D-1SC	specify	specify	3 core (825 hp)	\$6,898
specify	1LS100-D1X	High Output with D-1X	specify	specify	-	\$5,848
specify	1LS100-D1X-I	High Output with Intercooled D-1X	specify	specify	3 core (825 hp)	\$7,048
specify	1LS100-F1D/F1/F1A	High Output with F-1D, F-1, or F-1A	specify	specify	-	\$6,848
specify	1LS100-F1D-I/F1-I/F1A-I	High Output with Intercooled F-1D, F-1, or F-1A	specify	specify	Sht mtl 3C (950 hp)	\$8,198
specify	1LS100-F1A94/F1C/F1R	High Output with F-1A-94, F-1C or F-1R	specify	specify	-	\$7,198
specify	1LS100-F1A94-I/F1C-I/F1R-I	High Output with Intercooled F-1A-94, F-1C or F-1R	specify	specify	Sht mtl 3C (1050 hp)	\$8,698

LS ENGINE SWAP COG RACE KITS (EFI AND CARBURETED)

Year	Part Number	Description	Boost Options	HP Gain	Intercooler	Price/MAP
specify	1LS200-F1D/F1/F1A	Cog Kit with F-1D, F-1, or F-1A	specify	specify	-	\$7,148
specify	1LS200-F1D-I/F1-I/F1A-I	Cog Kit with Intercooled F-1D, F-1, or F-1A	specify	specify	Sht mtl 3C (950 hp)	\$8,548
specify	1LS200-F1A94/F1C/F1R	Cog Kit with F-1A-94, F-1C or F-1R	specify	specify	-	\$7,548
specify	1LS200-F1A94-I/F1C-I/F1R-I	Cog Kit with Intercooled F-1A-94, F-1C or F-1R	specify	specify	Sht mtl 3C (1050 hp)	\$9,098
specify	1LS200-F1X	Cog Kit with F-1X	specify	specify	-	\$8,798
specify	1LS200-F1X-I	Cog Kit with Intercooled F-1X	specify	specify	Sht mtl 3C (1300 hp)	\$10,348
specify	1LS200-F2	Cog Kit with F-2	specify	specify	-	\$8,998
specify	1LS200-F2-I	Cog Kit with Intercooled F-2	specify	specify	Sht mtl 3C (1300 hp)	\$10,548

Type	Part Number Suffix	Description	Upgrade From	Requirements	Notes	Price/MAP
FINISH OPTIONS	add "B" to part #	Supercharger Finish: Black, max 9.75" housing	satin	max 9.75" housing	-	+\$295
	add "P" to part #	Supercharger Finish: Polished, max 9.75" housing	satin	max 9.75" housing	-	+\$400
	add "B" to part #	Supercharger Finish: Black, 10.5" housing	satin	10.5" housing	-	+\$395
	add "P" to part #	Supercharger Finish: Polished, 10.5" housing	satin	10.5" housing	-	+\$500
	add "BB" to part #	Supercharger Bracket Finish: Black	satin	-	includes tensioner	+\$225
	add "PB" to part #	Supercharger Bracket Finish: Polished	satin	-	includes tensioner	+\$325
	add "BAB" to part #	Alternator Bracket Finish: Black	satin	-	-	+\$400
	add "PAB" to part #	Alternator Bracket Finish: Polished	satin	-	-	+\$500
	add "BPB" to part #	Power Steering Bracket Finish: Black	satin	-	-	+\$300
	add "PPB" to part #	Power Steering Bracket Finish: Polished	satin	-	-	+\$400
KIT UPGRADES	add "H" to part #	Gears: Helical gerset for noise reduction	straight-cut	P- or D-series only	-	+\$110
	add "-12R" to part #	12-rib drive system upgrade	8-rib	serpentine only	-	+\$260
	add "ATIPP" to part #	ATI Performance Products Balancer Upgrade	-	-	P/N 918853	+\$550
	3GKMM-004	Crank Pin Kit	-	-	-	+\$109
	3LSAT-002	Alternator bracket with tensioner	-	-	-	+\$570
	3LSPS-001	Power steering bracket (requires GM pump, #21997867)	-	-	-	+\$255
	3LSPS-002	Power steering delete bracket	-	-	-	+\$225
	AV008A-001	ProFlow Blow-off Valve (specify red or black)	-	-	-	+\$268
	add "BV" to part #	Bullet Blow-off Valve Upgrade (black only)	ProFlow	-	-	+\$125
	add "-RVR" or "RVB"	Race Blow-off Valve Upgrade (specify open or closed, alum or steel, red or blk)	ProFlow	-	-	+\$295
INTERCOOLERS	SEE PAGES 94-95 FOR INTERCOOLER UPGRADE AND INTAKE MANIFOLD OPTIONS AND DIMENSIONS					

SPECIFICATIONS

LS CLASSIC SERPENTINE SPECIFICATIONS

Year	Part Number	Stock HP	HP Gain	Tube Diam	Carb Hat	Drive System	Blow-off Valve	Power Steering Bracket (optional)	Alternator Bracket (optional)	SC Warranty (in months)	Tubing Supplied	Foot Notes
specify	1LS100-P1SC1	N/A	specify	-	optional	8-rib	ProFlow	yes + 4-rib	yes + 6-rib	12	-	all
specify	1LS100-P1SC1-I	N/A	specify	3"	optional	8-rib	ProFlow	yes + 4-rib	yes + 6-rib	12	yes	all
specify	1LS100-P1X	N/A	specify	-	optional	8-rib	ProFlow	yes + 4-rib	yes + 6-rib	12	-	all
specify	1LS100-P1X-I	N/A	specify	3"	optional	8-rib	ProFlow	yes + 4-rib	yes + 6-rib	12	yes	all
specify	1LS100-D1SC	N/A	specify	-	optional	8-rib	ProFlow	yes + 4-rib	yes + 6-rib	12	-	all
specify	1LS100-D1SC-I	N/A	specify	3"	optional	8-rib	ProFlow	yes + 4-rib	yes + 6-rib	12	yes	all
specify	1LS100-D1X	N/A	specify	-	optional	8-rib	ProFlow	yes + 4-rib	yes + 6-rib	12	-	all
specify	1LS100-D1X-I	N/A	specify	3"	optional	8-rib	ProFlow	yes + 4-rib	yes + 6-rib	12	yes	all
specify	1LS100-F1D/F1/F1A	N/A	specify	-	optional	8-rib	Race Valve	yes + 4-rib	yes + 6-rib	12	-	all
specify	1LS100-F1D-I/F1-I/F1A-I	N/A	specify	3"	optional	8-rib	Race Valve	yes + 4-rib	yes + 6-rib	12	yes	all
specify	1LS100-F1A94/F1C/F1R	N/A	specify	-	optional	8-rib	Race Valve	yes + 4-rib	yes + 6-rib	12	-	all
specify	1LS100-F1A94-I/F1C-I/F1R-I	N/A	specify	3.5"	optional	8-rib	Race Valve	yes + 4-rib	yes + 6-rib	12	yes	all

LS ENGINE SWAP COG RACE SPECIFICATIONS

Year	Part Number	Stock HP	HP Gain	Tube Diam	Carb Hat	Drive System	Blow-off Valve	Power Steering Bracket (optional)	Alternator Bracket (optional)	SC Warranty (in months)	Tubing Supplied	Foot Notes
specify	1LS200-F1D/F1/F1A	N/A	specify	-	optional	8 x 50 mm cog	Race Valve	yes + 4-rib	yes + 6-rib	Limited	-	all
specify	1LS200-F1D-I/F1-I/F1A-I	N/A	specify	3"	optional	8 x 50 mm cog	Race Valve	yes + 4-rib	yes + 6-rib	Limited	yes	all
specify	1LS200-F1A94/F1C/F1R	N/A	specify	-	optional	8 x 50 mm cog	Race Valve	yes + 4-rib	yes + 6-rib	Limited	-	all
specify	1LS200-F1A94-I/F1C-I/F1R-I	N/A	specify	3.5"	optional	8 x 50 mm cog	Race Valve	yes + 4-rib	yes + 6-rib	Limited	yes	all
specify	1LS200-F1X	N/A	specify	-	optional	8 x 50 mm cog	Race Valve	yes + 4-rib	yes + 6-rib	Limited	-	all
specify	1LS200-F1X-I	N/A	specify	3.5"	optional	8 x 50 mm cog	Race Valve	yes + 4-rib	yes + 6-rib	Limited	yes	all
specify	1LS200-F2	N/A	specify	-	optional	8 x 50 mm cog	Race Valve	yes + 4-rib	yes + 6-rib	Limited	-	all
specify	1LS200-F2-I	N/A	specify	3.5"	optional	8 x 50 mm cog	Race Valve	yes + 4-rib	yes + 6-rib	Limited	yes	all

LS ENGINE SWAP FOOTNOTES (specific to above applications):

- T1) Requires ATI Performance Products balancer (LS3/LS2/LS1 part #918853, LS7 part #918620) (not supplied - specify hardened hub)
- T2) Specify with or without power steering when using ProCharger Accessory Brackets
- T3) Pinning of the crank pulley is recommended
- T4) Compatible with mechanical or electric water pump; electric pump must have integrated idler pulley
- T5) Designed to work with Muscle Rods motor mounts or comparable (application dependent, sold separately by others)
- T6) Not compatible with Corvette-style water pump
- T7) Specify iron block, aluminum block and tall deck
- T8) LS7 engine requires modifications (not supplied)
- T9) Not a direct bolt-on for VVT engines

COMPATIBLE GM ACCESSORIES

Description	GM Part #	OEM Vehicle Source
A/C Compressor	92175482	1998-2002 LS1 F-Body
A/C Bracket	92066950	1998-2002 LS1 F-Body
A/C Belt	25-040430	Napa
A/C Belt Tensioner	12595289	- - -
Alternator	19244751	1999-2013 GM Truck 4.8/5.3/6.0
Power Steering Pump	21997867	2004-2007 Cadillac CTS
Power Steering Pulley	12568997	2004-2007 Cadillac CTS
Water Pump	89017593	1998-2002 LS1 F-Body

(Auto part stores can use these to cross reference other compatible brands)



LS REVERSE PASSENGER SIDE ENGINE SWAP KIT

Year	Part Number	Description	Boost Options	HP Gain	Intercooler	Price/MAP
specify	1GQ400-P1SC-1	High Output with P-1SC-1	specify	specify	-	\$5,198
specify	1GQ400-P1SC1-I	High Output with Intercooled P-1SC-1	specify	specify	2 core, 550hp	\$6,098
specify	1GQ400-D1SC	High Output with D-1SC	specify	specify	-	\$5,498
specify	1GQ400-D1SC-I	High Output with Intercooled D-1SC	specify	specify	3 core, 825hp	\$6,898
specify	1GQ400-F1D/F1/F1A	High Output with F-1D, F-1, or F-1A	specify	specify	-	\$6,798
specify	1GQ400-F1D-I/F1-I/F1A-I	High Output with Intercooled F-1D, F-1, or F-1A	specify	specify	3 core, 950hp	\$8,198
specify	1GQ400-F1A94/F1C/F1R	High Output with F-1A-94, F-1C or F-1R	specify	specify	-	\$7,148
specify	1GQ400-F1A94-I/F1C-I/F1R-I	High Output with Intercooled F-1A-94, F-1C or F-1R	specify	specify	3 core, 1050hp	\$8,648
specify	1GQ400-103	High Output with F-1R-103	specify	specify	-	\$8,198
specify	1GQ400-103-I	High Output with Intercooled F-1R-103	specify	specify	3 core, 1300hp	\$9,598
specify	1GQ400-F1X	High Output with F-1X	specify	specify	-	\$8,398
specify	1GQ400-F1X-I	High Output with Intercooled F-1X	specify	specify	3 core, 1300hp	\$9,898
specify	1GQ400-F2	High Output with F-2	specify	specify	-	\$8,598
specify	1GQ400-F2-I	High Output with Intercooled F-2	specify	specify	3 core 1300hp	\$10,098

LT1/LT4 CLASSIC SERPENTINE KITS (2014+)

Year	Part Number	Description	Boost Options	HP Gain	Intercooler	Price/MAP
specify	1LT100-P1SC1	High Output with P-1SC-1	specify	specify	-	\$5,098
specify	1LT100-P1SC1-I	High Output with Intercooled P-1SC-1	specify	specify	2 core, 550hp	\$6,098
specify	1LT100-D1SC	High Output with D-1SC	specify	specify	-	\$5,348
specify	1LT100-D1SC-I	High Output with Intercooled D-1SC	specify	specify	3 core, 825hp	\$6,748
specify	1LT100-F1D/F1/F1A	High Output with F-1D, F-1, or F-1A	specify	specify	-	\$6,498
specify	1LT100-F1D-I/F1-I/F1A-I	High Output with Intercooled F-1D, F-1, or F-1A	specify	specify	3 core, 950hp	\$7,898
specify	1LT100-F1A94/F1C/F1R	High Output with F-1A-94, F-1C or F-1R	specify	specify	-	\$6,898
specify	1LT100-F1A94-I/F1C-I/F1R-I	High Output with Intercooled F-1A-94, F-1C or F-1R	specify	specify	3 core, 1050hp	\$8,398
specify	1LT100-F1X	High Output with F-1X	specify	specify	-	\$7,348
specify	1LT100-F1X-I	High Output with Intercooled F-1X	specify	specify	3 core, 1300hp	\$8,848
specify	1LT100-F2	High Output with F-2	specify	specify	-	\$7,548
specify	1LT100-F2-I	High Output with Intercooled F-2	specify	specify	3 core, 1300hp	\$9,048

Type	Part Number Suffix	Description	Upgrade From	Requirements	Notes	Price/MAP
FINISH OPTIONS	add "-B" to part #	Supercharger Finish: Black, max 9.75" housing	satin	max 9.75" housing	-	+\$295
	add "-P" to part #	Supercharger Finish: Polished, max 9.75" housing	satin	max 9.75" housing	-	+\$400
	add "-B" to part #	Supercharger Finish: Black, 10.5" housing	satin	10.5" housing	-	+\$395
	add "-P" to part #	Supercharger Finish: Polished, 10.5" housing	satin	10.5" housing	-	+\$500
	add "-BB" to part #	Supercharger Bracket Finish: Black	satin	-	includes tensioner	+\$225
	add "-PB" to part #	Supercharger Bracket Finish: Polished	satin	-	includes tensioner	+\$325
SUPER-CHARGERS	add "-P1X" to part #	Supercharger Upgrade: P-1X	P-1SC-1	-	add'l 10-15+ hp	+\$250
	add "-P1R" to part #	Supercharger Upgrade: P-1R	P-1SC-1	-	-	+\$600
	add "-D1X" to part #	Supercharger Upgrade: D-1X	P-1SC-1	-	-	+\$500
KIT UPGRADES	add "-10R" to part #	10-rib drive system upgrade	8-rib	LS only	-	+\$360
	add "-H" to part #	Gears: Helical gearset for noise reduction	straight-cut	P- or D-series only	-	+\$110
	add "-BV" to part #	Bullet Blow-off Valve Upgrade (black only)	ProFlow	-	-	+\$125
	add "-RVR" or "RVB"	Race Blow-off Valve Upgrade (specify open or closed, alum or steel, red or blk)	ProFlow	-	-	+\$295
	add "-ATIPP" to part #	ATI Performance Products Balancer Upgrade	-	LT1 only	P/N 917314	+\$550
	3LTPS-001	Power steering bracket (requires GM Type II pump)	-	LT1 only	-	+\$255
	add "-BPP" to part #	Power Steering Bracket Finish: Black	satin	-	-	+\$300
	add "-PPB" to part #	Power Steering Bracket Finish: Polished	satin	-	-	+\$400
	3GKMM-004	Crank Pin Kit	-	LS only	-	+\$109
add "-ACD" to part #	Air Conditioning delete kit (required when running power steering)	-	LT1/LT4 only	7 psi max	+\$250	
INTERCOOLERS	SEE PAGES 94-95 FOR INTERCOOLER UPGRADE AND INTAKE MANIFOLD OPTIONS AND DIMENSIONS					

SPECIFICATIONS

LS REVERSE PASSENGER SIDE ENGINE SWAP KIT SPECIFICATIONS

Year	Part Number	Stock HP	HP Gain	Tube Diam	Carb Hat	Drive System	Blow-off Valve	Power Steering Bracket (optional)	SC Warranty (in months)	Tubing Supplied	Foot Notes
specify	1GQ400-P1SC1	N/A	specify	-	optional	8-rib	ProFlow	yes	12	-	U: 5, 7, 8, 9, 10, 11, 12
specify	1GQ400-P1SC1-I	N/A	specify	3"	optional	8-rib	ProFlow	yes	12	yes	U: 5, 7, 8, 9, 10, 11, 12
specify	1GQ400-D1SC	N/A	specify	-	optional	8-rib	ProFlow	yes	12	-	U: 5, 7, 8, 9, 10, 11, 12
specify	1GQ400-D1SC-I	N/A	specify	3"	optional	8-rib	ProFlow	yes	12	yes	U: 5, 7, 8, 9, 10, 11, 12
specify	1GQ400-F1D/F1/F1A	N/A	specify	-	optional	8-rib	Race Valve	yes	12	-	U: 5, 7, 8, 9, 10, 11, 12
specify	1GQ400-F1D-I/F1-I/F1A-I	N/A	specify	3"	optional	8-rib	Race Valve	yes	12	yes	U: 5, 7, 8, 9, 10, 11, 12
specify	1GQ400-F1A94/F1C/F1R	N/A	specify	-	optional	8-rib	Race Valve	yes	12	-	U: 5, 7, 8, 9, 10, 11, 12
specify	1GQ400-F1A94-I/F1C-I/F1R-I	N/A	specify	3.5"	optional	8-rib	Race Valve	yes	12	yes	U: 5, 7, 8, 9, 10, 11, 12
specify	1GQ400-103	N/A	specify	-	optional	8-rib	Race Valve	yes	12	-	U: 5, 7, 8, 9, 10, 11, 12
specify	1GQ400-103-I	N/A	specify	3.5"	optional	8-rib	Race Valve	yes	12	yes	U: 5, 7, 8, 9, 10, 11, 12
specify	1GQ400-F1X	N/A	specify	-	optional	8-rib	Race Valve	yes	12	-	U: 5, 7, 8, 9, 10, 11, 12
specify	1GQ400-F1X-I	N/A	specify	3.5"	optional	8-rib	Race Valve	yes	12	yes	U: 5, 7, 8, 9, 10, 11, 12
specify	1GQ400-F2	N/A	specify	-	optional	8-rib	Race Valve	yes	12	-	U: 5, 7, 8, 9, 10, 11, 12
specify	1GQ400-F2-I	N/A	specify	3.5"	optional	8-rib	Race Valve	yes	12	yes	U: 5, 7, 8, 9, 10, 11, 12

LT1/LT4 CLASSIC SERPENTINE (2014+) SPECIFICATIONS

Year	Part Number	Stock HP	HP Gain	Tube Diam	Carb Hat	Drive System	Blow-off Valve	Power Steering Bracket (optional)	SC Warranty (in months)	Tubing Supplied	Foot Notes
specify	1LT100-P1SC-1	N/A	specify	-	optional	8-rib	ProFlow	yes	12	-	U: 1, 2, 3, 4, 6, 7
specify	1LT100-P1SC1-I	N/A	specify	3"	optional	8-rib	ProFlow	yes	12	yes	U: 1, 2, 3, 4, 6, 7
specify	1LT100-D1SC	N/A	specify	-	optional	8-rib	ProFlow	yes	12	-	U: 1, 2, 3, 4, 6, 7
specify	1LT100-D1SC-I	N/A	specify	3"	optional	8-rib	ProFlow	yes	12	yes	U: 1, 2, 3, 4, 6, 7
specify	1LT100-F1D/F1/F1A	N/A	specify	-	optional	8-rib	Race Valve	yes	12	-	U: 1, 2, 3, 4, 6, 7
specify	1LT100-F1D-I/F1-I/F1A-I	N/A	specify	3"	optional	8-rib	Race Valve	yes	12	yes	U: 1, 2, 3, 4, 6, 7
specify	1LT100-F1A94/F1C/F1R	N/A	specify	-	optional	8-rib	Race Valve	yes	12	-	U: 1, 2, 3, 4, 6, 7
specify	1LT100-F1A94-I/F1C-I/F1R-I	N/A	specify	3.5"	optional	8-rib	Race Valve	yes	12	yes	U: 1, 2, 3, 4, 6, 7
specify	1LT100-F1X	N/A	specify	-	optional	8-rib	Race Valve	yes	12	-	U: 1, 2, 3, 4, 6, 7
specify	1LT100-F1X-I	N/A	specify	3.5"	optional	8-rib	Race Valve	yes	12	yes	U: 1, 2, 3, 4, 6, 7
specify	1LT100-F2	N/A	specify	-	optional	8-rib	Race Valve	yes	12	-	U: 1, 2, 3, 4, 6, 7
specify	1LT100-F2-I	N/A	specify	3.5"	optional	8-rib	Race Valve	yes	12	yes	U: 1, 2, 3, 4, 6, 7

LS/LT1/LT4 ENGINE SWAP FOOTNOTES (specific to above applications):

- U1) Comes with ProCharger 8-rib crank pulley, but is also compatible with ATI PP Super Damper (Part# 917314)
- U2) Works with OEM LT1 intake and ProCharger LT1/LT4 Sheet Metal Aluminum Intake Manifold
- U3) Uses all factory LT1 (Corvette) accessories
- U4) Factory power steering pump can be used with an attached fluid reservoir, remote reservoir recommended
- U5) Compatible with factory and most aftermarket A/C compressors
- U6) Specify LT1 or LT4 engine model
- U7) Specify wet or dry oil sump
- U8) 8-rib drive requires ATI PP bal #917345 (LSx, wet sump) or #918620 (LS7 dry sump - not supplied), or Innovator's West bal #843 (LS, wet sump) or #853 (LS7 dry sump) (not included - specify hardened hub)
- U9) Optional 10-rib requires ATI PP bal #917347X (LS, wet sump) (not supplied), or Innovator's West balancer #844 (LSx, wet sump) or #854 (LS7 dry sump), (not included - specify hardened hub)
- U10) May require water pump modification (optional water pump available from ProCharger)
- U11) LS passenger side uses factory C6 Corvette accessories
- U12) Factory iron block requires drilling and tapping for power steering



SBC/BBC SERPENTINE ACCESSORY DRIVE KIT (PROCHARGER OPTIONAL)

	Part Number SBC	Part Number BBC	Description	Boost Options	HP Gain	Intercooler	Price/MAP
	1CA300	1CB300	Serpentine Accessory Drive (with crank pulley + alternator bracket)	-	-	-	\$2,298
	1CA300-PS	1CB300-PS	Serpentine Accessory Drive (with crank pulley + alternator bracket & p/s bracket)	-	-	-	\$2,598
	1CA300-AC	1CB300-AC	Serpentine Accessory Drive (with crank pulley + alternator bracket & a/c bracket)	-	-	-	\$2,498
	1CA300-PS-AC	1CB300-PS-AC	Serpentine Accessory Drive (with crank pulley + alt bracket, p/s bracket, a/c bracket)	-	-	-	\$2,798
SUPERCHARGER INCLUDED	1CA400-P1SC1	1CB400-P1SC1	Serpentine Accessory Drive Kit with P-1SC-1 (with all accessory brackets)	specify	specify	-	\$5,998
	1CA400-P1SC1-I	1CB400-P1SC1-I	Serpentine Accessory Drive Kit with Intercooled P-1SC-1 (with all acc brackets)	specify	specify	2 core 550 hp	\$6,898
	1CA400-P1X	1CB400-P1X	Serpentine Accessory Drive Kit with P-1X (with all accessory brackets)	specify	specify	-	\$6,248
	1CA400-P1X-I	1CB400-P1X-I	Serpentine Accessory Drive Kit with Intercooled P-1X (with all accessory brackets)	specify	specify	2 core 550 hp	\$7,148
	1CA400-D1SC	1CB400-D1SC	Serpentine Accessory Drive Kit with D-1SC (with all accessory brackets)	specify	specify	-	\$6,298
	1CA400-D1SC-I	1CB400-D1SC-I	Serpentine Accessory Drive Kit with Intercooled D-1SC (with all accessory brackets)	specify	specify	3 core 825 hp	\$7,698
	1CA400-D1X	1CB400-D1X	Serpentine Accessory Drive Kit with D-1X (with all accessory brackets)	specify	specify	-	\$6,498
	1CA400-D1X-I	1CB400-D1X-I	Serpentine Accessory Drive Kit with Intercooled D-1X (with all acc brackets)	specify	specify	3 core 825 hp	\$7,698
	1CA400-P1R	1CB400-P1R	Serpentine Accessory Drive Kit with P-1R (with all accessory brackets)	specify	specify	-	\$6,598
	1CA400-P1R-I	1CB400-P1R-I	Serpentine Accessory Drive Kit with Intercooled P-1R (with all accessory brackets)	specify	specify	3 core 825 hp	\$7,798
	1CA400-F1D/F1A	1CB400-F1D/F1A	Serpentine Accessory Drive Kit with F-1D, F-1, or F-1A (with all accessory brackets)	specify	specify	-	\$7,448
	1CA400-F1D-I/F1A-I	1CB400-F1D-I/F1A-I	Serpentine Accessory Drive Kit with Intercooled F-1D, F-1, or F-1A (w/p, all acc brackets)	specify	specify	3 core 950 hp	\$8,798
	1CA400-F1A94/F1C/F1R	1CB400-F1A94/F1C/F1R	Serpentine Accessory Drive Kit with F-1A-94, F-1C or F-1R (with all accessory brackets)	specify	specify	-	\$7,798
	1CA400-F1A94-I/F1C-I/F1R-I	1CB400-F1A94-I/F1C-I/F1R-I	Serpentine Accessory Drive Kit with Intercooled F-1A-94, F-1C or F-1R (w/p, all acc brackets)	specify	specify	3 core 1050 hp	\$9,398
	1CA400-103	1CB400-103	Serpentine Accessory Drive Kit with F-1R-103 (with all accessory brackets)	specify	specify	-	\$8,948
	1CA400-103-I	1CB400-103-I	Serpentine Accessory Drive Kit with Intercooled F-1R-103 (with all accessory brackets)	specify	specify	3 core 1300 hp	\$10,498
	1CA400-F1X	1CB400-F1X	Serpentine Accessory Drive Kit with F-1X (10-rib) (with all accessory brackets)	specify	specify	-	\$9,448
	1CA400-F1X-I	1CB400-F1X-I	Serpentine Accessory Drive Kit with Intercooled F-1X (10-rib) with all acc brackets)	specify	specify	3 core 1300 hp	\$10,948
	1CA400-F2	1CB400-F2	Serpentine Accessory Drive Kit with F-2 (10-rib) (with all accessory brackets)	specify	specify	-	\$9,648
	1CA400-F2-I	1CB400-F2-I	Serpentine Accessory Drive Kit with Intercooled F-2 (10-rib) (with all acc brackets)	specify	specify	3 core 1300 hp	\$11,148

Type	Part Number Suffix	Description	Upgrade From	Requirements	Notes	Price/MAP
ACCESSORIES	omit "OPB"	Omit power steering belt, bracket & pulley, satin finish	1CX400-PS	-	-	-\$300
	omit "OAB"	Omit air conditioning bracket & pulley, satin finish	1CX400-AC	-	-	-\$200
	3LSBB-006	Add ProCharger supercharger bracket 8-rib, tensioner & belt, satin finish	1CX300	-	-	+\$650
	GA100I-006	SBC Water Pump, satin finish	no Water Pump	-	-	+\$153
	GA100I-006B	SBC Water Pump, black finish	no Water Pump	-	-	+\$165
	GA100I-006P	SBC Water Pump, polished finish	no Water Pump	-	-	+\$208
	GA100I-007	BBC Water Pump, satin finish	no Water Pump	-	-	+\$320
	GA100I-007B/P	BBC Water Pump, black or polished finish	no Water Pump	-	-	+\$355
	GA100I-005	Add Alternator CS130 160AMP, satin finish	no Alternator	-	-	+\$295
	GA100I-005B/P	Add Alternator CS130 160AMP, black or polished finish	no Alternator	-	-	+\$365
	GA100I-001(B)	Add A/C Compressor Sanden SD-7B10, satin or black finish	no A/C	-	-	+\$260
	GA100I-001P	Add A/C Compressor Sanden SD-7B10, polished finish	no A/C	-	-	+\$502
	GA100I-002	Add Power Steering Pump GM Type 2, satin finish	no P/S	-	-	+\$160
	GA100I-002B/P	Add Power Steering Pump GM Type 2, black or polished finish	no P/S	-	-	+\$242
FINISH OPTIONS	add "B" to part #	Supercharger Finish: Black, max 9.75" housing	satin	max 9.75" housing	-	+\$295
	add "P" to part #	Supercharger Finish: Polished, max 9.75" housing	satin	max 9.75" housing	-	+\$400
	add "B" to part #	Supercharger Finish: Black, 10.5" housing	satin	10.5" housing	-	+\$395
	add "P" to part #	Supercharger Finish: Polished, 10.5" housing	satin	10.5" housing	-	+\$500
	add "BB" to part #	Supercharger Bracket Finish: Black	satin	-	-	+\$225
	add "PB" to part #	Supercharger Bracket Finish: Polished	satin	-	-	+\$325
	add "BA" to part #	Accessory Bracket Finish: Black	satin	-	-	+\$250
	add "PA" to part #	Accessory Bracket Finish: Polished	satin	-	-	+\$350
KIT UPGRADES	add "H" to part #	Gears: Helical gearset for noise reduction	straight-cut	P- or D-series only	-	+\$110
	add "BV" to part #	Bullet Blow-off Valve Upgrade (black only)	ProFlow	-	-	+\$125
	add "RVR" or "RVB"	Race Blow-off Valve Upgrade (specify open or closed, alum or steel, red or blk)	ProFlow	-	-	+\$295
INTERCOOLERS	SEE PAGES 94-95 FOR INTERCOOLER UPGRADE AND INTAKE MANIFOLD OPTIONS AND DIMENSIONS					
CARB HATS	SEE PAGE 95 FOR CARB HAT OPTIONS					

SPECIFICATIONS

SBC/BBC SERPENTINE ACCESSORY DRIVE KIT SPECIFICATIONS

Part Number SBC	Part Number BBC	Stock HP	HP Gain	Tube Diam	Carb Hat	Drive System	Blow-off Valve	Water Pump	Alternator Bracket	Power Steering Bracket	Air Cond. Bracket	Supercharger Warranty (in months)	Tubing Supplied	Foot Notes
1CA300	1CB300	N/A	specify	-	optional	6-rib Acc Drive	-	-	included	included + 4-rib	-	-	-	all
1CA300-PS	1CB300-PS	N/A	specify	-	optional	6-rib Acc Drive	-	-	included	included + 4-rib	-	-	-	all
1CA300-AC	1CB300-AC	N/A	specify	-	optional	6-rib Acc Drive	-	-	included	-	included	-	-	all
1CA300-PS-AC	1CB300-PS-AC	N/A	specify	-	optional	6-rib Acc Drive	-	-	included	included + 4-rib	included	-	-	all
1CA400-P1SC1	1CB400-P1SC1	N/A	specify	-	optional	6-rib / 8-rib	ProFlow	-	included	included + 4-rib	included	12	-	all
1CA400-P1SC1-1	1CB400-P1SC1-1	N/A	specify	3"	optional	6-rib / 8-rib	ProFlow	-	included	included + 4-rib	included	12	yes	all
1CA400-P1X	1CB400-P1X	N/A	specify	-	optional	6-rib / 8-rib	ProFlow	-	included	included + 4-rib	included	12	-	all
1CA400-P1X-I	1CB400-P1X-I	N/A	specify	3"	optional	6-rib / 8-rib	ProFlow	-	included	included + 4-rib	included	12	yes	all
1CA400-D1SC	1CB400-D1SC	N/A	specify	-	optional	6-rib / 8-rib	ProFlow	-	included	included + 4-rib	included	12	-	all
1CA400-D1SC-I	1CB400-D1SC-I	N/A	specify	3"	optional	6-rib / 8-rib	ProFlow	-	included	included + 4-rib	included	12	yes	all
1CA400-D1X	1CB400-D1X	N/A	specify	-	optional	6-rib / 8-rib	ProFlow	-	included	included + 4-rib	included	12	-	all
1CA400-D1X-I	1CB400-D1X-I	N/A	specify	3"	optional	6-rib / 8-rib	ProFlow	-	included	included + 4-rib	included	12	yes	all
1CA400-P1R	1CB400-P1R	N/A	specify	-	optional	6-rib / 8-rib	ProFlow	-	included	included + 4-rib	included	12	-	all
1CA400-P1R-I	1CB400-P1R-I	N/A	specify	3"	optional	6-rib / 8-rib	ProFlow	-	included	included + 4-rib	included	12	yes	all
1CA400-F1D/F1A	1CB400-F1D/F1A	N/A	specify	-	optional	6-rib / 8-rib	Race Valve	-	included	included + 4-rib	included	12	-	all
1CA400-F1D-I/F1A-I	1CB400-F1D-I/F1A-I	N/A	specify	3"	optional	6-rib / 8-rib	Race Valve	-	included	included + 4-rib	included	12	yes	all
1CA400-F1A94/F1C/F1R	1CB400-F1A94/F1C/F1R	N/A	specify	-	optional	6-rib / 8-rib	Race Valve	-	included	included + 4-rib	included	12	-	all
1CA400-F1A94-I/F1C-I/F1R-I	1CB400-F1A94-I/F1C-I/F1R-I	N/A	specify	3"-3.5"	optional	6-rib / 8-rib	Race Valve	-	included	included + 4-rib	included	12	yes	all
1CA400-103	1CB400-103	N/A	specify	-	optional	6-rib / 8-rib	Race Valve	-	included	included + 4-rib	included	12	-	all
1CA400-103-I	1CB400-103-I	N/A	specify	3.5"	optional	6-rib / 8-rib	Race Valve	-	included	included + 4-rib	included	12	yes	all
1CA400-F1X	1CB400-F1X	N/A	specify	-	optional	6-rib / 10-rib	Race Valve	-	included	included + 4-rib	included	12	-	all
1CA400-F1X-I	1CB400-F1X-I	N/A	specify	3.5"	optional	6-rib / 10-rib	Race Valve	-	included	included + 4-rib	included	12	yes	all
1CA400-F2	1CB400-F2	N/A	specify	-	optional	6-rib / 10-rib	Race Valve	-	included	included + 4-rib	included	12	-	all
1CA400-F2-I	1CB400-F2-I	N/A	specify	3.5"	optional	6-rib / 10-rib	Race Valve	-	included	included + 4-rib	included	12	yes	all

SBC/BBC ACCESSORY DRIVE FOOTNOTES (specific to above applications):

- MM1) Uses factory balancer or aftermarket factory replacement
- MM2) Can be ordered without a/c
- MM3) Can be ordered without power steering



FOR MORE INFORMATION:
SCAN CODE WITH PHONE OR VISIT:
PROCHARGER.COM/SBC-BBC-ACCESSORY-DRIVE-KIT

COMPATIBLE GM ACCESSORIES

Description	Part #	Manufacturer/Notes
A/C Compressor	SD-7B10	Sanden, 6-rib
Alternator	CS130	6.14 center bolt spacing
Power Steering Pump	6175AL	Tuff Stuff (or equivalent), GM Type 2
Water Pump, SBC	8815	Edelbrock (or similar), 84-91 reverse rotation
Water Pump, BBC	8854	Edelbrock (or similar), GM Truck



SBC/BBC CLASSIC SERPENTINE BLOWER KITS (V-BELT ACCESSORIES)

Part Number SBC	Part Number BBC	Description	Boost Options	HP Gain	Intercooler	Price/MAP
1CA100-P600B*	1CB100-P600B*	High Output with P600B (8-rib)	specify	specify	-	\$3,998
1CA100-P1SC*	1CB100-P1SC*	High Output with P-1SC (8-rib)	specify	specify	-	\$4,548
1CA100-P1SC-I*	1CB100-P1SC-I*	High Output Intercooled with P-1SC (8-rib)	specify	specify	2 core, 550hp	\$5,698
1CA100-D1*	1CB100-D1*	High Output with D-1 (12-rib)	specify	specify	-	\$5,298
1CA100-D1SC*	1CB100-D1SC*	High Output with D-1SC (12-rib)	specify	specify	-	\$5,298
1CA100-D1SC-I*	1CB100-D1SC-I*	High Output Intercooled with D-1SC (12-rib)	specify	specify	3 core, 825hp	\$6,798
1CA100-F1D/F1/F1A*	1CB100-F1D/F1/F1A*	High Output with F-1D, F-1, F-1A (12-rib)	specify	specify	-	\$6,498
1CA100-F1D-I/F1-I/F1A-I*	1CB100-F1D-I/F1-I/F1A-I*	High Output Intercooled with F-1D, F-1, F-1A (12-rib)	specify	specify	3 core, 950hp	\$7,998
1CA100-F1A94/F1C/F1R*	1CB100-F1A94/F1C/F1R*	High Output with F-1A-94, F-1C, F-1R (12-rib)	specify	specify	-	\$6,898
1CA100-F1A94-I/F1C-I/F1R-I*	1CB100-F1A94-I/F1C-I/F1R-I*	High Output Intercooled with F-1A-94, F-1C, F-1R (12-rib)	specify	specify	3 core, 1050hp	\$8,398
1CA100-F1X	1CB100-F1X	High Output with F-1X (12-rib)	specify	specify	-	\$7,298
1CA100-F1X-I*	1CB100-F1X-I*	High Output Intercooled with F-1X (12-rib)	specify	specify	3 core, 1300hp	\$9,198
1CA100-F2*	1CB100-F2*	High Output with F-2 (12-rib)	specify	specify	-	\$7,598
1CA100-F2-I*	1CB100-F2-I*	High Output Intercooled with F-2 (12-rib)	specify	specify	3 core, 1300hp	\$9,498

Type	Part Number Suffix	Description	Upgrade From	Requirements	Notes	Price/MAP
FINISH OPTIONS	add "B" to part #	Supercharger Finish: Black, max 9.75" housing	satin	max 9.75" housing	excludes P600B	+\$295
	add "P" to part #	Supercharger Finish: Polished, max 9.75" housing	satin	max 9.75" housing	excludes P600B	+\$400
	add "B" to part #	Supercharger Finish: Black, 10.5" housing	satin	10.5" housing	-	+\$395
	add "P" to part #	Supercharger Finish: Polished, 10.5" housing	satin	10.5" housing	-	+\$500
	add "BB" to part #	Supercharger Bracket Finish: Black	satin	-	includes tensioner	+\$225
	add "PB" to part #	Supercharger Bracket Finish: Polished	satin	-	includes tensioner	+\$325
	add "BSB" to part #	Accessory Drive Bracket Finish: Black	satin	-	-	+\$200
add "PSB" to part #	Accessory Drive Bracket Finish: Polished	satin	-	-	+\$275	
SUPERCHARGERS	add "P1X" to part #	Supercharger Upgrade: P-1X	P-1SC	-	-	+\$500
	add "P1R" to part #	Supercharger Upgrade: P-1R	P-1SC	-	-	+\$800
	add "D1SC" to part #	Supercharger Upgrade: D-1SC	P-1SC	-	-	+\$525
	add "D1X" to part #	Supercharger Upgrade: D-1X	P-1SC	-	-	+\$700
	add "D1X" to part #	Supercharger Upgrade: D-1X	D-1SC	-	-	+\$200
CARB HATS	add "CB" to part #	Carb Hat Upgrade: Competition 4150 (at time of purchase)	standard	-	3.5" inlet, 4.5" height	+\$250
	add "CB" to part #	Carb Hat Upgrade: Competition 4150 (at time of purchase)	low profile	-	3.5" inlet, 4.5" height	+\$72
	add "BC" to part #	Carb Hat Finish: Black	satin	-	-	+\$100
	add "PC" to part #	Carb Hat Finish: Polished	satin	-	-	+\$150
KIT UPGRADES	1CXX10-SCA*	Serpentine Accessory Drive SBC/BBC (time of purchase)	-	req Sanden A/C	see footnote #8	+\$915
	1CXX10-SC*	Serpentine Accessory Drive SBC/BBC (time of purchase)	-	without A/C	see footnote #8	+\$915
	add "H" to part #	Gears: Helical gearset for noise reduction	straight-cut	P- or D-series only	-	+\$110
	AV008A-001	ProFlow Blow-off Valve (specify red or black)	-	-	-	+\$268
	AV006A-003	Bullet Blow-off Valve (specify open or closed)	-	-	-	+\$388
	3FASS-00X	Race Blow-off Valve (specify open or closed, alum or steel, red or black)	-	-	-	+\$498
	AB00XX-000	SBC/BBC P/S relocation kit (remote reservoir, pump not included (v-belt))	-	-	-	+\$298
AB007A-085	SBC Repositioning bracket	-	-	fits up tru F-2	+\$109	
AB008A-065	BBC Repositioning bracket	-	-	fits up tru F-2	+\$109	
INTERCOOLERS	SEE PAGES 94-95 FOR INTERCOOLER UPGRADE AND INTAKE MANIFOLD OPTIONS AND DIMENSIONS					

OPTIONS FOR THIS PAGE

SPECIFICATIONS

SBC/BBC SERPENTINE BLOWER KIT (V-BELT ACCESSORIES) SPECIFICATIONS

Part Number SBC	Part Number BBC	Stock HP	HP Gain	Tube Diam	Carb Hat	Drive System	Blow-off Valve	Power Steering Relocation Kit (optional)	A/C Installation Kit (serp only)	SC Warranty (in months)	Tubing Supplied	Foot Notes
1CA100-P600B*	1CB100-P600B*	N/A	specify	-	low profile	add'l 8-rib	Sold separately	Remote Reservoir	Yes	12	-	R: 1, 2, 3, 6, 7, 8
1CA100-P1SC*	1CB100-P1SC*	N/A	specify	-	low profile	add'l 8-rib	Sold separately	Remote Reservoir	Yes	12	-	R: 1, 2, 3, 6, 7, 8
1CA100-P1SC-I*	1CB100-P1SC-I*	N/A	specify	3"	std	add'l 8-rib	ProFlow	Remote Reservoir	Yes	12	Yes	R: 1, 2, 4, 6, 7, 8
1CA100-D1*	1CB100-D1*	N/A	specify	-	std	add'l 12-rib	Sold separately	Remote Reservoir	Yes	12	-	R: 1, 2, 3, 6, 7, 8
1CA100-D1SC*	1CB100-D1SC*	N/A	specify	-	std	add'l 12-rib	Sold separately	Remote Reservoir	Yes	12	-	R: 1, 2, 3, 6, 7, 8
1CA100-D1SC-I*	1CB100-D1SC-I*	N/A	specify	3"	std	add'l 12-rib	ProFlow	Remote Reservoir	Yes	12	Yes	R: 1, 2, 4, 6, 7, 8
1CA100-F1D/F1/F1A*	1CB100-F1D/F1/F1A*	N/A	specify	-	std	add'l 12-rib	Race Valve	Remote Reservoir	Yes	12	-	R: 1, 2, 6, 7, 8
1CA100-F1D-I/F1-I/F1A-I*	1CB100-F1D-I/F1-I/F1A-I*	N/A	specify	3"	std	add'l 12-rib	Race Valve	Remote Reservoir	Yes	12	Yes	R: 1, 2, 4, 6, 7, 8
1CA100-F1A94/F1C/F1R*	1CB100-F1A94/F1C/F1R*	N/A	specify	-	std	add'l 12-rib	Race Valve	Remote Reservoir	Yes	12	-	R: 1, 2, 6, 7, 8
1CA100-F1A94-I/F1C-I/F1R-I*	1CB100-F1A94-I/F1C-I/F1R-I*	N/A	specify	3.5"	std	add'l 12-rib	Race Valve	Remote Reservoir	Yes	12	Yes	R: 1, 2, 4, 6, 7, 8
1CA100-F1X	1CB100-F1X	N/A	specify	-	std	add'l 12-rib	Race Valve	Remote Reservoir	Yes	12	-	R: 1, 2, 6, 7, 8
1CA100-F1X-I*	1CB100-F1X-I*	N/A	specify	3.5"	std	add'l 12-rib	Race Valve	Remote Reservoir	Yes	12	Yes	R: 1, 2, 4, 6, 7, 8
1CA100-F2*	1CB100-F2*	N/A	specify	-	std	add'l 12-rib	Race Valve	Remote Reservoir	Yes	12	-	R: 1, 2, 6, 7, 8
1CA100-F2-I*	1CB100-F2-I*	N/A	specify	3.5"	std	add'l 12-rib	Race Valve	Remote Reservoir	Yes	12	Yes	R: 1, 2, 4, 6, 7, 8

SBC/BBC SERPENTINE BLOWER FOOTNOTES (specific to above applications):

- R1) Carbureted systems require 4150 style or similar blow-through carburetor or efi throttle body (sold separately by others) and fuel system upgrade (sold by ProCharger and others)
- R2) Must provide own P/S pump with remote reservoir, GM Type II Pump (both Serpentine and V-Groove)
- R3) Purchase of bypass valve recommended above 8 psi, or with intercooler (sold separately by ProCharger)
- R4) Universal Tubing Kit included, not designed for a specific vehicle
- R5) Cog may be required above 1,000 hp
- R6) A/C option on serpentine accessory drive requires Sanden A/C compressor 508/SD5H14 (sold separately by others)
- R7) Water pump notes:
 - V-Groove accessory drive requires standard rotation, long water pump (SB and BB)
 - Serpentine accessory drive requires reverse rotation water pump
 - SB requires 1984-91 Corvette reverse rotation water pump (sold separately by others)
 - BB requires reverse rotation BB water pump (Edelbrock part #8854, sold separately by others)
- R8) Alternator placement with serpentine accessory drive is not compatible with some aftermarket EFI systems; designed to work with Delco style alternator with 6.61" center to center mounting



SBC/BBC COG BLOWER RACE KITS (V-BELT ACCESSORIES)

Part Number SBC	Part Number BBC	Description	Boost Options	HP Gain	Intercooler	Price/MAP
1CA200-F1D/F1A*	1CB200-F1D/F1A*	Cog Race Kit with F-1D, F-1, F-1A	specify	specify	-	\$6,748
1CA200-F1D-I/F1A-I*	1CB200-F1D-I/F1A-I*	Intercooled Cog Race Kit with F-1D, F-1, or F-1A	specify	specify	3 core, 950hp	\$8,148
1CA200-F1A94/F1C/F1R*	1CB200-F1A94/F1C/F1R*	Cog Race Kit with F-1A-94, F-1C, F-1R	specify	specify	-	\$7,248
1CA200-F1A94-I/F1C-I/F1R-I*	1CB200-F1A94-I/F1C-I/F1R-I*	Intercooled Cog Race Kit with F-1A-94, F-1C or F-1R	specify	specify	3 core, 1050hp	\$8,648
1CA200-103*	1CB200-103*	Cog Race Kit with F-1R-103	specify	specify	-	\$7,748
1CA200-103-I*	1CB200-103-I*	Intercooled Cog Race Kit with F-1R-103	specify	specify	3 core, 1300hp	\$9,598
1CA200-F1X*	1CB200-F1X*	Cog Race Kit with F-1X	specify	specify	-	\$7,948
1CA200-F1X-I*	1CB200-F1X-I*	Intercooled Cog Race Kit with F-1X	specify	specify	3 core, 1300hp	\$9,798
1CA200-F2*	1CB200-F2*	Cog Race Kit with F-2	specify	specify	-	\$8,048
1CA200-F2-I*	1CB200-F2-I*	Intercooled Cog Race Kit with F-2	specify	specify	3 core, 1300hp	\$9,908
1CA200-F3R-spec*	1CB200-F3R-spec*	Cog Race Kit with F-3R-112 (F-1X-12)	specify	specify	-	\$8,948
1CA200-F3R-spec*	1CB200-F3R-spec*	Cog Race Kit with F-3R-121	specify	specify	-	\$9,348
1CA200-F3R-spec*	1CB200-F3R-spec*	Cog Race Kit with F-3R-130 or -136	specify	specify	-	\$9,548
1CA200-F1XR*	1CB200-F1XR*	Reverse Rotation Cog Race Kit with F-1X	specify	specify	-	\$8,348
1CA200-F2R*	1CB200-F2R*	Reverse Rotation Cog Race Kit with F-2	specify	specify	-	\$8,448
1CA200-F3RR-spec*	1CB200-F3RR-spec*	Reverse Rotation Cog Race Kit with F-3R-121	specify	specify	-	\$10,048
1CA200-F3RR-spec*	1CB200-F3RR-spec*	Reverse Rotation Cog Race Kit with F-3R-130 or -136	specify	specify	-	\$10,348

Type	Part Number Suffix	Description	Upgrade	Requirements	Notes	Price/MAP
FINISH OPTIONS	add "-B" to part #	Supercharger Finish: Black, max 9.75" housing	satin	max 9.75" housing	-	+\$295
	add "-P" to part #	Supercharger Finish: Polished, max 9.75" housing	satin	max 9.75" housing	-	+\$400
	add "-B" to part #	Supercharger Finish: Black, 10.5" housing	satin	10.5" housing	-	+\$395
	add "-P" to part #	Supercharger Finish: Polished, 10.5" housing	satin	10.5" housing	-	+\$500
	add "-BB" to part #	Supercharger Bracket Finish: Black	satin	-	includes tensioner	+\$225
	add "-PB" to part #	Supercharger Bracket Finish: Polished	satin	-	includes tensioner	+\$325
	add "-BSB" to part #	Accessory Drive Bracket Finish: Black	satin	-	-	+\$200
	add "-PSB" to part #	Accessory Drive Bracket Finish: Polished	satin	-	-	+\$275
KIT UPGRADES	add "-102/106"	Supercharger Upgrade: F-3D-102/106	F-3R-112	-	-	-\$500
	3FASS-00X	Race Blow-off Valve (specify open or closed, alum or steel, red or black)	-	-	incl. in Race Kits	+\$498
	add "-PRV" to part #	ProRace Blow-off Valve Upgrade (specify red or black)	Race	-	v-band clamp	+\$270
	add "-PRV" to part #	ProRace Blow-off Valve (specify red or black)	-	-	v-band clamp	+\$768
	1CXX10-SCA*	Serpentine Accessory Drive SBC/BBC (time of purchase)	-	req Sanden A/C	see footnote #8	+\$915
	1CXX10-SC*	Serpentine Accessory Drive SBC/BBC (time of purchase)	-	without A/C	see footnote #8	+\$915
	AB00X-000	SBC/BBC P/S relocation kit (remote reservoir), pump not included (v-belt)	-	-	-	+\$298
AB007A-085	SBC Repositioning bracket	-	-	fits up tru F-2	+\$109	
AB008A-065	BBC Repositioning bracket	-	-	fits up tru F-2	+\$109	
CARB HATS	add "-CB" to part #	Carb Hat Upgrade: Competition 4150 (at time of purchase)	standard	-	3.5" inlet, 4.5" height	+\$50
	add "-BC" to part #	Carb Hat Finish: Black	satin	-	-	+\$100
	add "-PC" to part #	Carb Hat Finish: Polished	satin	-	-	+\$150
	add "-DCP" to part #	Carb Hat Upgrade: Competition 4500, polished finish (at time of purchase)	standard	-	5" inlet, 5.5" height	+\$150
	add "-DCB" to part #	Carb Hat Upgrade: Competition 4500, black finish (at time of purchase)	standard	-	5" inlet, 5.5" height	+\$266
	AM001A-001	Competition Carb Hat 4150, satin finish	-	-	3.5" inlet, 4.5" height	+\$292
	AM001A-002B	Competition Carb Hat 4500, black finish	-	-	5" inlet, 5.5" height	+\$508
AM001A-002P	Competition Carb Hat 4500, polished finish	-	-	5" inlet, 5.5" height	+\$468	
INTERCOOLERS	SEE PAGES 94-95 FOR INTERCOOLER UPGRADE AND INTAKE MANIFOLD OPTIONS AND DIMENSIONS					

FOR CRANKDRIVE AND RACEDRIVE DETAILS, VISIT PROCHARGER.COM
OR REQUEST PROCHARGER'S PARTS & RACING GUIDE (SEE PAGE 93)

SPECIFICATIONS

SBC/BBC COG BLOWER RACE KIT (V-BELT ACCESSORIES) SPECIFICATIONS

Part Number SBC	Part Number BBC	Stock HP	HP Gain	Tube Diam	Carb Hat	Drive System	Blow-off Valve	Power Steering Relocation Kit (optional)	A/C Installation Kit (serp only)	SC Warranty (in months)	Tubing Supplied	Foot Notes
1CA200-F1D/F1A*	1CB200-F1D/F1A*	N/A	specify	-	Standard	8 x 50 mm cog	Race Valve	Remote Reservoir	Yes	Limited	-	S: 1, 3, 4, 5, 6, 7
1CA200-F1D-I/F1A-I*	1CB200-F1D-I/F1A-I*	N/A	specify	3"	Standard	8 x 50 mm cog	Race Valve	Remote Reservoir	Yes	Limited	Yes	S: 1, 2, 3, 4, 5, 6, 7
1CA200-F1A94/F1C/F1R*	1CB200-F1A94/F1C/F1R*	N/A	specify	-	Standard	8 x 50 mm cog	Race Valve	Remote Reservoir	Yes	Limited	-	S: 1, 3, 4, 5, 6, 7
1CA200-F1A94-I/F1C-I/F1R-I*	1CB200-F1A94-I/F1C-I/F1R-I*	N/A	specify	3.5"	Standard	8 x 50 mm cog	Race Valve	Remote Reservoir	Yes	Limited	Yes	S: 1, 2, 3, 4, 5, 6, 7
1CA200-103*	1CB200-103*	N/A	specify	-	Standard	8 x 50 mm cog	Race Valve	Remote Reservoir	Yes	Limited	-	S: 1, 3, 4, 5, 6, 7
1CA200-103-I*	1CB200-103-I*	N/A	specify	3.5"	Standard	8 x 50 mm cog	Race Valve	Remote Reservoir	Yes	Limited	Yes	S: 1, 2, 3, 4, 5, 6, 7
1CA200-F1X*	1CB200-F1X*	N/A	specify	-	Standard	8 x 50 mm cog	Race Valve	Remote Reservoir	Yes	Limited	-	S: 1, 3, 4, 5, 6, 7
1CA200-F1X-I*	1CB200-F1X-I*	N/A	specify	3.5"	Standard	8 x 50 mm cog	Race Valve	Remote Reservoir	Yes	Limited	Yes	S: 1, 2, 3, 4, 5, 6, 7
1CA200-F2*	1CB200-F2*	N/A	specify	-	Standard	8 x 50 mm cog	Race Valve	Remote Reservoir	Yes	Limited	-	S: 1, 3, 4, 5, 6, 7
1CA200-F2-I*	1CB200-F2-I*	N/A	specify	3.5"	Standard	8 x 50 mm cog	Race Valve	Remote Reservoir	Yes	Limited	Yes	S: 1, 2, 3, 4, 5, 6, 7
1CA200-F3R-spec*	1CB200-F3R-spec*	N/A	specify	-	-	14 x 55 mm cog	ProRace Valve	-	-	Limited	-	-
1CA200-F3R-spec*	1CB200-F3R-spec*	N/A	specify	-	-	14 x 55 mm cog	ProRace Valve	-	-	Limited	-	-
1CA200-F3R-spec*	1CB200-F3R-spec*	N/A	specify	-	-	14 x 55 mm cog	ProRace Valve	-	-	Limited	-	-
1CA200-F1XR*	1CB200-F1XR*	N/A	specify	-	-	8 x 75 mm cog	Race Valve	-	-	Limited	-	-
1CA200-F2R*	1CB200-F2R*	N/A	specify	-	-	8 x 75 mm cog	Race Valve	-	-	Limited	-	-
1CA200-F3RR-spec*	1CB200-F3RR-spec*	N/A	specify	-	-	8 x 75 mm cog	ProRace Valve	-	-	Limited	-	-
1CA200-F3RR-spec*	1CB200-F3RR-spec*	N/A	specify	-	-	8 x 75 mm cog	ProRace Valve	-	-	Limited	-	-

SBC/BBC COG BLOWER FOOTNOTES (specific to above applications):

- S1) Carbureted systems require 4150 style or similar blow-through carburetor or efi throttle body (sold separately by others) and fuel system upgrade (sold by ProCharger and others)
- S2) Universal Intercooler Tubing Kit included, not designed for a specific vehicle
- S3) Electric water pump recommended with V-belt; Mechanical water pump recommended for Serpentine (must use short style pump)
- S4) Must provide own P/S pump with remote reservoir, GM Type II Pump (both Serpentine and V-Groove)
- S5) A/C option on serpentine accessory drive requires Sanden A/C compressor 508/SD5H14 (sold separately by others)
- S6) Water pump notes:
 - Serpentine accessory drive requires reverse rotation water pump
 - SB requires 1984-91 Corvette reverse rotation water pump (sold separately by others)
 - BB requires reverse rotation BB water pump (Edelbrock part #8854, sold separately by others)
- S7) Alternator placement with serpentine accessory drive is not compatible with some aftermarket EFI systems; designed to work with Delco style alternator with 6.61" center to center mounting



2011-23 DODGE CHALLENGER HEMI (6.4) SYSTEMS AND KITS

Year	Part Number	Description	Boost Options	HP Gain	Intercooler	Price/MAP
2015-23	1DG515-SCI	High Output Intercooled System with P-1SC-1	7 psi	200+/215+* hp	3 Core	\$8,598
2015-23	1DG505-SCI	High Output Intercooled Tuner Kit with P-1SC-1	specify	specify	3 Core	\$7,398
2015-23	1DG415-SCI	Stage II Intercooled System with P-1SC-1	7 psi	200+/215+* hp	3 Core	\$9,698
2015-23	1DG405-SCI	Stage II Intercooled Tuner Kit with P-1SC-1	specify	specify	3 Core	\$8,498
2011-14	1DG314-SCI	High Output Intercooled System with P-1SC-1	7 psi	200+ hp	3 Core	\$8,598
2011-14	1DG304-SCI	High Output Intercooled Tuner Kit with P-1SC-1	specify	specify	3 Core	\$7,398
2011-14	1DG214-SCI	Stage II Intercooled System with P-1SC-1	7 psi	200+ hp	3 Core	\$9,698
2011-14	1DG204-SCI	Stage II Intercooled Tuner Kit with P-1SC-1	specify	specify	3 Core	\$8,498

2011-23 DODGE CHALLENGER HEMI (5.7) SYSTEMS AND KITS

Year	Part Number	Description	Boost Options	HP Gain	Intercooler	Price/MAP
2015-23	1DF615-SCI	High Output Intercooled System with P-1SC-1	7 psi	160+ hp	3 Core	\$8,598
2015-23	1DF605-SCI	High Output Intercooled Tuner Kit with P-1SC-1	specify	specify	3 Core	\$7,398
2011-14	1DF414-SCI	High Output Intercooled System with P-1SC-1	7 psi	160+ hp	3 Core	\$8,598
2011-14	1DF404-SCI	High Output Intercooled Tuner Kit with P-1SC-1	specify	specify	3 Core	\$7,398

2015-23 DODGE CHALLENGER V6 (3.6) SYSTEMS AND KITS

Year	Part Number	Description	Boost Options	HP Gain	Intercooler	Price/MAP
2015-23	1DQ214-SCI	High Output Intercooled System with P-1SC-1	7 psi	40-45%+	3 Core	\$7,598
2015-23	1DQ204-SCI	High Output Intercooled Tuner Kit with P-1SC-1	specify	specify	3 Core	\$6,448

Applications	Part Number Suffix	Description	Upgrade	Requirements	Notes	Price/MAP
ALL	add "-B" to part #	Supercharger Finish: Black, max 9.75" housing	satin	max 9.75" housing	-	+\$295
	add "-P" to part #	Supercharger Finish: Polished, max 9.75" housing	satin	max 9.75" housing	-	+\$400
	add "-BB" to part #	Supercharger Bracket Finish: Black	satin	-	-	+\$225
	add "-PB" to part #	Supercharger Bracket Finish: Polished	satin	-	-	+\$325
	add "-H" to part #	Gears: Helical gearset for noise reduction	straight-cut	P- or D-series only	-	+\$110
	add "-MS" to part #	MAP sensor adaptor bag	-	Tuner Kits only	-	+\$199
6.4L & 5.7L ONLY	add "-P1X" to part #	Supercharger Upgrade: P-1X	P-1SC-1	-	add'l 10-15+ hp	+\$250
	add "-P1R" to part #	Supercharger Upgrade: P-1R	P-1SC-1	Tuner Kits only	-	+\$600
	add "-D1SC" to part #	Supercharger Upgrade: D-1SC	P-1SC-1	Tuner Kits only	-	+\$300
	add "-D1X" to part #	Supercharger Upgrade: D-1X	P-1SC-1	Tuner Kits only	-	+\$500
	add "-D" or "-1" or "-A"	Supercharger Upgrade: F-1D, F-1, F-1A	P-1SC-1	Tuner Kits only	-	+\$900
	add "-94" or "-C" or "-R"	Supercharger Upgrade: F-1A-94, F-1C or F-1R	P-1SC-1	Tuner Kits only	-	+\$1,250
	add "-103" to part #	Supercharger Upgrade: F-1R-103	P-1SC-1	Tuner Kits only	-	+\$2,300
	add "-Race" to part #	Intercooler Upgrade: Race air-to-air, 1000 HP max	3-core	Tuner Kits only	-	+\$435
	add "-BI" to part #	Intercooler Finish: Black	raw	Race IC only	-	+\$195
	add "-RVR" or "RVB"	Race Blow-off Valve Upgrade (specify open or closed, alum or steel, red or blk)	ProFlow	-	-	+\$295
	add "-ATIPP" to part #	ATI Performance Products Balancer Upgrade	-	6.4L only	-	+\$550
	add "-FP" to part #	In-Tank Fuel Pump	-	Tuner Kits only	-	+\$550

SPECIFICATIONS

2011-23 DODGE CHALLENGER HEMI (6.4) SPECIFICATIONS

Year	Part Number	OEM hp Rating	HP Gain	Tube Diam	IC Mount	Drive System	Blow-off System	Fuel System Upgrade	Fuel Inj. Supplied	Computer/Ignition Modifications	SC Warranty (in months)	CARB E.O.	Foot Notes
2015-23	1DG515-SCI	485	200+/215+* hp	3"	V	stk 6-rib	ProFlow	MAP sensor, pump/booster	52 lbs/hr	programmer supplied	12, 36 opt. (\$99)	D-365-35 (15-22)	V: 1, 4, 7, 8, 9, 11, 12
2015-23	1DG505-SCI	485	specify	3"	V	stk 6-rib	ProFlow	not supplied	No	not supplied	12	-	V: 1, 4, 7, 8, 9, 12
2015-23	1DG415-SCI	485	200+/215+* hp	3"	V	add'l 8-rib	ProFlow	MAP sensor, pump/booster	52 lbs/hr	programmer supplied	12, 36 opt. (\$99)	D-365-26 (15-20)	V: 1, 4, 6, 7, 8, 9, 11, 12
2015-23	1DG405-SCI	485	specify	3"	V	add'l 8-rib	ProFlow	not supplied	No	not supplied	12	-	V: 1, 4, 6, 7, 8, 9, 12
2011-14	1DG314-SCI	470	200+ hp	3"	V	stk 6-rib	ProFlow	MAP sensor, in-tank pump	52 lbs/hr	programmer supplied	12, 36 opt. (\$99)	D-365-22	V: 1, 4, 9, 12
2011-14	1DG304-SCI	470	specify	3"	V	stk 6-rib	ProFlow	not supplied	No	not supplied	12	-	V: 1, 4, 9, 12
2011-14	1DG214-SCI	470	200+ hp	3"	V	add'l 8-rib	ProFlow	MAP sensor, in-tank pump	52 lbs/hr	programmer supplied	12, 36 opt. (\$99)	D-365-22	V: 1, 4, 6, 9, 12
2011-14	1DG204-SCI	470	specify	3"	V	add'l 8-rib	ProFlow	not supplied	No	not supplied	12	-	V: 1, 4, 6, 9, 12

2011-23 DODGE CHALLENGER HEMI (5.7) SPECIFICATIONS

Year	Part Number	OEM hp Rating	HP Gain	Tube Diam	IC Mount	Drive System	Blow-off System	Fuel System Upgrade	Fuel Inj. Supplied	Computer/Ignition Modifications	SC Warranty (in months)	CARB E.O.	Foot Notes
2015-23	1DF615-SCI	375	160+ hp	3"	V	stk 6-rib	ProFlow	MAP sensor, in-tank pump	39.5 lbs/hr	programmer supplied	12, 36 opt. (\$99)	D-365-22 (15-19)	V: 1, 4, 7, 8, 9, 10, 12
2015-23	1DF605-SCI	375	specify	3"	V	stk 6-rib	ProFlow	not supplied	No	not supplied	12	-	V: 1, 4, 7, 9, 10, 12
2011-14	1DF414-SCI	375	160+ hp	3"	V	stk 6-rib	ProFlow	MAP sensor	39.5 lbs/hr	programmer supplied	12, 36 opt. (\$99)	D-365-22	V: 1, 4, 9, 10, 12
2011-14	1DF404-SCI	375	specify	3"	V	stk 6-rib	ProFlow	not supplied	No	not supplied	12	-	V: 1, 4, 9, 12

2015-23 DODGE CHALLENGER V6 (3.6) SPECIFICATIONS

Year	Part Number	OEM hp Rating	HP Gain	Tube Diam	IC Mount	Drive System	Blow-off System	Fuel System Upgrade	Fuel Inj. Supplied	Computer/Ignition Modifications	SC Warranty (in months)	CARB E.O.	Foot Notes
2015-23	1DQ214-SCI	292	40-45%+ hp	3"	V	add'l 6-rib	ProFlow	MAP sensor	50 lb/hr	programmer supplied	12, 36 opt. (\$99)	-	V: 1, 2, 4, 8, 10
2015-23	1DQ204-SCI	292	specify	3"	V	add'l 6-rib	ProFlow	not supplied	No	not supplied	12	-	V: 1, 4, 8, 10

* 215+ hp with HO Intercooled System and Race intercooler upgrade

DODGE AUTOMOTIVE FOOTNOTES (specific to above applications):

- V1) Model year must be specified
- V2) Due to variability among OEM computers, the prevalence of custom modifications, and age/miles/condition of vehicles, dyno tuning may be required
- V4) Specify manual or automatic transmission
- V6) Purchase of aftermarket balancer required, ATI PP part #918459 (not included - specify hardened hub)
- V7) Specify Shaker or standard hood
- V8) 2015+ vehicles require ECM unlock (call for details) - not included
- V9) Specify with or without strut bar
- V10) Specify 2WD or AWD
- V11) 2015-20 supplied with in-tank pump, 2021+ supplied with fuel pump booster
- V12) Race valve requires fabrication on aluminum plenum equipped applications



2008-10 DODGE CHALLENGER HEMI SRT8 (6.1) SYSTEMS AND KITS

Year	Part Number	Description	Boost Options	HP Gain	Intercooler	Price/MAP
2008-10	1DF314-SCI-6.1	High Output Intercooled System with P-1SC-1	7 psi	160+ hp	3 Core	\$8,298
2008-10	1DF304-SCI-6.1	High Output Intercooled Tuner Kit with P-1SC-1	specify	specify	3 Core	\$6,998
2008-10	1DF214-SCI-6.1	Stage II Intercooled System with P-1SC-1	7 psi	160+ hp	3 Core	\$9,498
2008-10	1DF204-SCI-6.1	Stage II Intercooled Tuner Kit with P-1SC-1	specify	specify	3 Core	\$8,198

2008-10 DODGE CHALLENGER HEMI R/T (5.7) SYSTEMS AND KITS

Year	Part Number	Description	Boost Options	HP Gain	Intercooler	Price/MAP
2008-10	1DF314-SCI-5.7	High Output Intercooled System with P-1SC-1	7 psi	130+ hp	3 Core	\$7,998
2008-10	1DF304-SCI-5.7	High Output Intercooled Tuner Kit with P-1SC-1	specify	specify	3 Core	\$6,998

OPTIONS FOR THIS PAGE	Applications	Part Number Suffix	Description	Upgrade From	Requirements	Notes	Price/MAP	
	ALL	add "-B" to part #		Supercharger Finish: Black, max 9.75" housing	satn	max 9.75" housing	-	+\$295
		add "-P" to part #		Supercharger Finish: Polished, max 9.75" housing	satn	max 9.75" housing	-	+\$400
		add "-BB" to part #		Supercharger Bracket Finish: Black	satn	HO only	-	+\$225
		add "-PB" to part #		Supercharger Bracket Finish: Polished	satn	HO only	-	+\$325
		add "-BST" to part #		Supercharger Bracket (Stage II) Finish: Black	satn	Stage II only	-	+\$375
		add "-PST" to part #		Supercharger Bracket (Stage II) Finish: Polished	satn	Stage II only	-	+\$475
		add "-P1X" to part #		Supercharger Upgrade: P-1X	P-1SC-1	-	add'l 10-15+ hp	+\$250
		add "-P1R" to part #		Supercharger Upgrade: P-1R	P-1SC-1	Tuner Kits only	-	+\$600
		add "-D1SC" to part #		Supercharger Upgrade: D-1SC	P-1SC-1	Tuner Kits only	-	+\$300
		add "-D1X" to part #		Supercharger Upgrade: D-1X	P-1SC-1	Tuner Kits only	-	+\$500
		add "-D" or "-1" or "-A"		Supercharger Upgrade: F-1D, F-1, F-1A	P-1SC-1	Tuner Kits only	-	+\$900
		add "-H" to part #		Gears: Helical gearset for noise reduction	straight-cut	P- or D-series only	-	+\$110
		add "-RVR" or "-RVB"		Race Blow-off Valve Upgrade (specify open or closed, alum or steel, red or blk)	ProFlow	-	-	+\$295
		6.1L ONLY	add "-MS" to part #		MAP sensor adaptor bag	-	Tuner Kits only	-
	add "-FP" to part #		In-Tank Fuel Pump	-	Tuner Kits only	-	+\$550	

SPECIFICATIONS

2008-10 DODGE CHALLENGER HEMI SRT8 (6.1) SPECIFICATIONS

Year	Part Number	OEM hp Rating	HP Gain	Tube Diam	IC Mount	Drive System	Blow-off System	Fuel System Upgrade	Fuel Inj. Supplied	Computer/Ignition Modifications	SC Warranty (in months)	CARB E.O.	Foot Notes
2008-10	1DF314-SCI	425	160+ hp	3"	V	stk 6-rib	ProFlow	MAP sensor, in-tank pump	39.5 lbs/hr	programmer supplied	12, 36 opt. (\$99)	D-365-7	W: 1, 3, 4, 8
2008-10	1DF304-SCI	425	specify	3"	V	stk 6-rib	ProFlow	not supplied	No	not supplied	12	-	W: 1, 3, 4, 8
2008-10	1DF214-SCI	425	160+ hp	3"	V	add'l 8-rib	ProFlow	MAP sensor, in-tank pump	39.5 lbs/hr	programmer supplied	12, 36 opt. (\$99)	-	W: 1, 2, 3, 4, 6, 7, 8
2008-10	1DF204-SCI	425	specify	3"	V	add'l 8-rib	ProFlow	not supplied	No	not supplied	12	-	W: 1, 3, 4, 6, 7, 8

2008-10 DODGE CHALLENGER HEMI R/T (5.7) SPECIFICATIONS

Year	Part Number	OEM hp Rating	HP Gain	Tube Diam	IC Mount	Drive System	Blow-off System	Fuel System Upgrade	Fuel Inj. Supplied	Computer/Ignition Modifications	SC Warranty (in months)	CARB E.O.	Foot Notes
2008-10	1DF314-SCI	370	130+ hp	3"	V	stk 6-rib	ProFlow	MAP sensor	39.5 lbs/hr	programmer supplied	12, 36 opt. (\$99)	D-365-7 (09-10)	W: 1, 3, 4, 8
2008-10	1DF304-SCI	370	specify	3"	V	stk 6-rib	ProFlow	not supplied	No	not supplied	12	-	W: 1, 3, 4, 8

DODGE AUTOMOTIVE FOOTNOTES (specific to above applications):

- W1) Model year must be specified
 W2) Due to variability among OEM computers, the prevalence of custom modifications, and age/miles/condition of vehicles, dyno tuning may be required
 W3) Specify engine size (5.7 or 6.1)
 W4) Specify manual or automatic transmission
 W6) Purchase of aftermarket balancer required (not included - specify hardened hub):
 5.7 (2008) = ATI PP part #918435
 5.7 (2009-10) = ATI PP part #918445
 6.1 = ATI PP part #918432
 W7) Special order kit: order form and non-refundable deposit required at time of order—may require additional lead time for processing
 W8) Race valve requires fabrication on aluminum plenum equipped applications

2011-23 DODGE CHALLENGER HEMI (6.4) SYSTEMS AND KITS

Year	Part Number	Description	Boost Options	HP Gain	Intercooler	Price/MAP
2015-23	1DG515-SCI	High Output Intercooled System with P-1SC-1	7 psi	200+/215+* hp	3 Core	\$8,598
2015-23	1DG505-SCI	High Output Intercooled Tuner Kit with P-1SC-1	specify	specify	3 Core	\$7,398
2015-23	1DG415-SCI	Stage II Intercooled System with P-1SC-1	7 psi	200+/215+* hp	3 Core	\$9,698
2015-23	1DG405-SCI	Stage II Intercooled Tuner Kit with P-1SC-1	specify	specify	3 Core	\$8,498
2011-14	1DG314-SCI	High Output Intercooled System with P-1SC-1	7 psi	200+ hp	3 Core	\$8,598
2011-14	1DG304-SCI	High Output Intercooled Tuner Kit with P-1SC-1	specify	specify	3 Core	\$7,398
2011-14	1DG214-SCI	Stage II Intercooled System with P-1SC-1	7 psi	200+ hp	3 Core	\$9,698
2011-14	1DG204-SCI	Stage II Intercooled Tuner Kit with P-1SC-1	specify	specify	3 Core	\$8,498

2011-23 DODGE CHALLENGER HEMI (5.7) SYSTEMS AND KITS

Year	Part Number	Description	Boost Options	HP Gain	Intercooler	Price/MAP
2015-23	1DF615-SCI	High Output Intercooled System with P-1SC-1	7 psi	160+ hp	3 Core	\$8,598
2015-23	1DF605-SCI	High Output Intercooled Tuner Kit with P-1SC-1	specify	specify	3 Core	\$7,398
2011-14	1DF414-SCI	High Output Intercooled System with P-1SC-1	7 psi	160+ hp	3 Core	\$8,598
2011-14	1DF404-SCI	High Output Intercooled Tuner Kit with P-1SC-1	specify	specify	3 Core	\$7,398

2015-23 DODGE CHALLENGER V6 (3.6) SYSTEMS AND KITS

Year	Part Number	Description	Boost Options	HP Gain	Intercooler	Price/MAP
2015-23	1DQ214-SCI	High Output Intercooled System with P-1SC-1	7 psi	40-45%+	3 Core	\$7,598
2015-23	1DQ204-SCI	High Output Intercooled Tuner Kit with P-1SC-1	specify	specify	3 Core	\$6,448

Applications	Part Number Suffix	Description	Upgrade	Requirements	Notes	Price/MAP
ALL	add "-B" to part #	Supercharger Finish: Black, max 9.75" housing	satin	max 9.75" housing	-	+\$295
	add "-P" to part #	Supercharger Finish: Polished, max 9.75" housing	satin	max 9.75" housing	-	+\$400
	add "-BB" to part #	Supercharger Bracket Finish: Black	satin	-	-	+\$225
	add "-PB" to part #	Supercharger Bracket Finish: Polished	satin	-	-	+\$325
	add "-H" to part #	Gears: Helical gearset for noise reduction	straight-cut	P- or D-series only	-	+\$110
	add "-MS" to part #	MAP sensor adaptor bag	-	Tuner Kits only	-	+\$199
6.4L & 5.7L ONLY	add "-P1X" to part #	Supercharger Upgrade: P-1X	P-1SC-1	-	add'l 10-15+ hp	+\$250
	add "-P1R" to part #	Supercharger Upgrade: P-1R	P-1SC-1	Tuner Kits only	-	+\$600
	add "-D1SC" to part #	Supercharger Upgrade: D-1SC	P-1SC-1	Tuner Kits only	-	+\$300
	add "-D1X" to part #	Supercharger Upgrade: D-1X	P-1SC-1	Tuner Kits only	-	+\$500
	add "-D" or "-1" or "-A"	Supercharger Upgrade: F-1D, F-1, F-1A	P-1SC-1	Tuner Kits only	-	+\$900
	add "-94" or "-C" or "-R"	Supercharger Upgrade: F-1A-94, F-1C or F-1R	P-1SC-1	Tuner Kits only	-	+\$1,250
	add "-103" to part #	Supercharger Upgrade: F-1R-103	P-1SC-1	Tuner Kits only	-	+\$2,300
	add "-Race" to part #	Intercooler Upgrade: Race air-to-air, 1000 HP max	3-core	Tuner Kits only	-	+\$435
	add "-BI" to part #	Intercooler Finish: Black	raw	Race IC only	-	+\$195
	add "-RVR" or "RVB"	Race Blow-off Valve Upgrade (specify open or closed, alum or steel, red or blk)	ProFlow	-	-	+\$295
	add "-ATIPP" to part #	ATI Performance Products Balancer Upgrade	-	6.4L only	-	+\$550
	add "-FP" to part #	In-Tank Fuel Pump	-	Tuner Kits only	-	+\$550

SPECIFICATIONS

2012-23 DODGE CHARGER HEMI SRT8 (6.4) SPECIFICATIONS

Year	Part Number	OEM hp Rating	HP Gain	Tube Diam	Intercooler Mount	Drive System	Blow-off System	Fuel System Upgrade	Fuel Inj. Supplied	Computer/Ignition Modifications	SC Warranty (in months)	CARB E.O.	Foot Notes
2015-23	1DI515-SCI	485	200+/215+* hp	3"	V	stk 6-rib	ProFlow	MAP sensor, pump/booster	52 lbs/hr	programmer supplied	12, 36 opt. (\$99)	D-365-35 (15-22)	X: 1, 4, 7, 8
2015-23	1DI505-SCI	485	specify	3"	V	stk 6-rib	ProFlow	not supplied	No	not supplied	12	-	X: 1, 4, 7, 8
2015-23	1DI415-SCI	485	200+/215+* hp	3"	V	add'l 8-rib	ProFlow	MAP sensor, pump/booster	52 lbs/hr	programmer supplied	12, 36 opt. (\$99)	-	X: 1, 2, 4, 6, 7, 8
2015-23	1DI405-SCI	485	specify	3"	V	add'l 8-rib	ProFlow	not supplied	No	not supplied	12	-	X: 1, 4, 6, 8
2012-14	1DI314-SCI	470	200+ hp	3"	V	stk 6-rib	ProFlow	MAP sensor, in-tank pump	52 lbs/hr	programmer supplied	12, 36 opt. (\$99)	D-365-22	X: 1, 4, 8
2012-14	1DI304-SCI	470	specify	3"	V	stk 6-rib	ProFlow	not supplied	No	not supplied	12	-	X: 1, 4, 8

2011-23 DODGE CHARGER HEMI R/T (5.7) SPECIFICATIONS

Year	Part Number	OEM hp Rating	HP Gain	Tube Diam	Intercooler Mount	Drive System	Blow-off System	Fuel System Upgrade	Fuel Inj. Supplied	Computer/Ignition Modifications	SC Warranty (in months)	CARB E.O.	Foot Notes
2015-23	1DI615-SCI	375	160+ hp	3"	V	stk 6-rib	ProFlow	MAP sensor, in-tank pump	39.5 lbs/hr	programmer supplied	12, 36 opt. (\$99)	D-365-22 (15-19)	X: 1, 4, 5, 8
2015-23	1DI605-SCI	375	specify	3"	V	stk 6-rib	ProFlow	not supplied	No	not supplied	12	-	X: 1, 4, 5, 8
2011-14	1DI414-SCI	370	160+ hp	3"	V	stk 6-rib	ProFlow	MAP sensor	39.5 lbs/hr	programmer supplied	12, 36 opt. (\$99)	D-365-22	X: 1, 4, 8
2011-14	1DI404-SCI	370	specify	3"	V	stk 6-rib	ProFlow	not supplied	No	not supplied	12	-	X: 1, 4, 8

2015-22 DODGE CHARGER V6 (3.6) SPECIFICATIONS

Year	Part Number	OEM hp Rating	HP Gain	Tube Diam	Intercooler Mount	Drive System	Blow-off System	Fuel System Upgrade	Fuel Inj. Supplied	Computer/Ignition Modifications	SC Warranty (in months)	CARB E.O.	Foot Notes
2015-22	1DQ314-SCI	292	40-45%+ hp	3"	V	add'l 6-rib	ProFlow	MAP sensor	50 lb/hr	programmer supplied	12, 36 opt. (\$99)	-	X: 1, 2
2015-22	1DQ304-SCI	292	specify	3"	V	add'l 6-rib	ProFlow	not supplied	No	not supplied	12	-	X: 1

* 215+ hp with HO Intercooled System and Race intercooler upgrade

DODGE AUTOMOTIVE FOOTNOTES (specific to above applications):

- X1) Model year must be specified
- X2) Due to variability among OEM computers, the prevalence of custom modifications, and age/miles/condition of vehicles, dyno tuning may be required
- X4) Specify 2WD or AWD
- X5) 2015+ vehicles require ECM unlock (call for details) - not included
- X6) Purchase of aftermarket balancer required, ATI PP part #918459 (not included - specify hardened hub)
- X7) 2015-20 supplied with in-tank pump, 2021+ supplied with fuel pump booster
- X8) Race valve requires fabrication on aluminum plenum equipped applications



2006-10 DODGE CHARGER HEMI SRT8 (6.1) SYSTEMS AND KITS

Year	Part Number	Description	Boost Options	HP Gain	Intercooler	Price/MAP
2006-10	1DD314-SCI-6.1	High Output Intercooled System with P-1SC-1	7 psi	160+ hp	3 Core	\$8,298
2006-10	1DD304-SCI-6.1	High Output Intercooled Tuner Kit with P-1SC-1	specify	specify	3 Core	\$6,998
2006-10	1DD214-SCI-6.1	Stage II Intercooled System with P-1SC-1	7 psi	160+ hp	3 Core	\$9,498
2006-10	1DD204-SCI-6.1	Stage II Intercooled Tuner Kit with P-1SC-1	specify	specify	3 Core	\$8,198

2006-10 DODGE CHARGER HEMI R/T (5.7) SYSTEMS AND KITS

Year	Part Number	Description	Boost Options	HP Gain	Intercooler	Price/MAP
2006-10	1DD314-SCI-5.7	High Output Intercooled System with P-1SC-1	7 psi	110+/130+* hp	3 Core	\$7,998
2006-10	1DD304-SCI-5.7	High Output Intercooled Tuner Kit with P-1SC-1	specify	specify	3 Core	\$6,998
2006-08	1DD214-SCI-5.7	Stage II Intercooled System with P-1SC-1	7 psi	110+ hp	3 Core	\$9,198
2006-08	1DD204-SCI-5.7	Stage II Intercooled Tuner Kit with P-1SC-1	specify	specify	3 Core	\$8,198

Applications	Part Number Suffix	Description	Upgrade From	Requirements	Notes	Price/MAP
ALL	add "B" to part #	Supercharger Finish: Black, max 9.75" housing	satin	max 9.75" housing	-	+\$295
	add "P" to part #	Supercharger Finish: Polished, max 9.75" housing	satin	max 9.75" housing	-	+\$400
	add "BB" to part #	Supercharger Bracket Finish: Black	satin	HO only	-	+\$225
	add "PB" to part #	Supercharger Bracket Finish: Polished	satin	HO only	-	+\$325
	add "BST" to part #	Supercharger Bracket (Stage II) Finish: Black	satin	Stage II only	-	+\$375
	add "PST" to part #	Supercharger Bracket (Stage II) Finish: Polished	satin	Stage II only	-	+\$475
	add "P1X" to part #	Supercharger Upgrade: P-1X	P-1SC-1	-	add'l 10-15+ hp	+\$250
	add "P1R" to part #	Supercharger Upgrade: P-1R	P-1SC-1	Tuner Kits only	-	+\$600
	add "D1SC" to part #	Supercharger Upgrade: D-1SC	P-1SC-1	Tuner Kits only	-	+\$300
	add "D1X" to part #	Supercharger Upgrade: D-1X	P-1SC-1	Tuner Kits only	-	+\$500
	add "D" or "1" or "A"	Supercharger Upgrade: F-1D, F-1, F-1A	P-1SC-1	Stage II Tuner Kits only	-	+\$900
	add "H" to part #	Gears: Helical gearset for noise reduction	straight-cut	P- or D-series only	-	+\$110
	add "RVR" or "RVB"	Race Blow-off Valve Upgrade (specify open or closed, alum or steel, red or blk)	ProFlow	Stage II only	-	+\$295
	6.1L ONLY	add "MS" to part #	MAP sensor adaptor bag	-	Tuner Kits only	-
	add "FP" to part #	In-Tank Fuel Pump	-	Tuner Kits only	-	+\$550

SPECIFICATIONS

2006-10 DODGE CHARGER HEMI SRT8 (6.1) SPECIFICATIONS

Year	Part Number	OEM hp Rating	HP Gain	Tube Diam	IC Mount	Drive System	Blow-off System	Fuel System Upgrade	Fuel Inj. Supplied	Computer/Ignition Modifications	SC Warranty (in months)	CARB E.O.	Foot Notes
2006-10	1DD314-SCI-6.1	425	160+ hp	3"	V	stk 6-rib	ProFlow	MAP sensor, in-tank pump	39.5 lbs/hr	programmer supplied	12, 36 opt. (\$99)	D-365-7	Y: 1, 3, 6, 8
2006-10	1DD304-SCI-6.1	425	specify	3"	V	stk 6-rib	ProFlow	not supplied	No	not supplied	12	-	Y: 1, 3, 6, 8
2006-10	1DD214-SCI-6.1	425	160+ hp	3"	V	add'l 8-rib	ProFlow	MAP sensor, in-tank pump	39.5 lbs/hr	programmer supplied	12, 36 opt. (\$99)	-	Y: 1, 2, 3, 6, 7, 8
2006-10	1DD204-SCI-6.1	425	specify	3"	V	add'l 8-rib	ProFlow	not supplied	No	not supplied	12	-	Y: 1, 3, 6, 7, 8

2006-10 DODGE CHARGER HEMI R/T (5.7) SPECIFICATIONS

Year	Part Number	OEM hp Rating	HP Gain	Tube Diam	IC Mount	Drive System	Blow-off System	Fuel System Upgrade	Fuel Inj. Supplied	Computer/Ignition Modifications	SC Warranty (in months)	CARB E.O.	Foot Notes
2006-10	1DD314-SCI-5.7	340/370	110+/130+* hp	3"	V	stk 6-rib	ProFlow	MAP sensor	39.5 lbs/hr	programmer supplied	12, 36 opt. (\$99)	D-365-7	Y: 1, 3, 6, 8
2006-10	1DD304-SCI-5.7	340/370	specify	3"	V	stk 6-rib	ProFlow	not supplied	No	not supplied	12	-	Y: 1, 3, 6, 8
2006-08	1DD214-SCI-5.7	340	110+ hp	3"	V	add'l 8-rib	ProFlow	MAP sensor	39.5 lbs/hr	programmer supplied	12, 36 opt. (\$99)	-	Y: 1, 2, 3, 6, 7, 8
2006-08	1DD204-SCI-5.7	340	specify	3"	V	add'l 8-rib	ProFlow	not supplied	No	not supplied	12	-	Y: 1, 3, 6, 7, 8

* 130+ hp with 2009-10 5.7L VCT engines

DODGE/AUTOMOTIVE FOOTNOTES (specific to above applications):

- Y1) Model year must be specified
 Y2) Due to variability among OEM computers, the prevalence of custom modifications, and age/miles/condition of vehicles, dyno tuning may be required
 Y3) Specify engine size (5.7 or 6.1)
 Y5) Purchase of aftermarket balancer required (not included - specify hardened hub):
 5.7 (2006-08) = ATI PP part #918435
 6.1 = ATI PP part #918432
 Y6) 2WD models only; AWD models must use Tuner Kit and may require modifications
 Y7) Special order kit: order form and non-refundable deposit required at time of order—may require additional lead time for processing
 Y8) Race valve requires fabrication on aluminum plenum equipped applications



CALL FOR INFO ON RECENT MODEL YEAR 300 (6.4L)

2012-14 CHRYSLER 300 HEMI SRT8 (6.4) SYSTEMS AND KITS

Year	Part Number	Description	Boost Options	HP Gain	Intercooler	Price/MAP
2012-14	1DK314-SCI	High Output Intercooled System with P-1SC-1	7 psi	200+ hp	3 Core	\$8,598
2012-14	1DK304-SCI	High Output Intercooled Tuner Kit with P-1SC-1	specify	specify	3 Core	\$7,398

2011-23 CHRYSLER 300 HEMI (5.7) SYSTEMS AND KITS

Year	Part Number	Description	Boost Options	HP Gain	Intercooler	Price/MAP
2015-23	1DK414-SCI	High Output Intercooled System with P-1SC-1	7 psi	160+ hp	3 Core	\$8,598
2015-23	1DK404-SCI	High Output Intercooled Tuner Kit with P-1SC-1	specify	specify	3 Core	\$7,398
2011-14	1DK414-SCI	High Output Intercooled System with P-1SC-1	7 psi	160+ hp	3 Core	\$8,598
2011-14	1DK404-SCI	High Output Intercooled Tuner Kit with P-1SC-1	specify	specify	3 Core	\$7,398

2005-10 CHRYSLER 300 / 2005-08 MAGNUM HEMI (6.1) SYSTEMS AND KITS

Year	Part Number	Description	Boost Options	HP Gain	Intercooler	Price/MAP
2005-10 (6.1)	1DE314-SCI-6.1	High Output Intercooled System with P-1SC-1	7 psi	160+ hp	3 Core	\$8,298
2005-10 (6.1)	1DE304-SCI-6.1	High Output Intercooled Tuner Kit with P-1SC-1	specify	specify	3 Core	\$6,998

2005-10 CHRYSLER 300 / 2005-08 MAGNUM HEMI (5.7) SYSTEMS AND KITS

Year	Part Number	Description	Boost Options	HP Gain	Intercooler	Price/MAP
2005-10 (5.7)	1DE314-SCI-5.7	High Output Intercooled System with P-1SC-1	7 psi	110+/130+* hp	3 Core	\$7,998
2005-10 (5.7)	1DE304-SCI-5.7	High Output Intercooled Tuner Kit with P-1SC-1	specify	specify	3 Core	\$6,998

Applications	Part Number Suffix	Description	Upgrade From	Requirements	Notes	Price/MAP
ALL	add "B" to part #	Supercharger Finish: Black, max 9.75" housing	satn	max 9.75" housing	-	+\$295
	add "P" to part #	Supercharger Finish: Polished, max 9.75" housing	satn	max 9.75" housing	-	+\$400
	add "BB" to part #	Supercharger Bracket Finish: Black	satn	-	-	+\$225
	add "PB" to part #	Supercharger Bracket Finish: Polished	satn	-	-	+\$325
	add "P1X" to part #	Supercharger Upgrade: P-1X	P-1SC-1	-	add'l 10-15+ hp	+\$250
	add "P1R" to part #	Supercharger Upgrade: P-1R	P-1SC-1	Tuner Kits only	-	+\$600
	add "D1SC" to part #	Supercharger Upgrade: D-1SC	P-1SC-1	Tuner Kits only	-	+\$300
	add "D1X" to part #	Supercharger Upgrade: D-1X	P-1SC-1	Tuner Kits only	-	+\$500
	add "D" or "-1" or "-A"	Supercharger Upgrade: F-1D, F-1, F-1A	P-1SC-1	Tuner Kits only	-	+\$900
	add "H" to part #	Gears: Helical gearset for noise reduction	straight-cut	P- or D-series only	-	+\$110
	add "Race" to part #	Intercooler Upgrade: Race air-to-air, 1000 HP max	3 core	Tuner Kits only	N/A for 2005-10	+\$435
	add "RVR" or "RVB"	Race Blow-off Valve Upgrade (specify open or closed, alum or steel, red or blk)	ProFlow	-	-	+\$295

SPECIFICATIONS

2012-14 CHRYSLER 300 HEMI SRT8 (6.4) SPECIFICATIONS

Year	Part Number	OEM hp Rating	HP Gain	Tube Diam	Intercooler Mount	Drive System	Blow-off System	Fuel System Upgrade	Fuel Inj. Supplied	Computer/Ignition Modifications	SC Warranty (in months)	CARB E.O.	Foot Notes
2012-14	1DK314-SCI	470	200+ hp	3"	V	stk 6-rib	ProFlow	MAP sensor, in-tank pump	52 lbs/hr	programmer sup.	12, 36 opt. (\$99)	D-365-22	Z: 1, 2, 6
2012-14	1DK304-SCI	470	specify	3"	V	stk 6-rib	ProFlow	not supplied	No	not supplied	12	-	Z: 1, 2, 6

2011-23 CHRYSLER 300 HEMI (5.7) SPECIFICATIONS

Year	Part Number	OEM hp Rating	HP Gain	Tube Diam	Intercooler Mount	Drive System	Blow-off System	Fuel System Upgrade	Fuel Inj. Supplied	Computer/Ignition Modifications	SC Warranty (in months)	CARB E.O.	Foot Notes
2015-23	1DK414-SCI	360	160+ hp	3"	V	stk 6-rib	ProFlow	MAP sensor	39.5 lbs/hr	programmer sup.	12, 36 opt. (\$99)	D-365-22 (15-19)	Z: 1, 2, 3, 4, 6
2015-23	1DK404-SCI	360	specify	3"	V	stk 6-rib	ProFlow	not supplied	No	not supplied	12	-	Z: 1, 2, 3, 4, 6
2011-14	1DK414-SCI	360	160+ hp	3"	V	stk 6-rib	ProFlow	MAP sensor	39.5 lbs/hr	programmer sup.	12, 36 opt. (\$99)	D-365-22 (12-14)	Z: 1, 2, 3, 6
2011-14	1DK404-SCI	360	specify	3"	V	stk 6-rib	ProFlow	not supplied	No	not supplied	12	-	Z: 1, 2, 3, 4, 6

2005-10 CHRYSLER 300 / 2005-08 MAGNUM HEMI (6.1) SPECIFICATIONS

Year	Part Number	OEM hp Rating	HP Gain	Tube Diam	Intercooler Mount	Drive System	Blow-off System	Fuel System Upgrade	Fuel Inj. Supplied	Computer/Ignition Modifications	SC Warranty (in months)	CARB E.O.	Foot Notes
2005-10 (6.1)	1DE314-SCI-6.1	425	160+ hp	3"	V	stk 6-rib	ProFlow	MAP sensor, in-tank pump	39.5 lbs/hr	programmer sup.	12, 36 opt. (\$99)	D-365-7	Z: 1, 2, 3, 5, 6
2005-10 (6.1)	1DE304-SCI-6.1	425	specify	3"	V	stk 6-rib	ProFlow	not supplied	No	not supplied	12	-	Z: 1, 2, 3, 5, 6

2005-10 CHRYSLER 300 / 2005-08 MAGNUM HEMI (5.7) SPECIFICATIONS

Year	Part Number	OEM hp Rating	HP Gain	Tube Diam	Intercooler Mount	Drive System	Blow-off System	Fuel System Upgrade	Fuel Inj. Supplied	Computer/Ignition Modifications	SC Warranty (in months)	CARB E.O.	Foot Notes
2005-10 (5.7)	1DE314-SCI-5.7	340/360	110+/130+* hp	3"	V	stk 6-rib	ProFlow	MAP sensor	39.5 lbs/hr	programmer sup.	12, 36 opt. (\$99)	D-365-7	Z: 1, 2, 3, 5
2005-10 (5.7)	1DE304-SCI-5.7	340/360	specify	3"	V	stk 6-rib	ProFlow	not supplied	No	not supplied	12	-	Z: 1, 2, 3, 5

* 130+ hp with 2009-10 5.7L VCT engines

CHRYSLER AUTOMOTIVE FOOTNOTES (specific to above applications):

- Z1) Model year must be specified
- Z2) Specify engine size (5.7, 6.1, or 6.4)
- Z3) 2WD models only; AWD models must use Tuner Kit and may require modifications
- Z4) 2015+ vehicles may require ECM unlock (call for details)
- Z5) 2006-10 vehicles require removal of adaptive cruise control sensor
- Z6) Race valve requires fabrication on aluminum plenum equipped applications



***NEW* 2024-26 FORD F-150 (5.0 4V) SYSTEMS AND KITS**

Year	Part Number	Description	Boost Options	HP Gain	Intercooler	Price/MAP
2024-26	1EC311-SCI	Stage 1 Intercooled System with P-1X (3/36 Warranty Eligible)	10 psi	65-70%	1300+ hp	\$9,098
2024-26	1EC411-SCI	Stage 2 Intercooled System with P-1X (shared drive)	12 psi	75-80%+	1300+ hp	\$9,398
2024-26	1EC401-SCI	Stage 2 Intercooled Tuner Kit with P-1X (shared drive)	specify	specify	1300+ hp	\$8,298
2024-26	1EC511-SCI	Stage 3 Intercooled System with P-1X (dedicated drive)	12 psi	75-80%+	1600+ hp	\$10,648
2024-26	1EC501-SCI	Stage 3 Intercooled Tuner Kit with P-1X (dedicated drive)	specify	specify	1600+ hp	\$9,548

***NEW* 2024-26 FORD F-150 PRO POWER ONBOARD (5.0 4V) SYSTEMS AND KITS**

Year	Part Number	Description	Boost Options	HP Gain	Intercooler	Price/MAP
2024-26	1EC312-SCI	Stage 1 Intercooled System with P-1X (3/36 Warranty Eligible)	10 psi	65-70%	1300+ hp	\$9,348
2024-26	1EC412-SCI	Stage 2 Intercooled System with P-1X (shared drive)	12 psi	75-80%	1300+ hp	\$9,648
2024-26	1EC402-SCI	Stage 2 Intercooled Tuner Kit with P-1X (shared drive)	specify	specify	1300+ hp	\$8,548

***UPDATED* 2021-23 FORD F-150 (5.0 4V) SYSTEMS AND KITS**

Year	Part Number	Description	Boost Options	HP Gain	Intercooler	Price/MAP
2021-23	1EA311-SCI	Stage 1 Intercooled System with P-1X (shared drive)	10 psi	65-70%	1300+ hp	\$8,998
2021-23	1EA411-SCI	Stage 2 Intercooled System with P-1SC-1 (shared drive)	11-12 psi	75-80%+	1300+ hp	\$9,398
2021-23	1EA401-SCI	Stage 2 Intercooled Tuner Kit with P-1SC-1 (shared drive)	specify	specify	1300+ hp	\$8,298
2021-23	1EA511-SCI	Stage 3 Intercooled System with P-1SC-1 (dedicated drive)	11-12 psi	75-80%+	1600+ hp	\$10,648
2021-23	1EA501-SCI	Stage 3 Intercooled Tuner Kit with P-1SC-1 (dedicated drive)	specify	specify	1600+ hp	\$9,548

***NEW* 2020-26 FORD F-250/350 SUPER DUTY (6.8, 7.3) SYSTEMS AND KITS**

Year	Part Number	Description	Boost Options	HP Gain	Intercooler	Price/MAP
2020-26	1FZ211-SCI	High Output Intercooled System with P-1SC-1	7-8 psi	55-65%+	3 core	\$9,598
2020-26	1FZ201-SCI	High Output Intercooled Tuner Kit with P-1SC-1	specify	specify	3 core	\$8,998

Type	Part Number Suffix	Description	Upgrade From	Requirements	Notes	Price/MAP
FINISH OPTIONS	add "-MB" to part #	Machined Billet Finish for Supercharger & Bracket	satin billet	max 9" housing	only 5.0L	+\$100
	add "-B" to part #	Supercharger Finish: Black, max 9.75" housing	satin	max 9.75" housing	-	+\$295
	add "-P" to part #	Supercharger Finish: Polished, max 9.75" housing	satin	max 9.75" housing	-	+\$400
	add "-BB" to part #	Supercharger Bracket Finish: Black	satin	-	-	+\$225
	add "-PB" to part #	Supercharger Bracket Finish: Polished	satin	-	-	+\$325
	add "-BI" to part #	Intercooler Finish: Black	raw	-	-	+\$195
SUPER-CHARGERS	add "-P1R" to part #	Supercharger Upgrade: P-1R	P-1X	Tuner Kits only	-	+\$300
	add "-D1SC" to part #	Supercharger Upgrade: D-1SC	P-1X	Tuner Kits only	-	+\$50
	add "-D1X" to part #	Supercharger Upgrade: D-1X	P-1X	Tuner Kits only	-	+\$200
	add "-D" or "-1" or "-A"	Supercharger Upgrade: F-1D, F-1, F-1A	P-1X	Tuner Kits only	-	+\$600
	add "-94" or "-C" or "-R"	Supercharger Upgrade: F-1A-94, F-1C or F-1R	P-1X	Tuner Kits only	-	+\$950
	add "-103" to part #	Supercharger Upgrade: F-1R-103	P-1X	Tuner Kits only	-	+\$2,000
	add "-P1X" to part #	Supercharger Upgrade: P-1X	P-1SC-1	-	add'l 10-15+ hp	+\$250
	add "-P1R" to part #	Supercharger Upgrade: P-1R	P-1SC-1	Tuner Kits only	-	+\$600
	add "-D1SC" to part #	Supercharger Upgrade: D-1SC	P-1SC-1	Tuner Kits only	-	+\$300
	add "-D1X" to part #	Supercharger Upgrade: D-1X	P-1SC-1	Tuner Kits only	-	+\$500
KIT UPGRADES	add "-D" or "-1" or "-A"	Supercharger Upgrade: F-1D, F-1, F-1A	P-1SC-1	Tuner Kits only	-	+\$900
	add "-94" to part #	Supercharger Upgrade: F-1A-94	P-1SC-1	Tuner Kits only	-	+\$1,250
	add "-FPT" to part #	Ford Performance calibration and handheld	-	Stage 2, 3 only	-	+\$200
	add "-WTY" to part #	3-year / 36,000-mile powertrain warranty (2024-26 only)	-	2024-26 Stage 1 only	-	call
	add "-H" to part #	Gears: Helical gearset for noise reduction	straight-cut	P- or D-series only	-	+\$110
	add "-BV" to part #	Bullet Blow-off Valve Upgrade (black only)	ProFlow	-	-	+\$125
	add "-RVR" or "RVB"	Race Blow-off Valve Upgrade (specify open or closed, alum or steel, red or blk)	ProFlow	-	-	+\$295
	add "-SII" to part #	Intercooler Upgrade: Stage II air-to-air, 1,600 HP max	1,300 HP	2021-25 5.0L only	-	+\$435
add "-10R" to part #	10-rib drive system upgrade	8-rib	-	only 5.0L	+\$360	
add "-CS" to part #	Coyote Crank Support, satin finish	-	Stage 3 only	only 5.0L	+\$675	
add "-BC" or "-PC" to part #	Black or Polished finish for Crank Support	satin	-	only 5.0L	+\$275	

SPECIFICATIONS

***NEW* 2024-26 FORD F-150 (5.0 4V) SPECIFICATIONS**

Year	Part Number	OEM hp/TQ Rating	HP Gain	Tube Diam	IC Mount	Drive System	Blow-off System	Fuel System Upgrade	Fuel Inj. Supplied	Computer/Ignition Modifications	SC Warranty (in months)	CARB E.O.	Foot Notes
2024-26	1EC311-SCI	400/410	65-70%	3.5"	V	stk 6-rib	ProFlow	not required	not required	programmer supplied	12, 36 opt. (\$99)	-	ED: 1, 2, 4, 5
2024-26	1EC411-SCI	400/410	75-80%+	3.5"	V	stk 6-rib	ProFlow	not required	55 lb/hr	programmer supplied	12, 36 opt. (\$99)	-	ED: 1, 2, 4, 5
2024-26	1EC401-SCI	400/410	75-80%+	3.5"	V	stk 6-rib	ProFlow	not required	55 lb/hr	not supplied	12	-	ED: 1, 2, 4, 5
2024-26	1EC511-SCI	400/410	75-80%+	3.5"	V	add'l 8-rib	ProFlow	not required	55 lb/hr	programmer supplied	12, 36 opt. (\$99)	-	ED: 1, 2, 4, 5, 7, 8
2024-26	1EC501-SCI	400/410	75-80%+	3.5"	V	add'l 8-rib	ProFlow	not required	55 lb/hr	not supplied	12	-	ED: 1, 2, 4, 5, 7, 8

***NEW* 2024-26 FORD F-150 PRO POWER ONBOARD (5.0 4V) SPECIFICATIONS**

Year	Part Number	OEM hp/TQ Rating	HP Gain	Tube Diam	IC Mount	Drive System	Blow-off System	Fuel System Upgrade	Fuel Inj. Supplied	Computer/Ignition Modifications	SC Warranty (in months)	CARB E.O.	Foot Notes
2024-26	1EC312-SCI	400/410	65-70%	3.5"	V	stk 6-rib	ProFlow	not required	not required	programmer supplied	12, 36 opt. (\$99)	-	ED: 1, 2, 3, 4, 5
2024-26	1EC412-SCI	400/410	75-80%	3.5"	V	stk 6-rib	ProFlow	not required	55 lb/hr	programmer supplied	12, 36 opt. (\$99)	-	ED: 1, 2, 3, 4, 5, 6, 7, 8
2024-26	1EC402-SCI	400/410	specify	3.5"	V	stk 6-rib	ProFlow	not required	No	not supplied	12	-	ED: 1, 2, 3, 4, 5

***UPDATED* 2021-23 FORD F-150 (5.0 4V) SPECIFICATIONS**

Year	Part Number	OEM hp/TQ Rating	HP Gain	Tube Diam	IC Mount	Drive System	Blow-off System	Fuel System Upgrade	Fuel Inj. Supplied	Computer/Ignition Modifications	SC Warranty (in months)	CARB E.O.	Foot Notes
2021-23	1EC311-SCI	395/400	65-70%	3.5"	V	stk 6-rib	ProFlow	not required	not required	programmer supplied	12, 36 opt. (\$99)	-	ED: 1, 2, 4, 5
2021-23	1EA411-SCI	395/400	75-80%+	3.5"	V	stk 6-rib	ProFlow	not required	55 lb/hr	programmer supplied	12, 36 opt. (\$99)	-	ED: 1, 2, 3, 4, 5
2021-23	1EA401-SCI	395/400	specify	3.5"	V	stk 6-rib	ProFlow	not required	No	not supplied	12	-	ED: 1, 2, 4, 5
2021-23	1EA511-SCI	395/400	75-80%+	3.5"	V	add'l 8-rib	ProFlow	not required	55 lb/hr	programmer supplied	12, 36 opt. (\$99)	-	ED: 1, 2, 3, 4, 5, 7, 8
2021-23	1EA501-SCI	395/400	specify	3.5"	V	add'l 8-rib	ProFlow	not required	No	not supplied	12	-	ED: 1, 2, 4, 5, 7, 8

***NEW* 2020-26 FORD F-250/350 SUPER DUTY (6.8, 7.3) SPECIFICATIONS**

Year	Part Number	OEM hp/TQ Rating	HP Gain	Tube Diam	IC Mount	Drive System	Blow-off System	Fuel System Upgrade	Fuel Inj. Supplied	Computer/Ignition Modifications	SC Warranty (in months)	CARB E.O.	Foot Notes
2020-26	1FZ211-SCI	430/475	55-65%+	3"	V	stk 6-rib	Bullet	not required	50 lb/hr	programmer supplied	12, 36 opt. (\$99)	-	ED: 1, 3, 4, 6, 9
2020-26	1FZ201-SCI	430/475	specify	3"	V	stk 6-rib	Bullet	not required	No	not supplied	12	-	ED: 1, 6, 9

FORD TRUCK/SUV FOOTNOTES (specific to above applications):

- ED1) Model year must be specified
- ED2) Specify 2WD or 4WD
- ED3) Due to variability among OEM computers, the prevalence of custom modifications, and age/miles/condition of vehicles, dyno tuning may be required
- ED4) For Flex Fuel vehicles, gasoline-only tune provided, not E85
- ED5) 2015+ models require aerodynamic grill shutter removal and/or trimming
- ED6) Works with dual battery; dual alternator requires removing one alternator; 2023+ requires dealer recalibration
- ED7) Specify stock or aftermarket balancer (8-rib and 10-rib both use ATI Balancer P/N 918055 or Innovator's West P/N 817)
- ED8) Crank Support requires aftermarket balancer
- ED9) Specify engine displacement - 6.8L or 7.3L



2018-20 FORD F-150 (5.0 4V) SYSTEMS AND KITS

Year	Part Number	Description	Boost Options	HP Gain	Intercooler	Price/MAP
2018-20	1FY411-SCI	High Output Intercooled System with P-1SC-1	11-12 psi	75-80%+	3 core	\$8,398
2018-20	1FY401-SCI	High Output Intercooled Tuner Kit with P-1SC-1	specify	specify	3 core	\$7,998
2018-20	1FY511-SCI	Stage II Intercooled System with P-1SC-1	11-12 psi	75-80%+	Race	\$8,798
2018-20	1FY501-SCI	Stage II Intercooled Tuner Kit with P-1SC-1	specify	specify	Race	\$8,398

2015-17 FORD F-150 (5.0 4V) SYSTEMS AND KITS

Year	Part Number	Description	Boost Options	HP Gain	Intercooler	Price/MAP
2015-17	1FY311-SCI	High Output Intercooled System with P-1SC-1 (50-state emissions legal)	8-9 psi	60-70%	3 core	\$8,598
2015-17	1FY301-SCI	High Output Intercooled Tuner Kit with P-1SC-1	specify	specify	3 core	\$7,998
2015-17	1FY312-SCI	Stage II Intercooled System with P-1SC-1	11-12 psi	85-90%+	Race	\$8,998
2015-17	1FY302-SCI	Stage II Intercooled Tuner Kit with P-1SC-1	specify	specify	Race	\$8,398

2011-14 FORD F-150 (5.0, 6.2 4V) SYSTEMS AND KITS

Year	Part Number	Description	Boost Options	HP Gain	Intercooler	Price/MAP
2011-14 (5.0)	1FV211-SCI-5.0	High Output Intercooled System with P-1SC-1	6-7 psi	45-55%	3 core	\$7,798
2011-14 (5.0)	1FV201-SCI-5.0	High Output Intercooled Tuner Kit with P-1SC-1	specify	specify	3 core	\$7,398
2011-14 (5.0)	1FV311-SCI-5.0	Stage II Intercooled System with P-1SC-1	8-9 psi	60-70%	Race	\$8,448
2011-14 (5.0)	1FV301-SCI-5.0	Stage II Intercooled Tuner Kit with P-1SC-1	specify	specify	Race	\$8,048
2011-14 (6.2)	1FS311-SCI-6.2	High Output Intercooled System with D-1SC (6.2)	7-8 psi	50%+	3 core	\$8,248
2011-14 (6.2)	1FS301-SCI-6.2	High Output Intercooled Tuner Kit with D-1SC (6.2)	specify	specify	3 core	\$7,298
2011-14 (6.2)	1FS211-SCI-6.2	Stage II Intercooled System with P-1SC-1 (6.2)	7-8 psi	50%+	3 core	\$8,898
2011-14 (6.2)	1FS201-SCI-6.2	Stage II Intercooled Tuner Kit with P-1SC-1 (6.2)	specify	specify	3 core	\$7,948

Type	Part Number Suffix	Description	Upgrade	Requirements	Notes	Price/MAP
FINISH OPTIONS	add "B" to part #	Supercharger Finish: Black, max 9.75" housing	satn	max 9.75" housing	-	+\$295
	add "P" to part #	Supercharger Finish: Polished, max 9.75" housing	satn	max 9.75" housing	-	+\$400
	add "BB" to part #	Supercharger Bracket Finish: Black	satn	-	-	+\$225
	add "PB" to part #	Supercharger Bracket Finish: Polished	satn	-	-	+\$325
SUPERCHARGERS	add "P1X" to part #	Supercharger Upgrade: P-1X	P-1SC-1	-	add'l 10-15+ hp	+\$250
	add "P1R" to part #	Supercharger Upgrade: P-1R	P-1SC-1	Tuner Kits only	-	+\$600
	add "D1SC" to part #	Supercharger Upgrade: D-1SC	P-1SC-1	Tuner Kits only	-	+\$300
	add "D1X" to part #	Supercharger Upgrade: D-1X	P-1SC-1	Tuner Kits only	-	+\$500
	add "D" or "-1" or "-A"	Supercharger Upgrade: F-1D, F-1, F-1A	P-1SC-1	Tuner Kits only	-	+\$900
	add "D" or "-1" or "-A"	Supercharger Upgrade: F-1D, F-1, F-1A	D-1SC	Stage II Tuner Kits only	-	+\$575
add "94" to part #	Supercharger Upgrade: F-1A-94	P-1SC-1	Tuner Kits only	-	+\$1,250	
KIT UPGRADES	add "H" to part #	Gears: Helical gearset for noise reduction	straight-cut	P- or D-series only	-	+\$110
	add "BV" to part #	Bullet Blow-off Valve Upgrade (black only)	ProFlow	-	-	+\$125
	add "RVR" or "RVB"	Race Blow-off Valve Upgrade (specify open or closed, alum or steel, red or blk)	ProFlow	-	-	+\$295
	add "SII" to part #	Intercooler Upgrade: Stage II air-to-air, 1,000 HP max	3-core	-	3" tubing	+\$435
	add "BI" to part #	Intercooler Finish: Black	raw	-	-	+\$195
	add "CS" to part #	Coyote Crank Support, satin finish	-	Stage II only	-	+\$675
	add "BC" or "PC" to part #	Black or Polished finish for Crank Support	satn	-	-	+\$275
add "FA" to part #	Air Inlet Upgrade: Forward facing	rear facing	2011-14 5.0L only	-	+\$130	
i-1 ONLY	SEE PAGE 88 FOR i-1 OPTIONS					

FOR COYOTE & GODZILLA ENGINE SWAP KITS, SEE PAGE 24
2011-14 FORD F-150 (5.0, 6.2 4V) i-1 PROGRAMMABLE RATIO SYSTEMS

Year	Part Number	Description	Boost Options	HP Gain	Intercooler	Price/MAP
2011-14 (5.0)	1FV215-SCI	High Output Intercooled System with i-1 (5.0)	8-9 psi	60-70%	Race	\$12,498
2011-14 (6.2)	1FS215-SCI	High Output Intercooled System with i-1 (6.2)	8 psi	55%+	3 core	\$12,598

SPECIFICATIONS

2018-20 FORD F-150 (5.0 4V) SPECIFICATIONS

Year	Part Number	OEM hp/TQ Rating	HP Gain	Tube Diam	IC Mount	Drive System	Blow-off System	Fuel System Upgrade	Fuel Inj. Supplied	Computer/Ignition Modifications	SC Warranty (in months)	CARB E.O.	Foot Notes
2018-20	1FY411-SCI	395/400	75-80%+	3"	V	add'l 8-rib	ProFlow	supplied	not required	programmer supplied	12, 36 opt. (\$99)	-	EE: 1, 2, 3, 4, 7
2018-20	1FY401-SCI	395/400	specify	3"	V	add'l 8-rib	ProFlow	not required	No	not supplied	12	-	EE: 1, 2, 4, 7
2018-20	1FY511-SCI	395/400	75-80%+	3"	V	add'l 8-rib	ProFlow	supplied	not required	programmer supplied	12, 36 opt. (\$99)	-	EE: 1, 2, 3, 4, 7, 10, 11
2018-20	1FY501-SCI	395/400	specify	3"	V	add'l 8-rib	ProFlow	not required	No	not supplied	12	-	EE: 1, 2, 4, 7, 10, 11

2015-17 FORD F-150 (5.0 4V) SPECIFICATIONS

Year	Part Number	OEM hp/TQ Rating	HP Gain	Tube Diam	IC Mount	Drive System	Blow-off System	Fuel System Upgrade	Fuel Inj. Supplied	Computer/Ignition Modifications	SC Warranty (in months)	CARB E.O.	Foot Notes
2015-17	1FY311-SCI	385/387	60-70%	3"	V	add'l 8-rib	ProFlow	not required	52 lb/hr	programmer supplied	12, 36 opt. (\$99)	D-365-32	EE: 1, 2, 4, 7
2015-17	1FY301-SCI	385/387	specify	3"	V	add'l 8-rib	ProFlow	not required	No	not supplied	12	-	EE: 1, 2, 4, 7
2015-17	1FY312-SCI	385/387	85-90%+	3"	V	add'l 8-rib	ProFlow	supplied	55 lb/hr	programmer supplied	12, 36 opt. (\$99)	-	EE: 1, 2, 3, 4, 7, 10, 11
2015-17	1FY302-SCI	385/387	specify	3"	V	add'l 8-rib	ProFlow	not required	No	not supplied	12	-	EE: 1, 2, 4, 7, 10, 11

2011-14 FORD F-150 (5.0, 6.2 4V) SPECIFICATIONS

Year	Part Number	OEM hp/TQ Rating	HP Gain	Tube Diam	IC Mount	Drive System	Blow-off System	Fuel System Upgrade	Fuel Inj. Supplied	Computer/Ignition Modifications	SC Warranty (in months)	CARB E.O.	Foot Notes
2011-14 (5.0)	1FV211-SCI	360/380	45-55%	3"	V	add'l 8-rib	ProFlow	not required	not required	programmer supplied	12, 36 opt. (\$99)	D-365-32	EE: 1, 2, 4, 6
2011-14 (5.0)	1FV201-SCI	360/380	specify	3"	V	add'l 8-rib	ProFlow	not required	No	not supplied	12	-	EE: 1, 2, 4, 6
2011-14 (5.0)	1FV311-SCI	360/380	60-70%	3"	V	add'l 8-rib	ProFlow	not required	52 lb/hr	programmer supplied	12, 36 opt. (\$99)	D-365-32	EE: 1, 2, 4, 10, 11
2011-14 (5.0)	1FV301-SCI	360/380	specify	3"	V	add'l 8-rib	ProFlow	not required	No	not supplied	12	-	EE: 1, 2, 4, 10, 11
2011-14 (6.2)	1FS311-SCI-6.2	411/434	50%+	3"	V	stk 6-rib	ProFlow	not required	63 lb/hr	programmer supplied	12, 36 opt. (\$99)	-	EE: 1, 2, 3, 4, 6
2011-14 (6.2)	1FS301-SCI-6.2	411/434	specify	3"	V	stk 6-rib	ProFlow	not required	No	not supplied	12	-	EE: 1, 2, 6
2011-14 (6.2)	1FS211-SCI-6.2	411/434	50%+	3"	V	add'l 8-rib	ProFlow	not required	63 lb/hr	programmer supplied	12, 36 opt. (\$99)	D-365-32	EE: 1, 2, 4, 10, 11
2011-14 (6.2)	1FS201-SCI-6.2	411/434	specify	3"	V	add'l 8-rib	ProFlow	not required	No	not supplied	12	-	EE: 1, 2, 10, 11

2011-14 FORD F-150 (5.0, 6.2 4V) i-1 PROGRAMMABLE RATIO SPECIFICATIONS

Year	Part Number	OEM hp/TQ Rating	HP Gain	Tube Diam	IC Mount	Drive System	Blow-off System	Fuel System Upgrade	Fuel Inj. Supplied	Computer/Ignition Modifications	SC Warranty (in months)	CARB E.O.	Foot Notes
2011-14 (5.0)	1FV215-SCI	360/380	60-70%	3"	V	add'l 8-rib	ProFlow	not required	52 lb/hr	programmer supplied	12, 36 opt. (\$599)	-	EE: 1, 2, 3, 4, 7, 8
2011-14 (6.2)	1FS215-SCI	411/434	55%+	3"	V	add'l 8-rib	ProFlow	not required	63 lb/hr	programmer supplied	12, 36 opt. (\$599)	-	EE: 1, 2, 3, 4, 7, 8

FORD TRUCK/SUV FOOTNOTES (specific to above applications):

- EE1) Model year must be specified
- EE2) Specify 2WD or 4WD
- EE3) Due to variability among OEM computers, the prevalence of custom modifications, and age/miles/condition of vehicles, dyno tuning may be required
- EE4) For Flex Fuel vehicles, gasoline-only tune provided, not E85
- EE5) ECM code required on hand-held programmer applications
- EE7) Two-part shipment, additional shipping charges may apply
- EE8) Special order kit: order form and non-refundable deposit required at time of order; may require additional lead time for processing
- EE9) 2015+ models require aerodynamic grill shutter removal and/or trimming
- EE10) Specify stock or aftermarket balancer (utilizes 8-rib ATI Balancer P/N 918047 (2011-14), P/N 918055 (2015+), or Innovator's West P/N 817)
- EE11) Crank Support requires aftermarket balancer



2010-14 FORD F-150 SVT RAPTOR (5.4, 6.2 3V) SYSTEMS AND KITS

Year	Part Number	Description	Boost Options	HP Gain	Intercooler	Price/MAP
2010-14 (6.2)	1FS311-SCI-6.2	High Output Intercooled System with D-1SC	7-8 psi	50%+	3 core	\$8,248
2010-14 (6.2)	1FS301-SCI-6.2	High Output Intercooled Tuner Kit with D-1SC	specify	specify	3 core	\$7,248
2010-14 (6.2)	1FS211-SCI-6.2	Stage II Intercooled System with P-1SC-1 (dedicated 8-rib drive)	7-8 psi	50%+	Race	\$8,898
2010-14 (6.2)	1FS201-SCI-6.2	Stage II Intercooled Tuner Kit with P-1SC-1 (dedicated 8-rib drive)	specify	specify	Race	\$7,798
2010 (5.4)	1FS211-SCI-5.4	High Output Intercooled System with P-1SC-1	8-9 psi	60%+	3 core	\$8,398
2010 (5.4)	1FS201-SCI-5.4	High Output Intercooled Tuner Kit with P-1SC-1	specify	specify	3 core	\$7,398

2004-10 FORD F-150 AND 2007-10 EXPEDITION (5.4 3V) SYSTEMS AND KITS

Year	Part Number	Description	Boost Options	HP Gain	Intercooler	Price/MAP
2009-10	1FN211-SCI	High Output Intercooled System with P-1SC-1 (F-150)	8-9 psi	60-65%	2 core	\$7,698
2009-10	1FN201-SCI	High Output Intercooled Tuner Kit with P-1SC-1 (F-150)	specify	specify	2 core	\$6,898
2004-08	1FN211-SCI	High Output Intercooled System with P-1SC-1 (F-150)	8-9 psi	60-65%	2 core	\$7,498
2004-08	1FN201-SCI	High Output Intercooled Tuner Kit with P-1SC-1 (F-150)	specify	specify	2 core	\$6,898
2007-08	1FN211-SCI	High Output Intercooled System with P-1SC-1 (Expedition)	8-9 psi	60-65%	2 core	\$7,698
2007-10	1FN201-SCI	High Output Intercooled Tuner Kit with P-1SC-1 (Expedition)	specify	specify	2 core	\$6,898

1997-03 FORD F-150 AND 1997-02 EXPEDITION (5.4, 4.6 2V) SYSTEMS AND KITS

Year	Part Number	Description	Boost Options	HP Gain	Intercooler	Price/MAP
1997-03 (5.4)	1FG211-SCI	High Output Intercooled System with P-1SC (F150/Expedition*)	8-9 psi	60-65%	2 or 3 core, see footnotes	\$6,998
1997-03 (5.4)	1FG201-SCI	High Output Intercooled Tuner Kit with P-1SC (F150/Expedition*)	specify	specify	2 or 3 core, see footnotes	\$6,698
1997-03 (4.6)	1FH211-SCI	High Output Intercooled System with P-1SC (F150/Expedition*)	8-9 psi	60-65%	2 or 3 core, see footnotes	\$6,998
1997-03 (4.6)	1FH201-SCI	High Output Intercooled Tuner Kit with P-1SC (F150/Expedition*)	specify	specify	2 or 3 core, see footnotes	\$6,698

NEW 1988-1996 FORD F-150 / BRONCO (5.0, 5.8) SYSTEMS AND KITS

Year	Part Number	Description	Boost Options	HP Gain	Intercooler	Price/MAP
1988-96	1ED400-SCI	High Output Tuner Kit with D-1SC	specify	specify	-	call

COYOTE ENGINE SWAP 92-96 F-150/LIGHTNING/BRONCO (5.0 4V) KITS

Year	Part Number	Description	Boost Options	HP Gain	Intercooler	Price/MAP
specify	1FA700-P1SC1-I	High Output Intercooled Tuner Kit with P-1SC-1	specify	specify	Stage II	\$7,198

Type	Part Number Suffix	Description	Upgrade From	Requirements	Notes	Price/MAP
FINISH OPTIONS	add "-B" to part #	Supercharger Finish: Black, max 9.75" housing	satin	max 9.75" housing	-	+\$295
	add "-P" to part #	Supercharger Finish: Polished, max 9.75" housing	satin	max 9.75" housing	-	+\$400
	add "-BB" to part #	Supercharger Bracket Finish: Black	satin	-	-	+\$225
	add "-PB" to part #	Supercharger Bracket Finish: Polished	satin	-	-	+\$325
SUPER-CHARGERS	add "-P1X" to part #	Supercharger Upgrade: P-1X	P-1SC-1	-	add'l 10-15+ hp	+\$250
	add "-P1R" to part #	Supercharger Upgrade: P-1R	P-1SC-1	Tuner Kits only	-	+\$600
	add "-D1SC" to part #	Supercharger Upgrade: D-1SC	P-1SC-1	Tuner Kits only	-	+\$300
	add "-D1X" to part #	Supercharger Upgrade: D-1X	P-1SC-1	Stage II Tuner Kit Only	-	+\$500
	add "-D1SC" to part #	Supercharger Upgrade: D-1SC	P-1SC	1997-2003 only	-	+\$525
KIT UPGRADES	add "-A" to part #	Supercharger Upgrade: F-1A	D-1SC	Tuner Kits only	-	+\$575
	add "-Race" to part #	Intercooler Upgrade: Race air-to-air, 1050 HP max	3-core	Raptor only	-	+\$435
	add "-3C" to part #	Intercooler Upgrade: 3-core air-to-air, 825 HP max	2-core	-	-	+\$435
	add "-I" to part #	Add Intercooler	-	-	-	call
	add "-RVR" or "RVB" to part #	Race Blow-off Valve Upgrade (specify open or closed, alum or steel, red or blk)	ProFlow	-	-	+\$295
i-1 ONLY	add "-H" to part #	Gears: Helical gearset for noise reduction	straight-cut	P- or D-series only	-	+\$110

* Excludes 2003 Expedition
FOR COYOTE & GODZILLA ENGINE SWAP KITS. SEE PAGE 24

SPECIFICATIONS

2010-14 FORD F-150 SVT RAPTOR (6.2, 5.4 3V) SPECIFICATIONS

Year	Part Number	OEM hp/TQ Rating	HP Gain	Tube Diam	IC Mount	Drive System	Blow-off System	Fuel System Upgrade	Fuel Inj. Supplied	Computer/Ignition Modifications	SC Warranty (in months)	CARB E.O.	Foot Notes
2010-14 (6.2)	1FS311-SCI-6.2	411/434	50%+	3"	V	stk 6-rib	ProFlow	not required	63 lb/hr	programmer sup.	12, 36 opt. (\$99)	-	FF: 1, 2, 3, 6
2010-14 (6.2)	1FS301-SCI-6.2	411/434	specify	3"	V	stk 6-rib	ProFlow	not required	12	not supplied	12	-	FF: 1, 2, 6
2010-14 (6.2)	1FS211-SCI-6.2	411/434	50%+	3"	V	add'l 8-rib	ProFlow	not required	63 lb/hr	programmer sup.	12, 36 opt. (\$99)	D-365-8	FF: 1, 6
2010-14 (6.2)	1FS201-SCI-6.2	411/434	specify	3"	V	add'l 8-rib	ProFlow	not required	No	not supplied	12	-	FF: 1, 6
2010 (5.4)	1FS211-SCI-5.4	320/390	60%	3"	V	stk 6-rib	ProFlow	not required	39.5 lb/hr	programmer sup.	12, 36 opt. (\$99)	D-365-8	FF: 1, 2, 3, 6
2010 (5.4)	1FS201-SCI-5.4	320/390	specify	3"	V	stk 6-rib	ProFlow	not required	No	not supplied	12	-	FF: 1, 2, 6

2004-10 FORD F-150 & 2007-10 EXPEDITION (5.4 3V) SPECIFICATIONS

Year	Part Number	OEM hp/TQ Rating	HP Gain	Tube Diam	IC Mount	Drive System	Blow-off System	Fuel System Upgrade	Fuel Inj. Supplied	Computer/Ignition Modifications	SC Warranty (in months)	CARB E.O.	Foot Notes
2009-10 (5.4)	1FN211-SCI	310/365	60-65%	3"	V	stk 6-rib	ProFlow	not required	not req.	programmer sup.	12, 36 opt. (\$99)	D-365-8	FF: 1, 2, 6, 7
2009-10 (5.4)	1FN201-SCI	310/365	specify	3"	V	stk 6-rib	ProFlow	not required	No	not supplied	12	-	FF: 1, 2
2004-08 (5.4)	1FN211-SCI	300/365	60-65%	3"	V	stk 6-rib	ProFlow	not required	39.5 lb/hr	programmer sup.	12, 36 opt. (\$99)	D-365-8	FF: 1, 2, 7
2004-08 (5.4)	1FN201-SCI	300/365	specify	3"	V	stk 6-rib	ProFlow	not required	No	not supplied	12	-	FF: 1, 2
2007-08 (5.4)	1FN211-SCI	300/365	60-65%	3"	V	stk 6-rib	ProFlow	not required	39.5 lb/hr	programmer sup.	12, 36 opt. (\$99)	D-365-8	FF: 1, 2, 7
2007-10 (5.4)	1FN201-SCI	300/365	specify	3"	V	stk 6-rib	ProFlow	not required	No	not supplied	12	-	FF: 1, 2

1997-03 FORD F-150 & 1997-02 EXPEDITION (5.4, 4.6 2V) SPECIFICATIONS

Year	Part Number	OEM hp/TQ Rating	HP Gain	Tube Diam	IC Mount	Drive System	Blow-off System	Fuel System Upgrade	Fuel Inj. Supplied	Computer/Ignition Modifications	SC Warranty (in months)	CARB E.O.	Foot Notes
1997-03 (5.4)	1FG211-SCI	260/345	60-65%	3"	V	add'l 6-rib	ProFlow	ProPump, FMU	not req.	not required	12, 36 opt. (\$99)	D-365-2/8	FF: 1, 2, 3, 4, 9
1997-03 (5.4)	1FG201-SCI	260/345	specify	3"	V	add'l 6-rib	ProFlow	not supplied	not req.	not required	12	-	FF: 1, 2, 3, 4, 9
1997-03 (4.6)	1FH211-SCI	210/290	60-65%	3"	V	add'l 6-rib	ProFlow	ProPump, FMU	not req.	not required	12, 36 opt. (\$99)	D-365-8 (02-03)	FF: 1, 2, 3, 4, 9
1997-03 (4.6)	1FH201-SCI	210/290	specify	3"	V	add'l 6-rib	ProFlow	not supplied	not req.	not required	12	-	FF: 1, 2, 3, 4, 9

NEW 1988-1996 FORD F-150 / BRONCO (5.0, 5.8) SYSTEMS AND KITS

Year	Part Number	OEM hp/TQ Rating	HP Gain	Tube Diam	IC Mount	Drive System	Blow-off System	Fuel System Upgrade	Fuel Inj. Supplied	Computer/Ignition Modifications	SC Warranty (in months)	CARB E.O.	Foot Notes
1988-96	1ED400-SCI	411/434	55%+	3"	V	stk 6-rib	Bullet	not supplied	No	not supplied	12	-	FF: 1, 2, 3, 5

COYOTE ENGINE SWAP 92-96 F-150/LIGHTNING/BRONCO (5.0 4V) SPECIFICATIONS

Year	Part Number	OEM hp/TQ Rating	HP Gain	Tube Diam	tercool Mount	Drive System	Blow-off Valve	Fuel System Upgrade	Fuel Inj. Supplied	Computer/Ignition Modifications	SC Warranty (in months)	CARB E.O.	Foot Notes
specify	1FA700-P1SC1-I	N/A	specify	3"	V	add'l 8-rib	ProFlow	not supplied	No	not supplied	12	-	FF: 1, 8, 9, 11

FORD TRUCK/SUV FOOTNOTES (specific to above applications):

- FF1) Model year must be specified
- FF2) Specify 2WD or 4WD, Truck or SUV
- FF3) Fits Light Duty F-250 applications with minor modifications
- FF4) 1997-98 Ford F-150/Expedition systems/kits include 2 core intercooler, 1999-03 include 3 core intercooler
- FF5) Due to variability among OEM computers, the prevalence of custom modifications, and age/miles/condition of vehicles, dyno tuning may be required
- FF6) For Flex Fuel vehicles, gasoline-only tune provided, not E85
- FF7) ECM code required on hand-held programmer applications
- FF8) Specify factory or aftermarket balancer
- FF9) Reverse mount Coyote swap kits require car GT timing cover
- FF10) Two-part shipment, additional shipping charges may apply
- FF11) Requires 2015+ Mustang accessories and utilizes 2015+ Mustang intercooler and tubing



***NEW* 2019-26 GM TRUCK 1500 (5.3, 6.2) SYSTEMS AND KITS**

Year	Part Number	Description	Boost Options	HP Gain	Intercooler	Price/MAP
2019-26 (5.3)	1KA213-SCI	High Output Intercooled Systems with P-1SC-1	8 psi	45-50%*	3 core	\$8,998
2019-26 (5.3)	1KA202-SCI	High Output Intercooled Tuner Kit with P-1SC-1	specify	specify	3 core	\$7,798
2019-26 (6.2)	1KA212-SCI	High Output Intercooled Systems with P-1SC-1	8 psi	45-50%*	3 core	\$8,998
2019-26 (6.2)	1KA202-SCI	High Output Intercooled Tuner Kit with P-1SC-1	specify	specify	3 core	\$7,798
2019-26 (5.3,6.2)	1KA312-SCI	Stage II Intercooled System w/ P-1SC-1	8 psi	45-50%*	Stage II	\$9,598
2019-26 (5.3,6.2)	1KA302-SCI	Stage II Intercooled Tuner Kit w/ P-1SC-1	specify	specify	Stage II	\$8,398

***NEW* 2021-26 GM SUVs - ESCALADE, TAHOE, SUBURBAN, YUKON, DENALI (5.3, 6.2) SYSTEMS AND KITS**

Year	Part Number	Description	Boost Options	HP Gain	Intercooler	Price/MAP
2021-26 (5.3)	1KB213-SCI	High Output Intercooled Systems with P-1SC-1	8 psi	45-50%*	3 core	\$8,998
2021-26 (5.3)	1KB202-SCI	High Output Intercooled Tuner Kit with P-1SC-1	specify	specify	3 core	\$7,798
2021-26 (6.2)	1KB212-SCI	High Output Intercooled Systems with P-1SC-1	8 psi	45-50%*	3 core	\$8,998
2021-26 (6.2)	1KB202-SCI	High Output Intercooled Tuner Kit with P-1SC-1	specify	specify	3 core	\$7,998
2021-26 (5.3,6.2)	1KB312-SCI	Stage II Intercooled System w/ P-1SC-1	8 psi	45-50%*	Stage II	\$9,598
2021-26 (5.3,6.2)	1KB302-SCI	Stage II Intercooled Tuner Kit w/ P-1SC-1	specify	specify	Stage II	\$8,398

***NEW* 2020-26 GM TRUCK 2500 (6.6) SYSTEMS AND KITS**

Year	Part Number	Description	Boost Options	HP Gain	Intercooler	Price/MAP
2020-26	1KA314-SCI	High Output Intercooled Systems with P-1SC-1	6 psi	50-55%	3 core	\$8,598
2020-26	1KA304-SCI	High Output Intercooled Tuner Kit with P-1SC-1	specify	specify	3 core	\$7,498
2020-26	1KA414-SCI	Stage II Intercooled Systems with P-1SC-1	6 psi	50-55%	Stage II	\$9,198
2020-26	1KA404-SCI	Stage II Intercooled Tuner Kit with P-1SC-1	specify	specify	Stage II	\$8,098

Applications	Part Number Suffix	Description	Upgrade	Requirements	Notes	Price/MAP
ALL	add "-B" to part #	Supercharger Finish: Black, max 9.75" housing	satn	max 9.75" housing	-	+\$295
	add "-P" to part #	Supercharger Finish: Polished, max 9.75" housing	satn	max 9.75" housing	-	+\$400
	add "-BB" to part #	Supercharger Bracket Finish: Black	satn	-	-	+\$225
	add "-PB" to part #	Supercharger Bracket Finish: Polished	satn	-	-	+\$325
	add "-H" to part #	Gears: Helical gearset for noise reduction	straight-cut	P- or D-series only	-	+\$110
	add "-P1X" to part #	Supercharger Upgrade: P-1X	P-1SC-1	-	add'l 10-15+ hp	+\$250
	add "-P1R" to part #	Supercharger Upgrade: P-1R	P-1SC-1	Tuner Kits only	-	+\$600
	add "-D1SC" to part #	Supercharger Upgrade: D-1SC	P-1SC-1	Tuner Kits only	-	+\$300
	add "-D1X" to part #	Supercharger Upgrade: D-1X	P-1SC-1	Tuner Kits only	-	+\$500
	5.3L & 6.2L ONLY	add "-SII" to part #	Intercooler Upgrade: Stage II air-to-air, 950 HP max	HO	-	-
add "-AIR" to part #		Air Inlet Upgrade: Stage II Package	HO std inlet	-	-	+\$110
add "-D" or "-1" or "-A"		Supercharger Upgrade: F-1D, F-1, F-1A	P-1SC-1	Tuner Kits only	-	+\$900
add "-94" to part #		Supercharger Upgrade: F-1A-94	P-1SC-1	Stage II Tuner Kits only	-	+\$1,250
6.6L ONLY	add "-BV" to part #	Bullet Blow-off Valve Upgrade (black only)	ProFlow	-	-	+\$125
	add "-RVR" or "RVB"	Race Blow-off Valve Upgrade (specify open or closed, alum or steel, red or blk)	ProFlow	Stage II Tuner Kits only	-	+\$295

* This is the largest power gain that can be produced with the stock fuel system. If others are claiming more, that is not factual.

SPECIFICATIONS

***NEW* 2019-26 GM TRUCK 1500 (5.3, 6.2) SPECIFICATIONS**

Year	Part Number	OE hp/TQ Rating	HP Gain	Tube Diam	IC Mount	Drive System	Blow-off System	Fuel System Upgrade	Fuel Inj. Supplied	Computer/Ignition Modifications	SC Warranty (in months)	CARB E.O.	Foot Notes
2019-26 (5.3)	1KA213-SCI	355/383	45-50%*	3"	V	add'l 8-rib	Bullet	not required	not required	programmer sup.	12, 36 opt. (\$99)	D-365-37 (19-23)	BA: 1, 2, 4, 6, 8, 9
2019-26 (5.3)	1KA202-SCI	355/383	specify	3"	V	add'l 8-rib	Bullet	not required	No	not supplied	12	-	BA: 1, 2, 5
2019-26 (6.2)	1KA212-SCI	420/460	45-50%*	3"	V	add'l 8-rib	Bullet	not required	not required	programmer sup.	12, 36 opt. (\$99)	D-365-37 (19-23)	BA: 1, 2, 4, 6, 8, 9
2019-26 (6.2)	1KA202-SCI	420/460	specify	3"	V	add'l 8-rib	Bullet	not required	No	not supplied	12	-	BA: 1, 2, 5
2019-26 (5.3,6.2)	1KA312-SCI	355,420/383,460	45-50%*	3"	V	add'l 8-rib	Bullet	not required	not required	programmer sup.	12, 36 opt. (\$99)	-	BA: 1, 2, 4, 6, 7, 8, 9
2019-26 (5.3,6.2)	1KA302-SCI	355,420/383,460	specify	3"	V	add'l 8-rib	Bullet	not supplied	No	not supplied	12	-	BA: 1, 2, 7

***NEW* 2021-26 GM SUVs - ESCALADE, TAHOE, SUBURBAN, YUKON, DENALI (5.3, 6.2) SPECIFICATIONS**

Year	Part Number	OE hp/TQ Rating	HP Gain	Tube Diam	IC Mount	Drive System	Blow-off System	Fuel System Upgrade	Fuel Inj. Supplied	Computer/Ignition Modifications	SC Warranty (in months)	CARB E.O.	Foot Notes
2021-26 (5.3)	1KB213-SCI	355/383	45-50%*	3"	V	add'l 8-rib	Bullet	not required	not required	programmer sup.	12, 36 opt. (\$99)	-	BA: 1, 2, 3, 8, 9
2021-26 (5.3)	1KB202-SCI	355/383	specify	3"	V	add'l 8-rib	Bullet	not supplied	No	not supplied	12	-	BA: 1, 2, 3, 5
2021-26 (6.2)	1KB212-SCI	420/460	45-50%*	3"	V	add'l 8-rib	Bullet	not required	not required	programmer sup.	12, 36 opt. (\$99)	-	BA: 1, 2, 3, 8, 9
2021-26 (6.2)	1KB202-SCI	420/460	specify	3"	V	add'l 8-rib	Bullet	not supplied	No	not supplied	12	-	BA: 1, 2, 3, 5
2021-26 (5.3,6.2)	1KB312-SCI	355,420/383,460	45-50%*	3"	V	add'l 8-rib	Bullet	not required	not required	programmer sup.	12, 36 opt. (\$99)	-	BA: 1, 2, 3, 6, 7, 8, 9
2021-26 (5.3,6.2)	1KB302-SCI	355,420/383,460	specify	3"	V	add'l 8-rib	Bullet	not supplied	No	not supplied	12	-	BA: 1, 2, 3, 7

***NEW* 2020-26 GM TRUCK 2500/3500 (6.6) SPECIFICATIONS**

Year	Part Number	OE hp/TQ Rating	HP Gain	Tube Diam	IC Mount	Drive System	Blow-off System	Fuel System Upgrade	Fuel Inj. Supplied	Computer/Ignition Modifications	SC Warranty (in months)	CARB E.O.	Foot Notes
2020-26	1KA314-SCI	401/464	50-55%	3"	V	add'l 6-rib	ProFlow	not required	not required	programmer sup.	12, 36 opt. (\$99)	-	BA: 1, 2, 4, 6, 8, 9
2020-26	1KA304-SCI	401/464	specify	3"	V	add'l 6-rib	ProFlow	not supplied	No	not supplied	12	-	BA: 1, 2, 5
2020-26	1KA414-SCI	401/464	50-55%	3"	V	add'l 8-rib	ProFlow	not required	not required	programmer sup.	12, 36 opt. (\$99)	-	BA: 1, 2, 4, 6, 8, 9
2020-26	1KA404-SCI	401/464	specify	3"	V	add'l 8-rib	ProFlow	not supplied	No	not supplied	12	-	BA: 1, 2, 5

* This is the largest power gain that can be produced with the stock fuel system. If others are claiming more, that is not factual.

CHEVROLET TRUCK/SUV FOOTNOTES (specific to above applications):

- BA1) Model year must be specified
- BA2) Specify 2WD or 4WD, Truck or SUV, and GMC or Chevrolet
- BA3) Specify engine size
- BA4) For Flex Fuel vehicles, gasoline-only tune provided, not E85
- BA5) Due to the wide variance of chassis and options available, modifications may be required
- BA6) Due to variability among OEM computers, the prevalence of custom modifications, and age/miles/condition of vehicles, dyno tuning may be required
- BA7) Stage II intercooler requires trimming
- BA8) PCM removal and shipment required for all
- BA9) Specify VIN #



2014-18 GM TRUCK 1500 (5.3, 6.2) SYSTEMS AND KITS

Year	Part Number	Description	Boost Options	HP Gain	Intercooler	Price/MAP
2014-18 (5.3)	1GV213-SCI	High Output Intercooled System with P-1SC-1	8 psi	45%+	3 core	\$7,998
2014-18 (5.3)	1GV202-SCI	High Output Intercooled Tuner Kit with P-1SC-1	specify	specify	3 core	\$7,548
2014-18 (6.2)	1GV212-SCI	High Output Intercooled System with P-1SC-1	8 psi	45%+	3 core	\$7,998
2014-18 (6.2)	1GV202-SCI	High Output Intercooled Tuner Kit with P-1SC-1	specify	specify	3 core	\$7,548
2014-18 (5.3/6.2)	1GV312-SCI	Stage II Intercooled System w/ P-1SC-1 (dedicated drive)	8 psi	45%+	3 core	\$8,598
2014-18 (5.3/6.2)	1GV302-SCI	Stage II Intercooled Tuner Kit w/ P-1SC-1 (dedicated drive)	specify	specify	3 core	\$8,248

2015-20 GM SUV - ESCALADE, TAHOE, SUBURBAN, YUKON, DENALI (5.3, 6.2) SYSTEMS AND KITS

Year	Part Number	Description	Boost Options	HP Gain	Intercooler	Price/MAP
2015-20 (5.3)	1GV213-SCI	High Output Intercooled System with P-1SC-1	8 psi	45%+	3 core	\$7,998
2015-20 (5.3)	1GV202-SCI	High Output Intercooled Tuner Kit with P-1SC-1	specify	specify	3 core	\$7,548
2015-20 (6.2)	1GV212-SCI	High Output Intercooled System with P-1SC-1	8 psi	45%+	3 core	\$7,998
2015-20 (6.2)	1GV202-SCI	High Output Intercooled Tuner Kit with P-1SC-1	specify	specify	3 core	\$7,548

2015-19 GM TRUCK 2500 (6.0) SYSTEMS AND KITS

Year	Part Number	Description	Boost Options	HP Gain	Intercooler	Price/MAP
2015-19	1GV314-SCI	High Output Intercooled Systems with P-1SC-1	7-8 psi	45%+	3 core	\$7,898
2015-19	1GV304-SCI	High Output Intercooled Tuner Kit with P-1SC-1	specify	specify	3 core	\$6,848

Applications	Part Number Suffix	Description	Upgrade From	Requirements	Notes	Price/MAP	
ALL	add "-B" to part #	Supercharger Finish: Black, max 9.75" housing	satn	max 9.75" housing	-	+\$295	
	add "-P" to part #	Supercharger Finish: Polished, max 9.75" housing	satn	max 9.75" housing	-	+\$400	
	add "-B" to part #	Supercharger Finish: Black, 10.5" housing	satn	10.5" housing	-	+\$395	
	add "-P" to part #	Supercharger Finish: Polished, 10.5" housing	satn	10.5" housing	-	+\$500	
	add "-BB" to part #	Supercharger Bracket Finish: Black	satn	-	-	+\$225	
	add "-PB" to part #	Supercharger Bracket Finish: Polished	satn	-	-	+\$325	
	add "-D1SC" to part #	Supercharger Upgrade: D-1SC	P-1SC-1	Tuner Kits only	-	+\$300	
	add "-H" to part #	Gears: Helical gearset for noise reduction	straight-cut	P- or D-series only	-	+\$110	
	add "-FA" to part #	Air Inlet Upgrade: Forward facing	rear facing	High Output only	-	+\$130	
	add "-RVR" or "-RVB"	Race Blow-off Valve Upgrade (specify open or closed, alum or steel, red or blk)	ProFlow	Stage II Tuner Kits only	-	+\$295	
	add "-V" to part #	Intercooler Upgrade: Vertical Intercooler Option, 950 HP max	3-core	-	-	+\$215	
	add "-Race" to part #	Intercooler Upgrade: Race air-to-air, 1600 HP max	3-core	Stage II Tuner Kits only	-	+\$750	
	5.3L, 6.2L ONLY	add "-P1X" to part #	Supercharger Upgrade: P-1X	P-1SC-1	-	add'l 10-15+ hp	+\$250
		add "-P1R" to part #	Supercharger Upgrade: P-1R	P-1SC-1	Tuner Kits only	-	+\$600
add "-D1SC" to part #		Supercharger Upgrade: D-1SC	P-1SC-1	Tuner Kits only	-	+\$300	
add "-D1X" to part #		Supercharger Upgrade: D-1X	P-1SC-1	Tuner Kits only	-	+\$500	
add "-D" or "-1" or "-A"		Supercharger Upgrade: F-1D, F-1, F-1A	P-1SC-1	Tuner Kits only	-	+\$900	
add "-94" or "-C" or "-R"		Supercharger Upgrade: F-1A-94, F-1C or F-1R	P-1SC-1	Tuner Kits only	-	+\$1,250	
add "-103" to part #		Supercharger Upgrade: F-1R-103	P-1SC-1	Tuner Kits only	-	+\$2,300	
add "-F1X" to part #		Supercharger Upgrade: F-1X	P-1SC-1	Tuner Kits only	-	+\$2,500	
add "-10R" to part #		10-rib drive system upgrade	8-rib	-	-	+\$360	

SPECIFICATIONS

2014-18 GM TRUCK 1500 (5.3, 6.2) SPECIFICATIONS

Year	Part Number	OE hp/TQ Rating	HP Gain	Tube Diam	IC Mount	Drive System	Blow-off System	Fuel System Upgrade	Fuel Inj. Supplied	Computer/Ignition Modifications	SC Warranty (in months)	CARB E.O.	Foot Notes
2014-18 (5.3)	1GV213-SCI	355/383	45%+	3"	H / V	stk 6-rib	ProFlow	not required	not required	programmer sup.	12, 36 opt. (\$99)	D-365-28	BB: 1, 2, 3, 7, 9
2014-18 (5.3)	1GV202-SCI	355/383	specify	3"	H / V	stk 6-rib	ProFlow	not supplied	No	not supplied	12	-	BB: 1, 2, 3, 7
2014-18 (6.2)	1GV212-SCI	420/460	45%+	3"	H / V	stk 6-rib	ProFlow	not required	not required	programmer sup.	12, 36 opt. (\$99)	D-365-28	BB: 1, 2, 3, 7, 9
2014-18 (6.2)	1GV202-SCI	420/460	specify	3"	H / V	stk 6-rib	ProFlow	not supplied	No	not supplied	12	-	BB: 1, 2, 3, 7
2014-18 (5.3/6.2)	1GV312-SCI	see above	45%+	3"	H / V	add'l 8-rib	ProFlow	not required	not required	programmer sup.	12, 36 opt. (\$99)	D-365-28	BB: 1, 2, 3, 7, 8, 9
2014-18 (5.3/6.2)	1GV302-SCI	see above	specify	3"	H / V	add'l 8-rib	ProFlow	not supplied	No	not supplied	12	-	BB: 1, 2, 3, 7, 8

2015-20 GM SUV - ESCALADE, TAHOE, SUBURBAN, YUKON, DENALI (5.3, 6.2) SPECIFICATIONS

Year	Part Number	OE hp/TQ Rating	HP Gain	Tube Diam	IC Mount	Drive System	Blow-off System	Fuel System Upgrade	Fuel Inj. Supplied	Computer/Ignition Modifications	SC Warranty (in months)	CARB E.O.	Foot Notes
2015-20 (5.3)	1GV213-SCI	355/383	45%+	3"	H	stk 6-rib	ProFlow	not required	not required	programmer sup.	12, 36 opt. (\$99)	D-365-28	BB: 1, 2, 3, 6, 9
2015-20 (5.3)	1GV202-SCI	355/383	specify	3"	H	stk 6-rib	ProFlow	not supplied	No	not supplied	12	-	BB: 1, 2, 3
2015-20 (6.2)	1GV212-SCI	420/460	45%+	3"	H	stk 6-rib	ProFlow	not required	not required	programmer sup.	12, 36 opt. (\$99)	D-365-28	BB: 1, 2, 3, 6, 9
2015-20 (6.2)	1GV202-SCI	420/460	specify	3"	H	stk 6-rib	ProFlow	not supplied	No	not supplied	12	-	BB: 1, 2, 3

2015-19 GM TRUCK 2500 (6.0) SPECIFICATIONS

Year	Part Number	OE hp/TQ Rating	HP Gain	Tube Diam	IC Mount	Drive System	Blow-off System	Fuel System Upgrade	Fuel Inj. Supplied	Computer/Ignition Modifications	SC Warranty (in months)	CARB E.O.	Foot Notes
2015-19	1GV314-SCI	360/380	45%+	3"	V	stk 6-rib	ProFlow	not required	56 lb/hr	programmer sup.	12, 36 opt. (\$99)	-	BB: 1, 2, 4, 6, 9
2015-19	1GV304-SCI	360/380	specify	3"	V	stk 6-rib	ProFlow	not supplied	No	not supplied	12	-	BB: 1, 2, 5

CHEVY TRUCK/SUV FOOTNOTES (specific to above applications):

- BB1) Model year must be specified
- BB2) Specify 2WD or 4WD, Truck or SUV, and GMC or Chevrolet
- BB3) Specify engine size
- BB4) For Flex Fuel vehicles, gasoline-only tune provided, not E85
- BB5) Due to the wide variance of chassis and options available, modifications may be required
- BB6) Due to variability among OEM computers, the prevalence of custom modifications, and age/miles/condition of vehicles, dyno tuning may be required
- BB7) 2017-18 trucks require vertical intercooler
- BB8) Specify stock or aftermarket balancer (IW #760 or ATI #918645 + #916358, specify hardened hub)
- BB9) Due to potential OEM transmissions issues, no TCM changes are included



2007-13 GM TRUCK 1500 / 2007-14 SUV (4.8, 5.3) SYSTEMS AND KITS (LATE 2007-2013)

Year	Part Number	Description	Boost Options	HP Gain	Intercooler	Price/MAP
2007-13 (4.8)	1GR212-SCI	High Output Intercooled System with P-1SC-1	8-9 psi	50-55%	2 core	\$7,478
2007-13 (5.3)	1GR212-SCI	High Output Intercooled System with P-1SC-1	8-9 psi	50-55%	2 core	\$7,478
2007-13 (4.8 / 5.3)	1GR202-SCI	High Output Intercooled Tuner Kit with P-1SC-1	specify	specify	2 core	\$6,578
2007-13 (4.8)	1GR312-SCI	Stage II Intercooled System with P-1SC-1 (dedicated drive)	8-9 psi	50-55%	2 core	\$8,248
2007-13 (5.3)	1GR312-SCI	Stage II Intercooled System with P-1SC-1 (dedicated drive)	8-9 psi	50-55%	2 core	\$8,248
2007-13 (4.8 / 5.3)	1GR302-SCI	Stage II Intercooled Tuner Kit with P-1SC-1 (dedicated drive)	specify	specify	2 core	\$7,398

2007-13 GM TRUCK 1500 / 2007-14 SUV / 2007-11 2500 (6.0, 6.2) SYSTEMS AND KITS

Year	Part Number	Description	Boost Options	HP Gain	Intercooler	Price/MAP
2007-09 (6.0)	1GR212-SCI	High Output Intercooled System with P-1SC-1	7-8 psi	50%+	3 core	\$7,898
2007-09 (6.0)	1GR202-SCI	High Output Intercooled Tuner Kit with P-1SC-1	specify	specify	3 core	\$7,898
2007-13 (6.2)	1GR213-SCI	High Output Intercooled System with P-1SC-1	7-8 psi	50%+	3 core	\$7,898
2007-13 (6.2)	1GR202-SCI	High Output Intercooled Tuner Kit with P-1SC-1	specify	specify	3 core	\$7,898
2007-13 (6.0 / 6.2)	1GR312-SCI	Stage II Intercooled System w/ P-1SC-1 (dedicated drive)	7-8 psi	50%+	3 core	\$8,598
2007-13 (6.0 / 6.2)	1GR302-SCI	Stage II Intercooled Tuner Kit w/ P-1SC-1 (dedicated drive)	specify	specify	3 core	\$7,498

Applications	Part Number Suffix	Description	Upgrade From	Requirements	Notes	Price/MAP
FINISH OPTIONS	add "B" to part #	Supercharger Finish: Black, max 9.75" housing	satn	max 9.75" housing	-	+\$295
	add "P" to part #	Supercharger Finish: Polished, max 9.75" housing	satn	max 9.75" housing	-	+\$400
	add "B" to part #	Supercharger Finish: Black, 10.5" housing	satn	10.5" housing	-	+\$395
	add "P" to part #	Supercharger Finish: Polished, 10.5" housing	satn	10.5" housing	-	+\$500
	add "B" to part #	Supercharger Finish: Black, 12" housing	satn	12" housing	-	+\$650
	add "P" to part #	Supercharger Finish: Polished, 12" housing	satn	12" housing	-	+\$750
	add "BB" to part #	Supercharger Bracket Finish: Black	satn	-	-	+\$225
add "PB" to part #	Supercharger Bracket Finish: Polished	satn	-	-	+\$325	
SUPER-CHARGERS	add "P1X" to part #	Supercharger Upgrade: P-1X	P-1SC-1	-	add'l 10-15+ hp	+\$250
	add "P1R" to part #	Supercharger Upgrade: P-1R	P-1SC-1	Tuner Kits only	-	+\$600
	add "D1SC" to part #	Supercharger Upgrade: D-1SC	P-1SC-1	Tuner Kits only	-	+\$300
	add "D1X" to part #	Supercharger Upgrade: D-1X	P-1SC-1	Tuner Kits only	-	+\$500
	add "D" or "1" or "A"	Supercharger Upgrade: F-1D, F-1, F-1A	P-1SC-1	Tuner Kits only	-	+\$900
	add "94" or "C" or "R"	Supercharger Upgrade: F-1A-94, F-1C or F-1R	P-1SC-1	Stage II Tuner Kits only	-	+\$1,250
	add "103" to part #	Supercharger Upgrade: F-1R-103	P-1SC-1	Stage II Tuner Kits only	-	+\$2,300
add "F1X" to part #	Supercharger Upgrade: F-1X	P-1SC-1	Stage II Tuner Kits only	-	+\$2,500	
KIT UPGRADES	add "VI" to part #	Intercooler Upgrade: Vertical Intercooler Option, 950 HP max	3-core	-	may require trimming	+\$215
	add "3C" to part #	Intercooler Upgrade: 3-core air-to-air, 825 HP max	2-core	-	3" tubing	+\$435
	add "H" to part #	Gears: Helical gearset for noise reduction	straight-cut	P- or D-series only	-	+\$110
	add "10R" to part #	10-rib drive system upgrade	8-rib	Tuner Kits only	-	+\$360
	add "RVR" or "RVB"	Race Blow-off Valve Upgrade (specify open or closed, alum or steel, red or blk)	ProFlow	specify	-	+\$295
	add "FA" to part #	Air Inlet Upgrade: Forward facing	rear facing	Stage II only	-	+\$130
i-1 ONLY	SEE PAGE 88 FOR I-1 OPTIONS	Crank Pin Kit	-	-	included with Stage II	+\$109

2007-13 GM TRUCK/SUV 1500/2500 (4.8, 5.3, 6.0, 6.2) i-1 PROGRAMMABLE RATIO SYSTEMS

Year	Part Number	Description	Boost Options	HP Gain	Intercooler	Price/MAP
2007-13 (4.8)	1GR215-SCI	High Output Intercooled System with i-1	8-9 psi	55-60%+	3 core	\$13,498
2007-13 (5.3)	1GR215-SCI	High Output Intercooled System with i-1	8-9 psi	55-60%+	3 core	\$13,498
2007-13 (6.0)	1GR215-SCI	High Output Intercooled System with i-1	7-8 psi	50-55%+	3 core	\$13,498
2007-13 (6.2)	1GR215-SCI	High Output Intercooled System with i-1	7-8 psi	50-55%+	3 core	\$13,498

SPECIFICATIONS

2007-13 GM TRUCK 1500 / 2007-14 SUV (4.8, 5.3) (LATE 2007-2013) SPECIFICATIONS

Year	Part Number	OE hp/TQ Rating	HP Gain	Tube Diam	IC Mount	Drive System	Blow-off System	Fuel System Upgrade	Fuel Inj. Supplied	Computer/Ignition Modifications	SC Warranty (in months)	CARB E.O.	Foot Notes
2007-13 (4.8)	1GR212-SCI	295/305	50-55%	3"	H	stk 6-rib	ProFlow	not required	52 lb/hr	programmer sup.	12, 36 opt. (\$99)	D-365-10	CC: 1, 2, 3, 5, 7, 9
2007-13 (5.3)	1GR212-SCI	315/338	50-55%	3"	H	stk 6-rib	ProFlow	not required	52 lb/hr	programmer sup.	12, 36 opt. (\$99)	D-365-10	CC: 1, 2, 3, 4, 5, 7, 9
2007-13 (4.8/5.3)	1GR202-SCI	-	specify	3"	H	stk 6-rib	ProFlow	not supplied	No	not supplied	12	-	CC: 1, 2, 3, 5, 7, 9
2007-13 (4.8)	1GR312-SCI	295/305	50-55%	3"	H	add'l 8-rib	ProFlow	not required	52 lb/hr	programmer sup.	12, 36 opt. (\$99)	-	CC: 1, 2, 3, 5, 6, 7, 10
2007-13 (5.3)	1GR312-SCI	315/338	50-55%	3"	H	add'l 8-rib	ProFlow	not required	52 lb/hr	programmer sup.	12, 36 opt. (\$99)	-	CC: 1, 2, 3, 4, 5, 6, 7, 10
2007-13 (4.8/5.3)	1GR302-SCI	-	specify	3"	H	add'l 8-rib	ProFlow	not supplied	No	not supplied	12	-	CC: 1, 2, 3, 5, 7, 10, 12

2007-13 GM TRUCK 1500 / 2007-14 SUV / 2007-11 2500 (6.0, 6.2) SPECIFICATIONS

Year	Part Number	OE hp/TQ Rating	HP Gain	Tube Diam	IC Mount	Drive System	Blow-off System	Fuel System Upgrade	Fuel Inj. Supplied	Computer/Ignition Modifications	SC Warranty (in months)	CARB E.O.	Foot Notes
2007-09 (6.0)	1GR212-SCI	367/375	50%+	3"	H	stk 6-rib	ProFlow	pump volt. booster	52 lb/hr	programmer sup.	12, 36 opt. (\$99)	D-365-10	CC: 1, 2, 3, 4, 5, 7, 8, 9
2007-09 (6.0)	1GR202-SCI	367/375	specify	3"	H	stk 6-rib	ProFlow	not supplied	No	not supplied	12	-	CC: 1, 2, 3, 5, 7, 8, 9
2007-13 (6.2)	1GR213-SCI	380/417	50%+	3"	H	stk 6-rib	ProFlow	pump volt. booster	65 lb/hr	programmer sup.	12, 36 opt. (\$99)	D-365-10	CC: 1, 2, 3, 4, 5, 7, 9
2007-13 (6.2)	1GR202-SCI	380/417	specify	3"	H	stk 6-rib	ProFlow	not supplied	No	not supplied	12	-	CC: 1, 2, 3, 5, 7, 9
2007-13 (6.0 / 6.2)	1GR312-SCI	-	50%+	3"	H	add'l 8-rib	ProFlow	pump volt. booster	52/65 lb/hr	programmer sup.	12, 36 opt. (\$99)	-	CC: 1, 2, 3, 4, 5, 6, 7, 10
2007-13 (6.0 / 6.2)	1GR302-SCI	-	specify	3"	H	add'l 8-rib	ProFlow	not supplied	No	not supplied	12	-	CC: 1, 2, 3, 5, 7, 10, 12

2007-13 GM TRUCK/SUV 1500/2500 (4.8, 5.3, 6.0, 6.2) i-1 PROGRAMMABLE RATIO SPECIFICATIONS

Year	Part Number	OE hp/TQ Rating	HP Gain	Tube Diam	IC Mount	Drive System	Blow-off System	Fuel System Upgrade	Fuel Inj. Supplied	Computer/Ignition Modifications	SC Warranty (in months)	CARB E.O.	Foot Notes
2007-13 (4.8)	1GR215-SCI	295/305	55-60%	3"	H	add'l 8-rib	ProFlow	not required	52 lb/hr	programmer sup.	12, 36 opt. (\$559)	-	CC 1, 2, 3, 5, 6, 9, 11
2007-13 (5.3)	1GR215-SCI	315/338	55-60%	3"	H	add'l 8-rib	ProFlow	not required	52 lb/hr	programmer sup.	12, 36 opt. (\$559)	-	CC 1, 2, 3, 5, 6, 9, 11
2007-13 (6.0)	1GR215-SCI	360/380	50-55%+	3"	H	add'l 8-rib	ProFlow	pump volt. booster	52 lb/hr	programmer sup.	12, 36 opt. (\$559)	-	CC: 1, 2, 3, 4, 5, 6, 8, 9, 11
2007-13 (6.2)	1GR215-SCI	380/417	50-55%+	3"	H	add'l 8-rib	ProFlow	pump volt. booster	65 lb/hr	programmer sup.	12, 36 opt. (\$559)	-	CC: 1, 2, 3, 5, 6, 9, 11

CHEVY TRUCK/SUV FOOTNOTES (specific to above applications):

- CC1) Model year must be specified
- CC2) Specify 2WD or 4WD, Truck or SUV
- CC3) Specify engine size
- CC4) For Flex Fuel vehicles, gasoline-only tune provided, not E85
- CC5) Due to the wide variance of chassis and options available, modifications may be required
- CC6) Due to variability among OEM computers, the prevalence of custom modifications, and age/miles/condition of vehicles, dyno tuning may be required
- CC7) 2007 Classic use 1G1213-SCI (HO Intercooled System) or 1G1203-SCI (HO Intercooled Tuner Kit)
- CC8) HD models with Hydroboost may require modifications to power steering reservoir
- CC9) Pinning the balancer to the crank is recommended; Pin kit for stock balancer not supplied
- CC10) Specify stock or optional ATI Balancer #918635 (not included - specify hardened hub)
- CC11) Special order kit: order form and non-refundable deposit required at time of order—may require additional lead time for processing
- CC12) 10-rib belt upgrade requires ATI balancer #918635, not provided

1999-07 GM 1500 CLASSIC TRUCK/SUV (4.8, 5.3, 6.0) SYSTEMS AND KITS

Year	Part Number	Description	Boost Options	HP Gain	Intercooler	Price/MAP
2003-07 (4.8/5.3)	1GI213-SCI	High Output Intercooled System with P-1SC (4.8 / 5.3)	8-9 psi	60-65%	2 core	\$7,498
2003-07 (6.0)	1GI213-SCI	High Output Intercooled System with P-1SC (6.0)	7-8 psi	55-60%	2 core	\$7,498
2003-07	1GI203-SCI	High Output Intercooled Tuner Kit with P-1SC (4.8 / 5.3 / 6.0)	specify	specify	2 core	\$6,748
1999-03 (4.8/5.3)	1GI212-SCI	High Output Intercooled System with P-1SC (4.8 / 5.3)	8-9 psi	60-65%	2 core	\$7,198
1999-03 (6.0)	1GI212-SCI	High Output Intercooled System with P-1SC (6.0)	7-8 psi	55-60%	2 core	\$7,198
1999-03	1GI202-SCI	High Output Intercooled Tuner Kit with P-1SC (4.8 / 5.3 / 6.0)	specify	specify	2 core	\$6,748
1999-07 (4.8/5.3)	1GI512-SCI	Stage II Intercooled System with P-1SC-1 (4.8 / 5.3) (dedicated drive)	8-9 psi	60-65%	3 core	\$8,198
1999-07 (6.0)	1GI512-SCI	Stage II Intercooled System with P-1SC-1 (6.0) (dedicated drive)	7-8 psi	55-60%	3 core	\$8,198
1999-07	1GI502-SCI	Stage II Intercooled Tuner Kit with P-1SC-1 (4.8 / 5.3 / 6.0) (dedicated drive)	specify	specify	3 core	\$7,748

1999-07 GM 2500 CLASSIC TRUCK (6.0) KITS

Year	Part Number	Description	Boost Options	HP Gain	Intercooler	Price/MAP
1999-07	1GI304-SCI	High Output Intercooled Tuner Kit with P-1SC-1	specify	specify	3 core	\$6,998
2004-07	1GI404-SCI	Stage II Intercooled Tuner Kit with P-1SC-1	specify	specify	3 core	\$7,748

LS UNIVERSAL TRUCK SWAP KITS (1999-2013 TRUCK ACCESSORIES)

Year	Part Number	Description	Boost Options	HP Gain	Intercooler	Price/MAP
specify	1LS700-SCI	High Output Tuner Kit with P-1SC-1	specify	specify	-	\$4,698
specify	1LS700-SCI-I	High Output Tuner Kit with Intercooler and P-1SC-1	specify	specify	2 core	\$5,698

Type	Part Number Suffix	Description	Upgrade From	Requirements	Notes	Price/MAP
FINISH OPTIONS	add "-B" to part #	Supercharger Finish: Black, max 9.75" housing	satn	max 9.75" housing	-	+\$295
	add "-P" to part #	Supercharger Finish: Polished, max 9.75" housing	satn	max 9.75" housing	-	+\$400
	add "-B" to part #	Supercharger Finish: Black, 10.5" housing	satn	10.5" housing	-	+\$395
	add "-B" to part #	Supercharger Finish: Black, 10.5" housing	satn	10.5" housing	-	+\$395
	add "-BB" to part #	Supercharger Bracket Finish: Black	satn	-	-	+\$225
	add "-PB" to part #	Supercharger Bracket Finish: Polished	satn	-	-	+\$325
SUPER-CHARGERS	add "-P1X" to part #	Supercharger Upgrade: P-1X	P-1SC	-	-	+\$500
	add "-P1X" to part #	Supercharger Upgrade: P-1X	P-1SC-1	-	add'l 10-15+ hp	+\$250
	add "-P1R" to part #	Supercharger Upgrade: P-1R	P-1SC	-	-	+\$800
	add "-P1R" to part #	Supercharger Upgrade: P-1R	P-1SC-1	Tuner Kits only	-	+\$600
	add "-D1SC" to part #	Supercharger Upgrade: D-1SC	P-1SC	Tuner Kits only	-	+\$525
	add "-D1SC" to part #	Supercharger Upgrade: D-1SC	P-1SC-1	Stage II Tuner Kits only	-	+\$300
	add "-D1X" to part #	Supercharger Upgrade: D-1X	P-1SC	-	-	+\$700
	add "-D1X" to part #	Supercharger Upgrade: D-1X	P-1SC-1	Tuner Kits only	-	+\$500
	add "-D" or "-1" or "-A"	Supercharger Upgrade: F-1D, F-1, F-1A	P-1SC-1	Tuner Kits only	-	+\$900
	add "-D" or "-1" or "-A"	Supercharger Upgrade: F-1D, F-1, F-1A	P-1SC	Stage II Tuner Kits only	-	+\$1,100
	add "-94" to part #	Supercharger Upgrade: F-1A-94	P-1SC-1	Stage II Tuner Kits only	-	+\$1,250
add "-F1X" to part #	Supercharger Upgrade: F-1X	P-1SC-1	Stage II Tuner Kits only	-	+\$2,500	
KIT UPGRADES	add "-3C" to part #	Intercooler Upgrade: 3-core air-to-air, 825 HP max	2-core	-	3" tubing	+\$435
	add "-V" to part #	Intercooler Upgrade: Vertical Intercooler Option	2-core	2004-07 2500 only	3" tubing	+\$435
	add "-H" to part #	Gears: Helical gears for noise reduction	straight-cut	P- or D-series only	-	+\$110
	add "-10R" to part #	10-rib drive system upgrade	8-rib	Stage II Tuner Kits only	-	+\$360
	add "-RV" or "RVB"	Race Blow-off Valve Upgrade (specify open or closed, alum or steel, red or blk)	ProFlow	Tuner Kits only	-	+\$295
	3GKMM-004	Crank Pin Kit	-	-	included in Stage II Kits	+\$109

SPECIFICATIONS

1999-07 GM 1500 CLASSIC TRUCK/SUV (4.8, 5.3, 6.0) SPECIFICATIONS

Year	Part Number	OEM hp/TQ Rating	HP Gain	Tube Diam	IC Mount	Drive System	Blow-off System	Fuel System Upgrade	Fuel Inj. Supplied	Computer/Ignition Modifications	SC Warranty (in months)	CARB E.O.	Foot Notes
2003-07 (4.8/5.3)	1GI213-SCI	285/325	60-65%	3"	H	stk 6-rib	ProFlow	not req'd	49 lb/hr	programmer sup.	12, 36 opt. (\$99)	-	DA: 1, 2, 3, 4, 5, 7, 8, 9
2003-07 (6.0)	1GI213-SCI	320/360	55-60%	3"	H	stk 6-rib	ProFlow	not req'd	49 lb/hr	programmer sup.	12, 36 opt. (\$99)	-	DA: 1, 2, 4, 5, 7, 8, 9
2003-07	1GI203-SCI	-	specify	3"	H	stk 6-rib	ProFlow	not supplied	not supp'd	not supplied	12	-	DA: 1, 2, 4, 5, 7, 9
1999-03 (4.8/5.3)	1GI212-SCI	285/325	60-65%	3"	H	stk 6-rib	ProFlow	ProPump, FMU	not req'd	not required	12, 36 opt. (\$99)	D-365-10	DA: 1, 2, 3, 4, 5, 7, 9
1999-03 (6.0)	1GI212-SCI	320/360	55-60%	3"	H	stk 6-rib	ProFlow	ProPump, FMU	not req'd	not required	12, 36 opt. (\$99)	D-365-10	DA: 1, 2, 3, 4, 5, 7, 9
1999-03	1GI202-SCI	-	specify	3"	H	stk 6-rib	ProFlow	not supplied	not supp'd	not supplied	12	-	DA: 1, 2, 4, 5, 7, 9
1999-07 (4.8/5.3)	1GI512-SCI	285/325	60-65%	3"	V	add'l 8-rib	ProFlow	not req'd	49 lb/hr	programmer sup.	12, 36 opt. (\$99)	-	DA: 1, 2, 3, 4, 5, 6, 7, 8, 10
1999-07 (6.0)	1GI512-SCI	30/360	55-60%	3"	V	add'l 8-rib	ProFlow	not req'd	49 lb/hr	programmer sup.	12, 36 opt. (\$99)	-	DA: 1, 2, 4, 5, 6, 7, 8, 10
1999-07	1GI502-SCI	-	specify	3"	V	add'l 8-rib	ProFlow	not supplied	not supp'd	not supplied	12	-	DA: 1, 2, 4, 6, 5, 7, 10, 12

1999-07 GM 2500 CLASSIC TRUCK (6.0) SPECIFICATIONS

Year	Part Number	OEM hp/TQ Rating	HP Gain	Tube Diam	IC Mount	Drive System	Blow-off System	Fuel System Upgrade	Fuel Inj. Supplied	Computer/Ignition Modifications	SC Warranty (in months)	CARB E.O.	Foot Notes
1999-07	1GI304-SCI	-	specify	3"	H/V	stk 6-rib	ProFlow	not supplied	not supp'd	not supplied	12	-	DA: 1, 2, 4, 5, 7, 9, 11
1999-07	1GI404-SCI	-	specify	3"	H/V	add'l 8-rib	ProFlow	not supplied	not supp'd	not supplied	12	-	DA: 1, 2, 4, 5, 6, 7, 10, 11

LS UNIVERSAL TRUCK SWAP SPECIFICATIONS

Year	Part Number	Stock HP	HP Gain	Tube Diam	IC Mount	Drive System	Blow-off Valve	Fuel System Upgrade	Fuel Inj. Supplied	Computer/Ignition Modifications	SC Warranty (in months)	Tubing Supplied	Foot Notes
specify	1LS700-SCI	N/A	specify	-	-	shared 6-rib	ProFlow	not supplied	not supp'd	not supplied	12	-	DA: 7, 9
specify	1LS700-SCI-I	N/A	specify	3"	-	shared 6-rib	ProFlow	not supplied	not supp'd	not supplied	12	yes	DA: 7, 9, 13

CHEVY TRUCK/SUV FOOTNOTES (specific to above applications):

- DA1) Model year must be specified
- DA2) Specify 2WD or 4WD, Truck or SUV
- DA3) Specify engine size
- DA4) Modifications and custom tuning required for HD/2500 Series applications (Tuner Kits only)
- DA5) Specify if hydroboost option
- DA6) Specify stock or aftermarket balancer (utilizes ATI Balancer P/N 918635)
- DA7) Due to the wide variance of chassis and options available, modifications may be required
- DA8) Due to variability among OEM computers, the prevalence of custom modifications, and age/miles/condition of vehicles, dyno tuning may be required
- DA9) Pinning the balancer to the crank is recommended; Pin kit for stock balancer not supplied
- DA10) Electric fan conversion required (sold separately by others)
- DA11) HD models with Hydroboost may require modifications to power steering reservoir
- DA12) 10-rib belt upgrade requires ATI balancer #918635, not provided
- DA13) Includes universal tubing kit

1996-00 GM TRUCK/SUV (5.7, 7.4) SYSTEMS

Year	Part Number	Description	Boost Options	HP Gain	Intercooler	Price/MAP
1996-00 (5.7)	1GH212-SCI	High Output Intercooled System with P-1SC (5.7)	8-9 psi	60-65%	2 core	\$6,998
1996-00 (5.7)	1GH202-SCI	High Output Intercooled Tuner Kit with P-1SC (5.7)	specify	specify	2 core	\$6,748
1996-00 (7.4)	1GG202-SCI	High Output Intercooled Tuner Kit with P-1SC (7.4)	specify	specify	2 core	\$6,798

1988-95 GM TBI TRUCK/SUV (5.7, 7.4) SYSTEMS

Year	Part Number	Description	Boost Options	HP Gain	Intercooler	Price/MAP
1988-95 (5.7)	1GD212-SCI	High Output Intercooled System with P-1SC (5.7) - without air pump	8-9 psi	60-65%	2 core	\$6,448
1988-95 (5.7)	1GD202-SCI	High Output Intercooled Tuner Kit with P-1SC (5.7)	specify	specify	2 core	\$6,198
1988-95 (5.7)	1GD212-09I	High Output Intercooled System with P600B (5.7) - with air pump	8-9 psi	60-65%	2 core	\$6,148
1988-95 (7.4)	1GE212-SCI	High Output Intercooled System with P-1SC (7.4)	8-9 psi	60-65%	2 core	\$6,448
1988-95 (7.4)	1GE202-SCI	High Output Intercooled Tuner Kit with P-1SC (7.4)	specify	specify	2 core	\$6,198
1988-95 (7.4)	1GE212-09I	High Output Intercooled System with P600B (7.4)	8-9 psi	60-65%	2 core	\$6,148

2003-09 HUMMER H2 (6.0, 6.2) TUNER KITS

Year	Part Number	Description	Boost Options	HP Gain	Intercooler	Price/MAP
2008-09 (6.2)	1GL302-SCI	High Output Intercooled Tuner Kit with P-1SC-1 (6.2)	specify	specify	H2	\$7,148
2003-07 (6.0)	1GL202-SCI	High Output Intercooled Tuner Kit with P-1SC (6.0)	specify	specify	H2	\$6,998

Applications	Part Number Suffix	Description	Upgrade From	Requirements	Notes	Price/MAP
GM TRUCK	add "-B" to part #	Supercharger Finish: Black, max 9.75" housing	satn	max 9.75" housing	-	+\$295
	add "-P" to part #	Supercharger Finish: Polished, max 9.75" housing	satn	max 9.75" housing	-	+\$400
	add "-H" to part #	Gears: Helical gearset for noise reduction	straight-cut	P- or D-series only	-	+\$110
	add "-D1SC" to part #	Supercharger Upgrade: D-1SC	P-1SC	-	-	+\$525
	add "-D1" to part #	Supercharger Upgrade: D-1	P600B	1988-95 only	-	+\$750
HUMMER	add "-B" to part #	Supercharger Finish: Black, max 9.75" housing	satn	max 9.75" housing	-	+\$295
	add "-P" to part #	Supercharger Finish: Polished, max 9.75" housing	satn	max 9.75" housing	-	+\$400
	add "-BB" to part #	Supercharger Bracket Finish: Black	satn	-	-	+\$225
	add "-PB" to part #	Supercharger Bracket Finish: Polished	satn	-	-	+\$325
	add "-P1X" to part #	Supercharger Upgrade: P-1X	P-1SC	-	-	+\$500
	add "-P1X" to part #	Supercharger Upgrade: P-1X	P-1SC-1	-	add'l 10-15+ hp	+\$250
	add "-P1R" to part #	Supercharger Upgrade: P-1R	P-1SC	-	-	+\$800
	add "-P1R" to part #	Supercharger Upgrade: P-1R	P-1SC-1	Tuner Kits only	-	+\$600
	add "-D1SC" to part #	Supercharger Upgrade: D-1SC	P-1SC	-	-	+\$525
	add "-D1SC" to part #	Supercharger Upgrade: D-1SC	P-1SC-1	Tuner Kits only	-	+\$300
	add "-H" to part #	Gears: Helical gearset for noise reduction	straight-cut	P- or D-series only	-	+\$110
	add "-RVR" or "RVB"	Race Blow-off Valve Upgrade (specify open or closed, alum or steel, red or blk)	ProFlow	-	-	+\$295
	3GKMM-004	Crank Pin Kit	-	-	-	+\$109

SPECIFICATIONS

1996-00 GM TRUCK/SUV (5.7, 7.4) SPECIFICATIONS

Year	Part Number	OEM hp/TQ Rating	HP Gain	Tube Diam	IC Mount	Drive System	Blow-off System	Fuel System Upgrade	Fuel Inj. Supplied	Computer/Ignition Modifications	SC Warranty (in months)	CARB E.O.	Foot Notes
1996-00 (5.7)	1GH212-SCI	250/335	60-65%	3"	H	stk 6-rib	ProFlow	ProPump, FMU	not req'd	MAF massager	12, 36 opt. (\$99)	D-365-3	DD: 1, 2, 3, 4
1996-00 (5.7)	1GH202-SCI	250/335	specify	3"	H	stk 6-rib	ProFlow	not supplied	not req'd	not supplied	12	-	DD: 1, 2, 3, 4
1996-00 (7.4)	1GG202-SCI	290/410	specify	3"	H	stk 6-rib	ProFlow	not supplied	not req'd	not supplied	12	-	DD: 1, 2, 3, 4

1988-95 GM TBI TRUCK/SUV (5.7, 7.4) SPECIFICATIONS

Year	Part Number	OEM hp/TQ Rating	HP Gain	Tube Diam	IC Mount	Drive System	Blow-off System	Fuel System Upgrade	Fuel Inj. Supplied	Computer/Ignition Modifications	SC Warranty (in months)	CARB E.O.	Foot Notes
1988-95 (5.7)	1GD212-SCI	210/300	60-65%	3"	H	stk 6-rib	ProFlow	ProPump, FMU	not req'd	not required	12, 36 opt. (\$99)	D-365-3	DD: 1, 2, 3, 4, 5
1988-95 (5.7)	1GD202-SCI	210/300	specify	3"	H	stk 6-rib	ProFlow	not supplied	not req'd	not required	12	-	DD: 1, 2, 3, 4, 5
1988-95 (5.7)	1GD212-09I	210/300	60-65%	3"	H	stk 6-rib	ProFlow	ProPump, FMU	not req'd	not required	36	D-365-3	DD: 1, 2, 3, 4, 5
1988-95 (7.4)	1GE212-SCI	230/385	60-65%	3"	H	stk 6-rib	ProFlow	ProPump, FMU	not req'd	not required	12, 36 opt. (\$99)	D-365-3	DD: 1, 2, 3, 4
1988-95 (7.4)	1GE202-SCI	230/385	specify	3"	H	stk 6-rib	ProFlow	not supplied	not req'd	not required	12	-	DD: 1, 2, 3, 4
1988-95 (7.4)	1GE212-09I	230/385	60-65%	3"	H	stk 6-rib	ProFlow	ProPump, FMU	not req'd	not required	36	-	DD: 1, 2, 3, 4

2003-09 HUMMER H2 (6.0, 6.2) SPECIFICATIONS

Year	Part Number	OEM hp/TQ Rating	HP Gain	Tube Diam	IC Mount	Drive System	Blow-off System	Fuel System Upgrade	Fuel Inj. Supplied	Computer/Ignition Modifications	SC Warranty (in months)	CARB E.O.	Foot Notes
2008-09 (6.2)	1GL302-SCI	393/415	specify	2.5"	V	stk 6-rib	ProFlow	not supplied	No	not supplied	12	-	DD: 4, 6
2003-07 (6.0)	1GL202-SCI	316/360	specify	3"	H	stk 6-rib	ProFlow	none supplied	No	not supplied	12	-	DD: 4, 6

CHEVY TRUCK/SUV FOOTNOTES (specific to above applications):

- DD1) Model year must be specified
- DD2) Specify 2WD or 4WD, Truck or SUV
- DD3) Specify engine size
- DD4) Special order kit: order form and non-refundable deposit required at time of order—may require additional lead time for processing
- DD5) 88-95 with smog pump must use P600B
- DD6) Pinning the balancer to the crank is recommended; Pin kit for stock balancer not supplied



2019-24 RAM 1500 eTORQUE (5.7) / 2019-23 1500 (5.7) / 2011-2023 CLASSIC SYSTEMS AND KITS (SPECIFY IF REBEL OR GT)

Year	Part Number	Description	Boost Options	HP Gain	Intercooler	Price/MAP
2019-23	1DP314-SCI	High Output Intercooled System with D-1SC	7 psi	140+ hp	3 core	\$8,898
2019-23	1DP304-SCI	High Output Intercooled Tuner Kit with D-1SC	specify	specify	3 core	\$7,998
2019-23	1DP315-SCI	Stage II Intercooled System with P-1SC-1 (dedicated 8-rib drive)	7 psi	140+ hp	3 core	\$9,498
2019-23	1DP305-SCI	Stage II Intercooled Tuner Kit with P-1SC-1 (dedicated 8-rib drive)	specify	specify	3 core	\$8,598
2019-24	1DP415-SCI	Stage II Intercooled System with P-1SC-1 (eTorque)	7 psi	140+ hp	3 core	\$9,498
2019-24	1DP405-SCI	Stage II Intercooled Tuner Kit with P-1SC-1 (eTorque)	specify	specify	3 core	\$8,598
2011-23	1DH314-SCI	High Output Intercooled System with D-1SC (CLASSIC)	7 psi	140+ hp	3 core	\$8,898
2011-23	1DH304-SCI	High Output Intercooled Tuner Kit with D-1SC (CLASSIC)	specify	specify	3 core	\$7,998
2011-23	1DH315-SCI	Stage II Intercooled System with P-1SC-1 (dedicated 8-rib drive) (CLASSIC)	7 psi	140+ hp	3 core	\$9,498
2011-23	1DH305-SCI	Stage II Intercooled Tuner Kit with P-1SC-1 (dedicated 8-rib drive) (CLASSIC)	specify	specify	3 core	\$8,598

2014-25 RAM 2500/3500 AND POWER WAGON (6.4) SYSTEMS & KITS

Year	Part Number	Description	Boost Options	HP Gain	Intercooler	Price/MAP
2019-24	1DN312-SCI	High Output Intercooled Systems with D-1SC	6 psi	130+ hp	3 core	\$8,948
2019-25	1DN302-SCI	High Output Intercooled Tuner Kit with D-1SC	specify	specify	3 core	\$7,848
2014-18	1DN212-SCI	High Output Intercooled Systems with D-1SC	6 psi	130+ hp	3 core	\$8,848
2014-18	1DN202-SCI	High Output Intercooled Tuner Kit with D-1SC	specify	specify	3 core	\$7,748

2004-10 RAM (5.7) SYSTEMS AND KITS

Year	Part Number	Description	Boost Options	HP Gain	Intercooler	Price/MAP
2009-10	1DH214-SCI	High Output Intercooled System with P-1SC-1	7 psi	130+ hp	3 core	\$7,998
2009-10	1DH204-SCI	High Output Intercooled Tuner Kit with P-1SC-1	specify	specify	3 core	\$7,248
2009-10	1DH315-SCI	Stage II Intercooled System with P-1SC-1 (dedicated 8-rib drive)	7 psi	130+ hp	3 core	\$8,998
2009-10	1DH305-SCI	Stage II Intercooled Tuner Kit with P-1SC-1 (dedicated 8-rib drive)	specify	specify	3 core	\$8,348
2004-08	1DC214-SCI	High Output Intercooled System with P-1SC-1	6 psi	45-50%	3 core high mount	\$7,998
2004-08	1DC204-SCI	High Output Intercooled Tuner Kit with P-1SC-1	tuner kit only	specify	3 core high mount	\$7,148

1996-01 DODGE RAM (5.2, 5.9) TUNER KIT

Year	Part Number	Description	Boost Options	Est. hp Gain	Intercooler	Price/MAP
1996-01	1DA202-SCI	High Output Intercooled Tuner Kit with P-1SC	8-9 psi	55-60%	2 core	\$6,948

Applications	Part Number Suffix	Description	Upgrade From	Requirements	Notes	Price/MAP
ALL	add "B" to part #	Supercharger Finish: Black, max 9.75" housing	satin	max 9.75" housing	-	+\$295
	add "P" to part #	Supercharger Finish: Polished, max 9.75" housing	satin	max 9.75" housing	-	+\$400
	add "BB" to part #	Supercharger Bracket Finish: Black	satin	-	-	+\$225
	add "PB" to part #	Supercharger Bracket Finish: Polished	satin	-	-	+\$325
	add "H" to part #	Gears: Helical gearset for noise reduction	straight-cut	P- or D-series only	-	+\$110
2011-2024 1500 ONLY	add "P1X" to part #	Supercharger Upgrade: P-1X	P-1SC-1	Stage II only	add'l 10-15+ hp	+\$250
	add "P1R" to part #	Supercharger Upgrade: P-1R	P-1SC-1	Stage II Tuner Kit only	-	+\$600
	add "D1SC" to part #	Supercharger Upgrade: D-1SC	P-1SC-1	Stage II Tuner Kit only	-	+\$300
	add "D1X" to part #	Supercharger Upgrade: D-1X	P-1SC-1	Stage II Tuner Kit only	-	+\$500
	add "D" or "1" or "A"	Supercharger Upgrade: F-1D, F-1, F-1A	P-1SC-1	Stage II Tuner Kit only	-	+\$900
	add ".94" or ".C" or ".R"	Supercharger Upgrade: F-1A-94, F-1C or F-1R	P-1SC-1	Stage II Tuner Kit only	-	+\$1,250
	add ".103" to part #	Supercharger Upgrade: F-1R-103	P-1SC-1	Stage II Tuner Kit only	-	+\$2,300
	add "D1X" to part #	Supercharger Upgrade: D-1X	D-1SC	Tuner Kits only	-	+\$200
	add "A"	Supercharger Upgrade: F-1A	D-1SC	Tuner Kits only	-	+\$575
	add "RVR" or "RVB"	Race Blow-off Valve Upgrade (specify open or closed, alum or steel, red or blk)	ProFlow	Stage II only	-	+\$295
add "ATIPP" to part #	ATI Performance Products Balancer Upgrade	-	Stage II, non-eTorque only	-	+\$550	
POWER WGN	add "PW" to part #	Power Wagon w/ Factory Winch (included in 2019+)	-	2014-18 only	-	+\$175
2004-10 ONLY	add "D1SC" to part #	Supercharger Upgrade: D-1SC	P-1SC-1	Tuner Kits only	-	+\$300
	add "LM" to part #	Intercooler Upgrade: Low mount	high mount	2006-08 only	-	+\$110
1996-01 ONLY	add "D1SC" to part #	Supercharger Upgrade: D-1SC	P-1SC	-	-	+\$525
	add ".3C" to part #	Intercooler Upgrade: 3 core air-to-air, 825 hp max	2 core	-	3" tubing	+\$550

SPECIFICATIONS

2019-24 RAM 1500 eTORQUE (5.7) / 2019-23 1500 (5.7) / 2011-2023 CLASSIC SPECIFICATIONS (SPECIFY IF REBEL OR GT)

Year	Part Number	OEM hp/TQ Rating	HP Gain	Tube Diam	IC Mount	Drive System	Blow-off System	Fuel System Upgrade	Fuel Inj. Supplied	Computer/Ignition Modifications	SC Warranty (in months)	CARB E.O.	Foot Notes
2019-23	1DP314-SCI	390/407	140+ hp	3"	V	stk 6-rib	ProFlow	not required	39.5 lb/hr	programmer sup.	12, 36 opt. (\$99)	-	GG: 1, 2, 3, 4, 6
2019-23	1DP304-SCI	390/407	specify	3"	V	stk 6-rib	ProFlow	-	No	not supplied	12	-	GG: 1, 2, 4, 5
2019-23	1DP315-SCI	390/407	140+ hp	3"	V	add'l 8-rib	ProFlow	not required	39.5 lb/hr	programmer sup.	12, 36 opt. (\$99)	-	GG: 1, 2, 3, 4, 6, 7
2019-23	1DP305-SCI	390/407	specify	3"	V	add'l 8-rib	ProFlow	-	No	not supplied	12	-	GG: 1, 2, 4, 7
2019-24	1DP415-SCI	390/407	140+ hp	3"	V	add'l 8-rib	ProFlow	not required	39.5 lb/hr	programmer sup.	12, 36 opt. (\$99)	-	GG: 1, 2, 3, 4, 6
2019-24	1DP405-SCI	390/407	specify	3"	V	add'l 8-rib	ProFlow	-	No	not supplied	12	-	GG: 1, 2, 4, 5
2011-23	1DH314-SCI	390/407	140+ hp	3"	V	stk 6-rib	ProFlow	not required	39.5 lb/hr	programmer sup.	12, 36 opt. (\$99)	-	GG: 1, 2, 3, 4, 6
2011-23	1DH304-SCI	390/407	specify	3"	V	stk 6-rib	ProFlow	-	No	not supplied	12	-	GG: 1, 2, 4, 5
2011-23	1DH315-SCI	390/407	140+ hp	3"	V	add'l 8-rib	ProFlow	not required	39.5 lb/hr	programmer sup.	12, 36 opt. (\$99)	D-365-9 (09-14) D-365-18 (15-18)	GG: 1, 2, 4, 6, 7
2011-23	1DH305-SCI	390/407	specify	3"	V	add'l 8-rib	ProFlow	-	No	not supplied	12	-	GG: 1, 2, 4, 7

2014-25 RAM 2500/3500 AND POWER WAGON (6.4) SPECIFICATIONS

Year	Part Number	OEM hp/TQ Rating	HP Gain	Tube Diam	IC Mount	Drive System	Blow-off System	Fuel System Upgrade	Fuel Inj. Supplied	Computer/Ignition Modifications	SC Warranty (in months)	CARB E.O.	Foot Notes
2019-24	1DN312-SCI	410/429	130+ hp	3"	V	stk 6-rib	Bullet	not required	52 lb/hr	programmer sup.	12, 36 opt. (\$99)	-	GG: 1, 2, 3, 6
2019-25	1DN302-SCI	410/429	specify	3"	V	stk 6-rib	Bullet	-	No	not supplied	12	-	GG: 1, 2
2014-18	1DN212-SCI	410/429	130+ hp	3"	V	stk 6-rib	ProFlow	not required	52 lb/hr	programmer sup.	12, 36 opt. (\$99)	-	GG: 1, 2, 3, 6
2014-18	1DN202-SCI	410/429	specify	3"	V	stk 6-rib	ProFlow	-	No	not supplied	12	-	GG: 1, 2

2004-10 DODGE RAM (5.7) SPECIFICATIONS

Year	Part Number	OEM hp/TQ Rating	HP Gain	Tube Diam	IC Mount	Drive System	Blow-off System	Fuel System Upgrade	Fuel Inj. Supplied	Computer/Ignition Modifications	Supercharger Warranty (in months)	CARB E.O.	Foot Notes
2009-10	1DH214-SCI	390/407	130+ hp	3"	V	stk 6-rib	ProFlow	not required	39.5 lb/hr	programmer sup.	12, 36 opt. (\$99)	D-365-9	GG: 1, 4, 7
2009-10	1DH204-SCI	390/407	specify	3"	V	stk 6-rib	ProFlow	-	No	not supplied	12	-	GG: 1, 4, 7
2009-10	1DH315-SCI	390/407	130+ hp	3"	V	add'l 8-rib	ProFlow	not required	39.5 lb/hr	programmer sup.	12, 36 opt. (\$99)	D-365-9	GG: 1, 4, 7
2009-10	1DH305-SCI	390/407	specify	3"	V	add'l 8-rib	ProFlow	-	No	not supplied	12	-	GG: 1, 4, 7
2004-08	1DC214-SCI	345/375	45-50%	3"	V	stk 7 rib	ProFlow	not required	39.5 lb/hr	programmer sup.	12, 36 opt. (\$99)	D-365-7	GG: 1, 2, 4, 8, 9
2004-08	1DC204-SCI	345/375	specify	3"	V	stk 7 rib	ProFlow	not supplied	No	not supplied	12	-	GG: 1, 2, 4, 8, 9

1996-01 DODGE RAM (5.9, 5.2) SPECIFICATIONS

Year	Part Number	OEM hp/TQ Rating	Est. hp Gain	Tube Diam	IC Mount	Drive System	Blow-off System	Fuel System Upgrade	Fuel Inj. Supplied	Computer/Ignition Modifications	Supercharger Warranty (in months)	CARB E.O.	Foot Notes
1996-01	1DA202-SCI	250/335	55-60%	3"	H	stk 7 rib	ProFlow	not supplied	not required	not required	12	-	GG: 1, 2, 4, 9

DODGE TRUCK/SUV FOOTNOTES (specific to above applications):

- GG1) Model year must be specified
- GG2) Specify 2WD or 4WD
- GG3) Due to variability among OEM computers, the prevalence of custom modifications, and age/miles/condition of vehicles, dyno tuning may be required
- GG4) For 1500 Series only; modification and custom tuning required for 2500 Series vehicles and above (2500, 3500, Mega Cab, and Power Wagon) - Tuner Kits only
- GG5) 2013+ models require aerodynamic-shutter removal
- GG6) 2015+ vehicles require ECM unlock (call for details) - not included
- GG7) Requires ATI Performance Products balancer #918453 (not included - specify hardened hub)
- GG8) Low mount intercooler option available for 2006-08 model years only
- GG9) Special order kit: order form and non-refundable deposit required at time of order—may require additional lead time for processing



2018-24 DODGE DURANGO SRT (6.4) SYSTEMS & KITS

Year	Part Number	Description	Boost Options	HP Gain	Intercooler	Price/MAP
2018-24	1DL215-SCI	High Output Intercooled System with P-1SC-1	7 psi	215+ hp	3 core	\$8,698
2018-24	1DL205-SCI	High Output Intercooled Tuner Kit with P-1SC-1	specify	specify	3 core	\$7,798

2018-25 DODGE DURANGO (5.7L) SYSTEMS & KITS

Year	Part Number	Description	Boost Options	HP Gain	Intercooler	Price/MAP
2018-25	1DM215-SCI	High Output Intercooled System with P-1SC-1	7 psi	160+ hp	3 core	\$8,698
2018-25	1DM205-SCI	High Output Intercooled Tuner Kit with P-1SC-1	specify	specify	3 core	\$7,798

1997-01 DODGE DAKOTA/DURANGO (5.2, 5.9) TUNER KIT

Year	Part Number	Description	Boost Options	Est. hp Gain	Intercooler	Price/MAP
1997-01	1DB202-SCI	High Output Intercooled Tuner Kit with P-1SC	8-9 psi	55-60%	2 core	\$6,898

OPTIONS FOR THIS PAGE	Applications	Part Number Suffix	Description	Upgrade From	Requirements	Notes	Price/MAP	
	ALL		add "-B" to part #	Supercharger Finish: Black, max 9.75" housing	satin	max 9.75" housing	-	+\$295
			add "-P" to part #	Supercharger Finish: Polished, max 9.75" housing	satin	max 9.75" housing	-	+\$400
			add "-BB" to part #	Supercharger Bracket Finish: Black	satin	-	-	+\$225
			add "-PB" to part #	Supercharger Bracket Finish: Polished	satin	-	-	+\$325
			add "-H" to part #	Gears: Helical gearset for noise reduction	straight-cut	P- or D-series only	-	+\$110
			add "-P1X" to part #	Supercharger Upgrade: P-1X	P-1SC-1	2018-25 only	add'l 10-15+ hp	+\$250
			add "-P1R" to part #	Supercharger Upgrade: P-1R	P-1SC-1	2018-25 Tuner Kits	-	+\$600
			add "-D1SC" to part #	Supercharger Upgrade: D-1SC	P-1SC-1	2018-25 Tuner Kits	-	+\$300
			add "-D1X" to part #	Supercharger Upgrade: D-1X	P-1SC-1	2018-25 Tuner Kits	-	+\$500
			add "-D" or "-1" or "-A"	Supercharger Upgrade: F-1D, F-1, F-1A	P-1SC-1	2018-25 Tuner Kits	-	+\$900
		add "-94" to part #	Supercharger Upgrade: F-1A-94	P-1SC-1	2018-25 Tuner Kits	-	+\$1,250	
	add "-RVR" or "RVB"	Race Blow-off Valve Upgrade (specify open or closed, alum or steel, red or blk)	ProFlow	-	-	+\$295		
	add "-D1SC" to part #	Supercharger Upgrade: D-1SC	P-1SC	1994-01 only	-	+\$525		

SPECIFICATIONS

2018-24 DODGE DURANGO SRT (6.4) SPECIFICATIONS

Year	Part Number	OEM hp/TQ Rating	HP Gain	Tube Diam	IC Mount	Drive System	Blow-off System	Fuel System Upgrade	Fuel Inj. Supplied	Comp./Ignition Modifications	SC Warranty (in months)	CARB E.O.	Foot Notes
2018-24	1DL215-SCI	475/470	215+ hp	3"	V	stk 6-rib	ProFlow	MAP sensor	52 lb/hr	programmer sup.	12, 36 opt. (\$99)	D-365-35 (18-22)	HH: 1, 3
2018-24	1DL205-SCI	475/470	specify	3"	V	stk 6-rib	ProFlow	not supplied	No	not supplied	12	-	HH: 1

2018-25 DODGE DURANGO (5.7L) SPECIFICATIONS

Year	Part Number	OEM hp/TQ Rating	HP Gain	Tube Diam	IC Mount	Drive System	Blow-off System	Fuel System Upgrade	Fuel Inj. Supplied	Comp./Ignition Modifications	SC Warranty (in months)	CARB E.O.	Foot Notes
2018-25	1DM215-SCI	360	160+ hp	3"	V	stk 6-rib	ProFlow	MAP sensor	52 lb/hr	programmer sup.	12, 36 opt. (\$99)	D-365-35 (18-22)	HH: 1, 3
2018-25	1DM205-SCI	360	specify	3"	V	stk 6-rib	ProFlow	not supplied	No	not supplied	12	-	HH: 1

1997-01 DODGE DAKOTA/DURANGO (5.9, 5.2) SPECIFICATIONS

Year	Part Number	OEM hp/TQ Rating	Est. hp Gain	Tube Diam	IC Mount	Drive System	Blow-off System	Fuel System Upgrade	Fuel Inj. Supplied	Computer/Ignition Modifications	Supercharger Warranty (in months)	CARB E.O.	Foot Notes
1997-01	1DB202-SCI	250/335	55-60%	3"	H	stk 7 rib	ProFlow	not supplied	not required	not required	12	-	HH: 1, 2, 6, 7

DODGE TRUCK/SUV FOOTNOTES (specific to above applications):

- HH1) Model year must be specified
- HH2) Specify 2WD or 4WD
- HH3) 2015+ vehicles require ECM unlock (call for details) - not included
- HH5) MSD boost timing master may be required (sold separately by others)
- HH6) For 1500 Series only; modification and custom tuning required for 2500 Series vehicles and above (2500, 3500, Mega Cab, and Power Wagon) (Tuner Kits only)
- HH7) Special order kit: order form and non-refundable deposit required at time of order—may require additional lead time for processing



2012-21 JEEP GRAND CHEROKEE (6.4) SYSTEMS & KITS

Year	Part Number	Description	Boost Options	HP Gain	Intercooler	Price/MAP
2012-20	1DL214-SCI	High Output Intercooled System with P-1SC-1	7 psi	215+	3 core	\$8,698
2012-21	1DL204-SCI	High Output Intercooled Tuner Kit with P-1SC-1	specify	specify	3 core	\$7,798

2011-21 JEEP GRAND CHEROKEE (5.7) SYSTEMS AND KITS

Year	Part Number	Description	Boost Options	HP Gain	Intercooler	Price/MAP
2011-21	1DM214-SCI	High Output Intercooled System with P-1SC-1	7 psi	160+	3 core	\$8,698
2011-21	1DM204-SCI	High Output Intercooled Tuner Kit with P-1SC-1	specify	specify	3 core	\$7,798

2006-10 JEEP GRAND CHEROKEE SRT8 (6.1) SYSTEMS AND KITS

Year	Part Number	Description	Boost Options	HP Gain	Intercooler	Price/MAP
2006-10	1DJ214-SCI	High Output Intercooled System with P-1SC-1	7 psi	160+	3 core	\$8,298
2006-10	1DJ204-SCI	High Output Intercooled Tuner Kit with P-1SC-1	specify	specify	3 core	\$6,998
2006-10	1DJ314-SCI	Stage II Intercooled System with P-1SC-1 (dedicated 8-rib)	7 psi	160+	3 core	\$8,798
2006-10	1DJ304-SCI	Stage II Intercooled Tuner Kit with P-1SC-1 (dedicated 8-rib)	specify	specify	3 core	\$7,448

2020-25 JEEP GLADIATOR JT (3.6) SYSTEMS AND KITS

Year	Part Number	Description	Boost Options	HP Gain	Intercooler	Price/MAP
2020-25	1JT214-SCI	High Output Intercooled System with P-1SC-1	7 psi	40-45%+	custom JL	\$7,698
2020-25	1JT204-SCI	High Output Intercooled Tuner Kit with P-1SC-1	specify	specify	custom JL	\$6,748

2018-25 JEEP WRANGLER JL (3.6) SYSTEMS AND KITS (NON-ETORQUE)

Year	Part Number	Description	Boost Options	HP Gain	Intercooler	Price/MAP
2018-25	1JL214-SCI	High Output Intercooled System with P-1SC-1	7 psi	40-45%+	custom JL	\$7,698
2018-25	1JL204-SCI	High Output Intercooled Tuner Kit with P-1SC-1	specify	specify	custom JL	\$6,748

2012-18 JEEP WRANGLER JK (3.6) SYSTEMS AND KITS

Year	Part Number	Description	Boost Options	HP Gain	Intercooler	Price/MAP
2012-18	1JK214-SCI	High Output Intercooled System with P-1SC-1	7 psi	50%+	custom JK	\$7,598
2012-18	1JK204-SCI	High Output Intercooled Tuner Kit with P-1SC-1	specify	specify	custom JK	\$6,648

OPTIONS FOR THIS PAGE	Applications	Part Number Suffix	Description	Upgrade From	Requirements	Notes	Price/MAP	
	ALL	add "-B" to part #		Supercharger Finish: Black, max 9.75" housing	satn	max 9.75" housing	-	+\$295
		add "-P" to part #		Supercharger Finish: Polished, max 9.75" housing	satn	max 9.75" housing	-	+\$400
		add "-BB" to part #		Supercharger Bracket Finish: Black	satn	-	-	+\$225
		add "-PB" to part #		Supercharger Bracket Finish: Polished	satn	-	-	+\$325
		add "-H" to part #		Gears: Helical gearset for noise reduction	straight-cut	P- or D-series only	-	+\$110
		add "-D1SC" to part #		Supercharger Upgrade: D-1SC	P-1SC-1	Tuner Kits only	-	+\$300
	GRAND CHEROKEE ONLY	add "-P1X" to part #		Supercharger Upgrade: P-1X	P-1SC-1	-	add'l 10-15+ hp	+\$250
		add "-P1R" to part #		Supercharger Upgrade: P-1R	P-1SC-1	Tuner Kits only	-	+\$600
		add "-D1X" to part #		Supercharger Upgrade: D-1X	P-1SC-1	Tuner Kits only	-	+\$500
add "-D" or "-1" or "-A"			Supercharger Upgrade: F-1D, F-1, F-1A	P-1SC-1	Tuner Kits only	-	+\$900	
add "-94" to part #			Supercharger Upgrade: F-1A-94	P-1SC-1	Tuner Kits only	-	+\$1,250	
add "-RVR" or "RVB"			Race Blow-off Valve Upgrade (specify open or closed, alum or steel, red or blk)	ProFlow	-	-	+\$295	
JK, JL ONLY	add "-Race" to part #		Intercooler Upgrade: Race air-to-air, 1100 HP max	3-core	-	-	+\$435	
	add "-BI" to part #		Intercooler Finish: Black	raw	-	-	+\$195	

CALL FOR MORE INFO ON NEWER MODEL YEARS

SPECIFICATIONS

2012-21 JEEP GRAND CHEROKEE (6.4) SPECIFICATIONS

Year	Part Number	OEM hp/TQ Rating	HP Gain	Tube Diam	IC Mount	Drive System	Blow-off System	Fuel System Upgrade	Fuel Inj. Supplied	Comp./Ignition Modifications	SC Warranty (in months)	CARB E.O.	Foot Notes
2012-20	1DL214-SCI	475/470	215+ hp	3"	V	stk 6-rib	ProFlow	MAP sensor	52 lb/hr	programmer sup.	12, 36 opt. (\$99)	D-365-26 (12-20)	JJ: 1, 6, 8
2012-21	1DL204-SCI	475/470	specify	3"	V	stk 6-rib	ProFlow	not supplied	No	not supplied	12	-	JJ: 1, 8

2011-21 JEEP GRAND CHEROKEE (5.7) SPECIFICATIONS

Year	Part Number	OEM hp/TQ Rating	HP Gain	Tube Diam	IC Mount	Drive System	Blow-off System	Fuel System Upgrade	Fuel Inj. Supplied	Comp./Ignition Modifications	SC Warranty (in months)	CARB E.O.	Foot Notes
2011-21	1DM214-SCI	360/390	160+ hp	3"	V	stk 6-rib	ProFlow	MAP sensor	39.5 lb/hr	programmer sup.	12, 36 opt. (\$99)	D-365-22 (11-19)	JJ: 1, 6, 8
2011-21	1DM204-SCI	360/390	specify	3"	V	stk 6-rib	ProFlow	not supplied	No	not supplied	12	-	JJ: 1, 8

2006-10 JEEP GRAND CHEROKEE SRT8 (6.1) SPECIFICATIONS

Year	Part Number	OEM hp/TQ Rating	HP Gain	Tube Diam	IC Mount	Drive System	Blow-off System	Fuel System Upgrade	Fuel Inj. Supplied	Comp./Ignition Modifications	SC Warranty (in months)	CARB E.O.	Foot Notes
2006-10	1DJ214-SCI	425/425	160+ hp	3"	V	stk 6-rib	ProFlow	MAP sensor, pump voltage booster	52 lb/hr	programmer sup.	12, 36 opt. (\$99)	D-365-9	JJ: 1
2006-10	1DJ204-SCI	425/425	specify	3"	V	stk 6-rib	ProFlow	not supplied	No	not supplied	12	-	JJ: 1
2006-10	1DJ314-SCI	425/425	160+ hp	3"	V	add'l 8-rib	ProFlow	MAP sensor, pump voltage booster	52 lb/hr	programmer sup.	12, 36 opt. (\$99)	D-365-9	JJ: 1, 7
2006-10	1DJ304-SCI	425/425	specify	3"	V	add'l 8-rib	ProFlow	not supplied	No	not supplied	12	-	JJ: 1, 7

2020-25 JEEP GLADIATOR JT (3.6) SPECIFICATIONS

Year	Part Number	OEM hp/TQ Rating	HP Gain	Tube Diam	IC Mount	Drive System	Blow-off System	Fuel System Upgrade	Fuel Inj. Supplied	Comp./Ignition Modifications	SC Warranty (in months)	CARB E.O.	Foot Notes
2020-25	1JT214-SCI	285/260	40-45%+	2.5-3"	V	stk 6-rib	ProFlow	not required	50 lb/hr	programmer sup.	12, 36 opt. (\$99)	D-365-36 (20-23 only)	JJ: 1, 2, 3, 6, 9, 10
2020-25	1JT204-SCI	285/260	specify	2.5-3"	V	stk 6-rib	ProFlow	not supplied	No	not supplied	12	-	JJ: 1, 2, 3, 5

2018-25 JEEP WRANGLER JL (3.6) SPECIFICATIONS (NON-ETORQUE)

Year	Part Number	OEM hp/TQ Rating	HP Gain	Tube Diam	IC Mount	Drive System	Blow-off System	Fuel System Upgrade	Fuel Inj. Supplied	Comp./Ignition Modifications	SC Warranty (in months)	CARB E.O.	Foot Notes
2018-25	1JL214-SCI	285/260	40-45%+	2.5-3"	V	stk 6-rib	ProFlow	not required	50 lb/hr	programmer sup.	12, 36 opt. (\$99)	D-365-36 (18-23 only)	JJ: 1, 2, 3, 6, 9, 10
2018-25	1JL204-SCI	285/260	specify	2.5-3"	V	stk 6-rib	ProFlow	not supplied	No	not supplied	12	-	JJ: 1, 2, 3, 5

2012-18 JEEP WRANGLER JK (3.6) SPECIFICATIONS

Year	Part Number	OEM hp/TQ Rating	HP Gain	Tube Diam	IC Mount	Drive System	Blow-off System	Fuel System Upgrade	Fuel Inj. Supplied	Comp./Ignition Modifications	SC Warranty (in months)	CARB E.O.	Foot Notes
2012-18	1JK214-SCI	285/260	50%+	2.5-3"	V	stk 6-rib	ProFlow	not required	50 lb/hr	programmer sup.	12, 36 opt. (\$99)	D-365-36	JJ: 1, 2, 3, 6
2012-18	1JK204-SCI	285/260	specify	2.5-3"	V	stk 6-rib	ProFlow	not supplied	No	not supplied	12	-	JJ: 1, 2, 3, 5

JEEP WRANGLER, GLADIATOR, & GRAND CHEROKEE FOOTNOTES (specific to above applications):

- I1) Model year must be specified
- I2) Specify 2WD or 4WD
- I3) Specify manual or automatic transmission
- I5) May not work with some aftermarket parts or accessories
- I6) 2015+ vehicles require PCM unlock
- I7) Requires ATI Performance Products balancer #918432 (not included - specify hardened hub)
- I8) Some trimming required to airbox tabs
- I9) Specify if PCM is GPEC2A or GPEC5 for 2021+ model year vehicles
- I10) CARB E.O. for GPEC2 only



2010-24 TOYOTA 4RUNNER (4.0) SYSTEMS & KITS

Year	Part Number	Description	Boost Options	HP Gain	Intercooler	Price/MAP
2010-24	1TK212-SCI	High Output Intercooled System with D-1SC	7-8 psi	40-45%	3 core	\$7,598
2010-24	1TK202-SCI	High Output Intercooled Tuner Kit with D-1SC	specify	specify	3 core	\$6,598

2016-23 TOYOTA TACOMA (3.5) SYSTEMS & KITS

Year	Part Number	Description	Boost Options	HP Gain	Intercooler	Price/MAP
2016-23	1TM212-SCI	High Output Intercooled System with D-1SC	7-8 psi	40-45%	3 core	\$7,498
2016-23	1TM202-SCI	High Output Intercooled Tuner Kit with D-1SC	specify	specify	3 core	\$6,598

2005-15 TOYOTA TACOMA (4.0) SYSTEMS & KITS

Year	Part Number	Description	Boost Options	HP Gain	Intercooler	Price/MAP
2005-15	1TL212-SCI	High Output Intercooled System with D-1SC	7-8 psi	40-45%	3 core	\$7,248
2005-15	1TL202-SCI	High Output Intercooled Tuner Kit with D-1SC	specify	specify	3 core	\$5,998

OPTIONS THIS PAGE	Applications	Part Number Suffix	Description	Upgrade From	Requirements	Notes	Price/MAP	
	FINISH OPTIONS		add "B" to part #	Supercharger Finish: Black, max 9.75" housing	satin	max 9.75" housing	-	+\$295
			add "P" to part #	Supercharger Finish: Polished, max 9.75" housing	satin	max 9.75" housing	-	+\$400
			add "BB" to part #	Supercharger Bracket Finish: Black	satin	-	-	+\$225
			add "PB" to part #	Supercharger Bracket Finish: Polished	satin	-	-	+\$325
			add "BI" to part #	Intercooler Finish: Black	raw	-	-	+\$195
	KIT UPGRADES		add "BC"	Black finish for optional intake manifold cover	raw	4Runner only	-	+\$35
			add "H" to part #	Gears: Helical gearset for noise reduction	straight-cut	P- or D-series only	-	+\$110
			add "IU" to part #	Air-to-Air intercooler option for aftermarket bumper and/or winch	std 3-core	-	-	n/c
			add "MC"	Optional ProCharger intake manifold cover, satin finish	raw	4Runner only	-	+\$145
		add "IU" to part #	Air-to-Air intercooler option for aftermarket bumper and/or winch	std 3-core	2005-10 MY only	-	n/c	

SPECIFICATIONS

2010-24 TOYOTA 4RUNNER (4.0) SPECIFICATIONS

Year	Part Number	OEM hp/TQ Rating	HP Gain	Tube Diam	IC Mount	Drive System	Blow-off System	Fuel System Upgrade	Fuel Inj. Supplied	Comp./Ignition Modifications	SC Warranty (in months)	CARB E.O.	Foot Notes
2010-24	1TK212-SCI	270/278	40-45%+	3"	V	add'l 6-rib	ProFlow	-	60 lb/hr	programmer sup.	12, 36 opt. (\$99)	D-365-39	TT: 1, 2, 3, 5, 7, 8, 10
2010-24	1TK202-SCI	270/278	specify	3"	V	add'l 6-rib	ProFlow	not supplied	No	not supplied	12	-	TT: 1, 2, 3, 5, 7, 8

2016-23 TOYOTA TACOMA (3.5) SPECIFICATIONS

Year	Part Number	OEM hp/TQ Rating	HP Gain	Tube Diam	IC Mount	Drive System	Blow-off System	Fuel System Upgrade	Fuel Inj. Supplied	Comp./Ignition Modifications	SC Warranty (in months)	CARB E.O.	Foot Notes
2016-23	1TM212-SCI	278/265	40-45%	3"	V	stk 6-rib	ProFlow	pump voltage booster	-	programmer sup.	12, 36 opt. (\$99)	D-365-39	TT: 1, 2, 3, 5, 6, 7, 8, 9, 10
2016-23	1TM202-SCI	278/265	specify	3"	V	stk 6-rib	ProFlow	not supplied	No	not supplied	12	-	TT: 1, 2, 3, 5, 6, 7, 8, 9

2005-15 TOYOTA TACOMA (4.0) SPECIFICATIONS

Year	Part Number	OEM hp/TQ Rating	HP Gain	Tube Diam	IC Mount	Drive System	Blow-off System	Fuel System Upgrade	Fuel Inj. Supplied	Comp./Ignition Modifications	SC Warranty (in months)	CARB E.O.	Foot Notes
2005-15	1TL212-SCI	236/266	40-45%	3"	V	add'l 6-rib	ProFlow	pump voltage booster	52 lb/hr	programmer sup.	12, 36 opt. (\$99)	D-365-39 (2005-13)	TT: 1, 2, 3, 5, 6, 7
2005-15	1TL202-SCI	236/266	specify	3"	V	add'l 6-rib	ProFlow	not supplied	No	not supplied	12	-	TT: 1, 2, 3, 5, 6, 7

TOYOTA 4RUNNER, TACOMA, TUNDRA FOOTNOTES (specific to above applications):

- TT1) Model year must be specified
- TT2) Specify 2WD or 4WD or AWD
- TT3) Specify manual or automatic transmission
- TT5) May not work with some aftermarket parts or accessories
- TT6) Radiator support modification required
- TT7) Specify with or without winch/snorkel option
- TT8) Battery relocation required (single battery bracket supplied)
- TT9) Specify passenger or driver side ABS
- TT10) VF Tuner requires Windows computer



POWERSPORTS

2015-19 POLARIS SLINGSHOT

Year	Part Number	Description	Boost Options	HP Gain	Intercooler	Price/MAP
2015-19	1PD112-SCI	High Output Intercooled System with CS-1	8 psi	55%+	3 core	\$5,999
2015-19	1PD102-SCI	High Output Intercooled Tuner Kit with CS-1	specify	specify	3 core	\$5,799

SPORT COMPACT

2003-06 NISSAN 350Z (3.5) TUNER KITS (DOES NOT FIT 2006 REV-UP ENGINE MODEL)

Year	Part Number	Description	Boost Options	Est. hp Gain	Intercooler	Price/MAP
2003-06	1NB202-SCI	High Output Intercooled Tuner Kit with C-2	7 psi	55-60%	350Z	\$6,699

2003-04 INFINITI G35 COUPE AND FX35 (3.5) TUNER KITS

Year	Part Number	Description	Boost Options	Est. hp Gain	Intercooler	Price/MAP
2003-04	1NC202-SCI	High Output Intercooled Tuner Kit with C-2	6 psi	45-50%	G35	\$6,699

1999-00 HONDA CIVIC Si (1.6 DOHC) TUNER KITS

Year	Part Number	Description	Boost Options	Est. hp Gain	Intercooler	Price/MAP
1999-00	1HA202-SCI	High Output Intercooled Tuner Kit with C-1A	9 psi	70-75%	2 core	\$5,999

1994-01 ACURA INTEGRA GSR AND TYPE R (1.8 DOHC) TUNER KITS

Year	Part Number	Description	Boost Options	Est. hp Gain	Intercooler	Price/MAP
1994-01	1HB202-SCI	High Output Intercooled Tuner Kit with C-1A	8 psi	70-75%	2 core	\$5,999

2000-04 FORD FOCUS (ZETEC, SVT) TUNER KITS

Year	Part Number	Description	Boost Options	Est. hp Gain	Intercooler	Price/MAP
2000-03	1FK202-SCI	High Output Intercooled Tuner Kit with C-1B (Zetec)	8, 10 psi	65-80%	Focus	\$5,599
2002-04	1FK302-SCI	High Output Intercooled Tuner Kit with C-1B (SVT)	8, 10 psi	65-80%	Focus	\$5,599

OPTIONS	Applications	Part Number Suffix	Description	Upgrade From	Requirements	Notes	Price/MAP
	ALL	add "B" to part #	Supercharger Finish: Black, 7" housing	satin	7" housing	-	+\$295
		add "P" to part #	Supercharger Finish: Polished, 7" housing	satin	7" housing	-	+\$400
		add "BB" to part #	Supercharger Bracket Finish: Black	satin	-	-	+\$225
		add "PB" to part #	Supercharger Bracket Finish: Polished	satin	-	-	+\$325
		add "3C" to part #	Intercooler Upgrade: 3-core air-to-air	2-core	Honda only	-	+\$435

LOOKING FOR V-TWIN OR POWERSPORTS SUPERCHARGERS? GIVE US A CALL OR VISIT PROCHARGE

i-1 OPTIONS

A handful of applications have an i-1 supercharger system product option. See the individual applications for this list.

OPTIONS	Applications	Part Number Suffix	Description	Upgrade From	Requirements	Notes	Price/MAP
	i-1 ONLY	add "B" to part #	Black finish (supercharger and bracket)	-	-	-	+\$795
		add "P" to part #	Polished finish (supercharger and bracket)	-	-	-	+\$595
		add "ATIPP" to part #	ATI Performance Products Balancer Upgrade	-	Camaro SS only	-	+\$550
		add "R" to part #	Air-to-air race intercooler upgrade	-	excl. Camaro SS	-	+\$435

SPECIFICATIONS

2015-19 POLARIS SLINGSHOT SPECIFICATIONS

Year	Part Number	OEM hp Rating	HP Gain	Tube Diam	Intercooler Mount	Drive System	Blow-off System	Fuel System Upgrade	Fuel Inj. Supplied	Computer/Ignition Modifications	Supercharger Warranty (in months)	CARB E.O.	Foot Notes
2015-19	1PD112-SCI	173	55%+	2.5"	V	stk 6-rib	ProFlow Bullet	not required	not req.	tuning certificate	12	-	SC: 6
2015-19	1PD102-SCI	173	specify	2.5"	V	stk 6-rib	ProFlow Bullet	not required	No	No	12	-	SC: 6

2003-06 NISSAN 350Z (3.5) SPECIFICATIONS

Year	Part Number	OEM hp Rating	Est. hp Gain	Tube Diam	Intercooler Mount	Drive System	Blow-off System	Fuel System Upgrade	Fuel Inj. Supplied	Computer/Ignition Modifications	Supercharger Warranty (in months)	CARB E.O.	Foot Notes
2003-06	1NB202-SCI	287	55-60%	2.5"	V	stk 6-rib	ProFlow	not supplied	No	not supplied	12	-	SC: 1, 3, 6

2003-04 INFINITI G35 COUPE, FX35 (3.5) SPECIFICATIONS

Year	Part Number	OEM hp Rating	Est. hp Gain	Tube Diam	Intercooler Mount	Drive System	Blow-off System	Fuel System Upgrade	Fuel Inj. Supplied	Computer/Ignition Modifications	Supercharger Warranty (in months)	CARB E.O.	Foot Notes
2003-04	1NC202-SCI	280	45-50%	2.5"	V	stk 6-rib	ProFlow	not supplied	No	not supplied	12	-	SC: 1, 6

1999-00 HONDA CIVIC Si (1.6L DOHC) SPECIFICATIONS

Year	Part Number	OEM hp Rating	Est. hp Gain	Tube Diam	Intercooler Mount	Drive System	Blow-off System	Fuel System Upgrade	Fuel Inj. Supplied	Computer/Ignition Modifications	Supercharger Warranty (in months)	CARB E.O.	Foot Notes
1999-00	1HA202-SCI	160	70-75%	2.5"	V	stk 4 rib	Bosch	not supplied	No	not supplied	12	-	SC: 1, 6

1994-01 ACURA INTEGRA GSR, TYPE R (1.8L DOHC) SPECIFICATIONS

Year	Part Number	OEM hp Rating	Est. hp Gain	Tube Diam	Intercooler Mount	Drive System	Blow-off System	Fuel System Upgrade	Fuel Inj. Supplied	Computer/Ignition Modifications	Supercharger Warranty (in months)	CARB E.O.	Foot Notes
1994-01	1HB202-SCI	170	70-75%	2.5"	V	stk 4 rib	Bosch	not supplied	No	not supplied	12	-	SC: 1, 2, 4, 6

2000-04 FORD FOCUS (ZETEC, SVT) SPECIFICATIONS

Year	Part Number	OEM hp Rating	Est. hp Gain	Tube Diam	Intercooler Mount	Drive System	Blow-off System	Fuel System Upgrade	Fuel Inj. Supplied	Computer/Ignition Modifications	Supercharger Warranty (in months)	CARB E.O.	Foot Notes
2000-03	1FK202-SCI	130	65-80%	2.5"	H	stk 6-rib	Bosch	not required	No	not supplied	12	-	SC: 1, 6
2002-04	1FK302-SCI	170	65-80%	2.5"	H	stk 6-rib	Bosch	not required	No	not supplied	12	-	SC: 1, 6

SPORT COMPACT FOOTNOTES (specific to above applications):

JJ1) Model year must be specified

JJ2) Specify GS-R or Type R

JJ3) For Non Rev-up engines only

JJ4) Acura Integra systems and kits require modifications to bumper support

JJ5) Boost levels are for reference only—tuning and fuel system upgrades may be required (sold by others)

JJ6) Special order kit: order form and non-refundable deposit required at time of order—may require additional lead time for processing



	A-1R	B-1	CS-1	C-1	C-2	P600B	P-1SC	P-1SC-1	P-1X	P-1R	D-1	D-1SC	D-1X	F-1D	F-1	F-1A	F-1A-91	F-1A-94
VOLUTE DIAMETER	7"	7"	7"	7"	7"	9"	9"	9"	9"	9"	9"	9"	9"	9"	9"	9"	9"	9"
MAX SUPERCHARGED HP	150	250	550	675	725	775	825	825	950	1250	925	925	1075	1050	1050	1100	1200	1300
MOTOR BASE HP RANGE*	50-95	60-150	150-325	150-325	175-375	200-500	200-500	200-450	300-500	300-500	300-500	300-500	300-550	300-500	300-500	300-500	300-500	300-550
MAX FLOW (CFM)	450	600	900	1,000	1,000	1,150	1,200	1,200	1,275	1,600	1,400	1,400	1,500	1,500	1,525	1,575	1,600	1,625
MAX BOOST (PSI)	15	20	24	24	24	24	30	32	32	36	32	32	32	34	38	38	38	38
INLET HOSE DIAMETER	3"	3"	3.5"	3.5"	3.5"	3.75"	3.75"	3.75"	3.75"	3.75"	3.75"	3.75"	3.75"	3.75"	3.75"	3.75"	3.75"	4"
INDUCER DIAMETER	2.28"	2.28"	2.66"	2.75"	3.14"	3.37"	3.37"	3.37"	3.57"	3.75"	3.37"	3.37"	3.57"	3.37"	3.57"	3.5"	3.57"	3.7"
EXDUCER DIAMETER	3.2"	3.2"	3.7"	4.25"	4.25"	6.25"	6.25"	5.25"	5.56"	5.56"	6.25"	6.25"	6.20"	6.25"	6"	5.56"	5.56"	5.56"
OUTLET HOSE DIAMETER	2"	2"	2.5"	2.5"	2.5"	3"	3"	3"	3"	3"	3"	3"	3"	3"	3"	3"	3"	3"
OUTLET I.D.	1.75"	1.75"	2.12"	2.12"	2.12"	2.62"	2.62"	2.62"	2.62"	2.62"	2.62"	2.62"	2.62"	2.62"	2.62"	2.62"	2.62"	2.62"
MAX IMPELLER RPM	75,000	110,000	80,000	80,000	80,000	60,000	62,000	65,000	65,000	65,000	65,000	62,000	65,000	65,000	70,000	74,000	74,000	74,000
INTERNAL STEP-UP	4.11:1	4.95:1	8.30:1	4.70:1	4.70:1	3.05:1	4.10:1	4.10:1	4.10:1	4.10:1	4.44:1	4.10:1	4.10:1	5.40:1	5.40:1	5.40:1	5.40:1	5.40:1
REVERSE ROTATION OPTION	Yes	Yes	Yes	Yes	Yes	Yes	Yes	Yes	Yes	Yes	Yes	Yes	Yes	Yes	Yes	Yes	Yes	Yes
SELF CONTAINED	Yes	Yes	Yes	Yes	Yes	No	Yes	Yes	Yes	Yes	No	Yes	Yes	Yes	Yes	Yes	Yes	Yes
OIL CAPACITY	2.5 oz	2.5 oz	3.2 oz	2.5 oz	2.5 oz	-	6 oz	6 oz	6 oz	6 oz	-	6 oz	6 oz	4 oz	4 oz	4 oz	4 oz	4 oz

- The stated figures are not absolutes, and may actually be higher depending upon the specific application.
- Figures based on stated peak airflows; actual power levels may be higher in well prepared engines.
- Please refer to www.procharger.com for additional supercharger specifications.

- Engine intake air temperature is the most relevant thermal measure (not SAE J1723) for a supercharger installed on a vehicle, especially when intercooled; SAE J1723 does not address the impact of engine dynamics, engine compartment heat transfer, intercooling or deficiencies caused by supercharger location.

	F-1C	F-1R	F-1R-103	F-1X	F-2	F-3D-102	F-3D-106	F-3R-102	F-3R-112	F-3R-121	F-3R-130	F-3R-136	F-4R-136	F-4X-136	F-4X-140	F-4X-140-1	F-4X-146
VOLUTE DIAMETER	9.75"	9.75"	9.75"	10.5"	10.5"	10.5"	10.5"	12"	12"	12"	12"	12"	12"	13.5"	14.5"	14.5"	14.5"
MAX SUPERCHARGED HP	1,100	1,250	1,500	1,400	1,450	1,500	1,800	1,600	2,100	2,400	2,700	3,000	3,000	3,200	3,700	4,000	4,500
MOTOR BASE HP RANGE	300-550	375-550	450-650	375-550	425-600	550-750	550-750	375-550	CALL	CALL	CALL	CALL	CALL	CALL	CALL	CALL	CALL
MAX FLOW (CFM)	1,625	1,700	1,900	2,000	2,100	1,900	2,200	2,000	2,300	3,100	3,600	4,000	4,000	4,200	4,500	4,700	5,200
MAX BOOST (PSI)	38	38	38	38	38	38	38	38	38	40	45	50	50	55	60	65	72
INLET HOSE DIAMETER	4"	4.05"	4.05"	4.8"	4.6"	4.8"	4.8"	6"	5"	5.5"	5.75"	5.75"	5.75"	6"	6"	6"	6"
INDUCER DIAMETER	3.7"	4"	4.25"	4.20"	4.5"	4"	4.2"	4"	4.4"	4.8"	5.12"	5.23"	5.23"	5.35"	5.37"	5.55"	5.75"
EXDUCER DIAMETER	5.56"	6"	6"	6"	6.75"	6"	6"	6.75"	6.75"	6.75"	7.22"	7.22"	7.22"	7.22"	7.22"	7.22"	7.92"
OUTLET HOSE DIAMETER	3"	3"	3.5"	3.5"	3.5"	3.5"	3.5"	4.5"	4"	4"	4"	4"	4"	4.5"	5"	5"	5"
OUTLET I.D.	2.62"	2.62"	3.15"	3.15"	3.15"	3.15"	3.15"	3.59"	3.59"	3.59"	3.59"	3.59"	3.59"	4"	5"	5"	5"
MAX IMPELLER RPM	74,000	68,000	72,000	72,000	65,000	74,000	74,000	72,000	72,000	72,000	72,000	72,000	72,000	72,000	72,000	72,000	72,000
INTERNAL STEP-UP	5.40:1	5.40:1	5.40:1	5.40:1	5.40:1	5.63:1	5.63:1	5.63:1	5.63:1	5.63:1	5.63:1	5.63:1	4.77:1	4.77:1	4.77:1	4.77:1	4.77:1
REVERSE ROTATION OPTION	Yes	Yes	Yes	Yes	Yes	No	Yes	No	Yes	Yes	Yes	Yes	No	No	No	No	No
SELF CONTAINED	Yes	Yes	Yes	Yes	Yes	Yes	Yes	Yes	Yes	Yes	Yes	Yes	Yes	Yes	Yes	Yes	Yes
OIL CAPACITY	4 oz	4 oz	4 oz	4 oz	4 oz	6 oz Race Oil	6 oz Race Oil	6 oz Race Oil	6 oz Race Oil	6 oz Race Oil	6 oz Race Oil	6 oz Race Oil	6 oz Race Oil	6 oz Race Oil	6 oz Race Oil	6 oz Race Oil	6 oz Race Oil

- F-1/F-2 superchargers are rated based upon high horsepower street engines. F-3 superchargers are rated based upon maximum effort race engines.

- The stated figures are not absolutes, and may actually be higher depending upon the specific application.
- Please refer to www.procharger.com for additional supercharger specifications.

- Figures based on stated peak airflows; actual power levels may be higher in well prepared engines.

- Engine intake air temperature is the most relevant thermal measure (not SAE J1723) for a supercharger installed on a vehicle, especially when intercooled; SAE J1723 does not address the impact of engine dynamics, engine compartment heat transfer, intercooling or deficiencies caused by supercharger location.

SUPERCHARGERS

Part Number	Description	Price/MAP
PC065A-xxx	A-1R ProCharger (satin)	\$2,798
PC064A-xxx	B-1 ProCharger (satin)	\$2,798
PC061A-xxx	C-1 ProCharger (satin)	\$3,098
PC061A-xxx	C-1R ProCharger (satin)	\$3,548
PC061A-xxx	C-1R-72 ProCharger (satin)	\$3,748
PC062A-xxx	C-2 ProCharger (satin)	\$3,548
PC061A-xxx	CS-1 ProCharger (satin)	\$3,648
PC061A-xxx	C-1X ProCharger (satin)	\$3,648
PC010A-xxx	P600B ProCharger (satin)	\$3,248
PC050A-xxx	P-1SC ProCharger (satin)	\$3,598
PC050A-xxx	P-1SC-1 ProCharger (satin)	\$3,798
PC053A-xxx	P-1X ProCharger (satin)	\$4,098
PC055A-xxx	P-1R ProCharger (satin)	\$4,398
PC041A-xxx	D-1 ProCharger (satin)	\$3,998
PC051A-xxx	D-1SC ProCharger (satin)	\$4,148
PC054A-xxx	D-1X ProCharger (satin)	\$4,298
PC323A-xxx	F-1D ProCharger (satin)	\$4,698
PC324A-xxx	F-1 ProCharger (satin)	\$4,698
PC325A-xxx	F-1A ProCharger (satin)	\$4,698
PC335A-xxx	F-1A-91 ProCharger (satin)	\$5,048
PC336A-xxx	F-1A-94 ProCharger (satin)	\$5,048
PC327A-xxx	F-1C ProCharger (satin)	\$5,048
PC326A-xxx	F-1R ProCharger (satin)	\$5,048
PC338A-xxx	F-1R-103 ProCharger (satin)	\$6,098
PC330A-xxx	F-1X ProCharger (satin)	\$6,298
PC328A-xxx	F-2 ProCharger (satin)	\$6,498
PC314A-102	F-3D-102 ProCharger (satin)	\$7,498
PC314A-106	F-3D-106 ProCharger (satin)	\$7,498
PC314A-102R	F-3R-102 ProCharger (satin) with splined input shaft and threaded volute	\$8,698
PC314A-112R	F-3R-112 (F-1X-12) ProCharger (satin)	\$7,998
PC314A-121R	F-3R-121 ProCharger (satin)	\$8,298
PC314A-130	F-3R-130 ProCharger (satin)	\$8,498
PC314A-136	F-3R-136 ProCharger (satin)	\$8,898
PC314A-140-C-SP-T	F-4R-136 ProCharger (satin) with splined input shaft and threaded volute	\$11,098
PC318A-136-C-SP-T	F-4X-136 ProCharger (satin) with splined input shaft and threaded volute	\$11,398
PC318A-140-C-SP-T	F-4X-140 ProCharger (satin) with splined input shaft and threaded volute	\$16,498
PC318A-141-C-SP-T	F-4X-140-1 ProCharger (satin) with splined input shaft and threaded volute	\$16,998
PC318A-145-C-SP-T	F-4X-146 ProCharger (satin) with splined input shaft and threaded volute	\$19,498
CALL	F-3R Threaded Volute w/ V-Band Clamp (new head unit builds)	\$299
CALL	F-3R Threaded Volute w/ Dual Seal Flange (new head unit builds)	\$299
CALL	F-3D/F-3R Splined Input Shaft Option (new head unit builds)	\$199
add "B" to part #	Supercharger Finish: Black, max 9.75" housing	+\$295
add "P" to part #	Supercharger Finish: Polished, max 9.75" housing	+\$400
add "B" to part #	Supercharger Finish: Black, 10.5" housing	+\$395
add "P" to part #	Supercharger Finish: Polished, 10.5" housing	+\$500
add "B" to part #	Supercharger Finish: Black, 12" housing	+\$650
add "P" to part #	Supercharger Finish: Polished, 12" housing	+\$750

ACCESSORIES, PARTS, AND MORE

WATER PUMPS

Part #	Description	Price/MAP
GA1001-006	SBC Water Pump (satin finish)	\$153
GA1001-006B	SBC Water Pump (black finish)	\$165
GA1001-006P	SBC Water Pump (polished finish)	\$208
GA1001-007	BBC Water Pump (satin finish)	\$153
GA1001-007B	BBC Water Pump (black finish)	\$165
GA1001-007P	BBC Water Pump (polished finish)	\$208
GA1001-004	LS Water Pump (satin finish)	\$205
GA1001-004B	LS Water Pump (black finish)	\$255
GA1001-004P	LS Water Pump (polished finish)	\$284
GA1001-009	SBF Water Pump 86-93 (satin finish)	\$153
GA1001-009B	SBF Water Pump 86-93 (black finish)	\$165
GA1001-009P	SBF Water Pump 86-93 (polished finish)	\$208

POWER STEERING PUMPS, A/C COMPRESSORS

Part #	Description	Price/MAP
GA1001-002	P/S Pump GM Type 2, satin finish	\$160
GA1001-002B	P/S Pump GM Type 2, black finish	\$242
GA1001-002P	P/SPump GM Type 2, polished finish	\$242
GA1001-001	A/C Sanden SD-7B10, satin finish	\$260
GA1001-001B	A/C Sanden SD-7B10, black finish	\$260
GA1001-001P	A/C Sanden SD-7B10, polished finish	\$502

ALTERNATORS

Part #	Description	Price/MAP
GA1001-005	Alternator - CS130 160AMP (satin finish)	\$295
GA1001-005B	Alternator - CS130 160AMP (black finish)	\$365
GA1001-005P	Alternator - CS130 160AMP (polished finish)	\$365
3LSAL-001	LS/LT Alt w/ wire 225 AMP (satin finish)	\$499
3LSAL-001B	LS/LT Alt w/ wire 225AMP (black finish)	\$499
3LSAL-001P	LS/LT Alt w/ wire 225 AMP (polished finish)	\$509
GA1001-008	SBF Alt 150AMP 3G (satin finish)	\$385
GA1001-008B	SBF Alt 150 AMP 3G (black finish)	\$390
GA1001-008P	SBF Alt 150 AMP 3G (polished finish)	\$515

MORE PROCHARGER PARTS & RACING COMPONENTS



Shop **PROCHARGER.COM** or request a ProCharger **Parts & Racing Guide** catalog, free of charge.



CATALOGS: DIGITAL & PRINT

ProCharger's industry leading catalogs are available for download at **ProCharger.com**, or request a printed version free of charge.



MERCH

Race over to our online store and show your ProCharger pride with a great selection of ProCharger merch!



AIR-TO-AIR INTERCOOLERS

Part #	Max HP	End Tank Type	In/Out Location	In/Out DIA.	Core Width	Height	Depth	Price/MAP
AI002A-001	500	Sheet Metal	Opposite Sides	3"	18	12.5	3	\$898
AIFP1A-001	650	Sheet Metal	Opposite Sides	3"	24	12.5	3.5	\$1,198
AI003A-001	825	Sheet Metal	Opposite Sides	3"	27	12.5	3	\$1,198
AI003A-002	950	Sheet Metal	Opposite Sides	3"	27	15	3	\$1,398
AIDD1A-071	1000	Sheet Metal	Opposite Sides	3"	24	20	3	\$1,498
AI003A-005	1050	Sheet Metal	Opposite Sides	3.5"	27	15	3	\$1,498
AI045A-001	1300	Sheet Metal	Opposite Sides	3.5"	27	12	4.5	\$1,798
AI006A-001	1550	Sheet Metal	Opposite Sides	4"	27	12	6	\$2,298
AIJK1A-002	425	Sheet Metal	Opposite Sides Cross Flow	3"	18	11	3	\$1,198
AIFR1A-010	650	Sheet Metal	Opposite Sides Cross Flow	3"	29	12	3.5	\$1,198
AIGN2A-011	800	Sheet Metal	Opposite Sides Cross Flow	3"	29	12	4.5	\$1,398
AIFW1A-035	1200	Sheet Metal	Opposite Sides Cross Flow	3.5"	20	17.5	4.5	\$1,498
AIGU1A-001	1000	Sheet Metal	Front, Cross Flow	3"	34	9	4.5	\$1,398
AIDD1A-015	750	Sheet Metal	Top/Side	3"	24	17	3	\$1,198
AIGO3A-001	1050	Sheet Metal	Top/Side	3"	27	13	3.5	\$1,398
AIGO3A-003	1300	Sheet Metal	Top/Side	3.5"	27	12	4.5	\$1,498
AIGO3A-004	1300	Sheet Metal	Top/Side	3.5"/4"	27	12	4.5	\$1,598
AI002A-003	500	Sheet Metal	Same Side	3"	18	12.5	3	\$998
AIGN1A-001	600	Sheet Metal	Same Side	3"	18	12.5	3.5	\$998
AI003A-003	825	Sheet Metal	Same Side	3"	27	12.5	3	\$998
AI003A-004	950	Sheet Metal	Same Side	3"	27	15	3	\$1,398
AIDG1A-073	1000	Sheet Metal	Same Side	3"	24	20	3	\$1,498
AI003A-006	1050	Sheet Metal	Same Side	3.5"	27	15	3	\$1,398
AI045A-002	1300	Sheet Metal	Same Side	3.5"	27	15	4.5	\$2,198
AI006A-002	1550	Sheet Metal	Same Side	4"	27	12	6	\$2,398

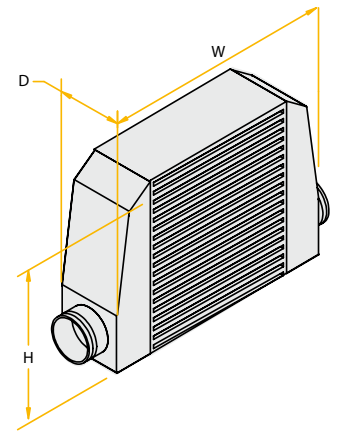

AIR-TO-AIR TWIN INTERCOOLERS

Part #	Max HP	End Tank Type	In/Out Location	In/Out DIA.	Core Width	Height	Depth	Price/MAP
AIGB1A-XXX	500 Per Pair	Twin Sheet Metal	Opposite Sides	2"	9	10.5	3	\$798
AIGA1A-XXX	750 Per Pair	Twin Sheet Metal	Opposite Sides	2.5"	9	11	3.5	\$798
AIGK1A-XXX	850 Per Pair	Twin Sheet Metal	Front/Side	3"	9	11	4.5	\$898

AIR-TO-WATER RACE INTERCOOLERS (ICE WATER)

Part #	Max HP	End Tank Type	In/Out Location	In/Out DIA.	Core Width	Height	Depth	Price/MAP
AIGU1I-123	1500	Sheet Metal/Billet	Same Side	3.5"	12.5	10	12	\$1,698
WI1005A-003	1500	Sheet Metal	Same Side	3.5"	13	11	9	\$1,898
WI1005A-001	1800	Sheet Metal	Same Side	4"	9	13	19	\$2,498
WI1005A-002	2400	Sheet Metal	Same Side	4"	13	13	23	\$2,998

NEW AIR-TO-WATER INTERCOOLED INTAKE MANIFOLDS - SEE NEXT PAGE

Visit **PROCHARGER.COM** for more details and specifications on ProCharger's full range of intake manifolds.



Options	Part Number Suffix	Description	Upgrade	Req'ts	Notes	Price/MAP
	add "-BI" to part #	A/A Intercooler Finish: Black	raw	-	-	+\$175
	add "-BIW" to part #	A/W Intercooler Finish: Black	raw	-	-	+\$275
	add "-WP" to part #	Universal Water Pump	-	-	-	call
	add "-3C" to part #	Universal Heat Exchanger	-	-	-	call

NEW AIR-TO-WATER INTERCOOLED INTAKE MANIFOLDS

Part #	ENGINE	Max HP	End Tank Type	In/Out Location	In/Out DIA.	Height	Cylinder Heads	Fuel Injectors	Throttle Body	Price/MAP
AI040A-080	LS Engine	1250	Billet	Front	-12 ORB	9"	LS3-style square port	EV14, compact with ext. tip	Up to 92mm	\$4,999
AI040A-063	LT Engine	1250	Billet	Front	-12 ORB	9.6"	LT1/LT2/LT4	-	Up to 92mm	\$4,999
AI040A-060	LT Engine with port injection	1250	Billet	Front	-12 ORB	9.6"	LT1/LT2/LT4	EV14, standard	Up to 92mm	\$5,499
Call	Gen 3 HEMI Engine	TBD	TBD	TBD	TBD	TBD			TBD	call
Call	Coyote Engine	TBD	TBD	TBD	TBD	TBD			TBD	call
Call	BBC Engine	TBD	TBD	TBD	TBD	TBD			TBD	call

OTHER INTAKE MANIFOLDS

Part #	Description	Upgrade From	Requirements	Notes	Price/MAP
2GUSU-001	Sheet Metal Aluminum Intake Manifold and Cover	OEM manifold	LT1/LT4 only		+\$2,498
2GUSU-001-INJ	Sheet Metal Aluminum Intake Manifold and Cover w/ injector bungs and fuel rails	OEM manifold	LT1/LT4 only		+\$2,998

Options	Part Number Suffix	Description	Upgrade From	Requirements	Notes	Price/MAP
	add "-SL" to part #	Intercooled Intake Solid Lid (no logo or design elements)	-	-	-	no charge
	add "-B" to part #	Intercooled Intake Lid Finish: Black	raw	logo lid only	-	+\$350
	add "-P" to part #	Intercooled Intake Lid Finish: Polished	raw	logo lid only	-	+\$500
	add "-BB" to part #	Intercooled Intake Lid Finish: Black Contrast Cut	raw	logo lid only	-	+\$450
	add "-PB" to part #	Intercooled Intake Base Finish: Black	raw	-	-	+\$275
	Call	Universal Water Pump	-	-	-	call
	Call	Universal Heat Exchanger	-	-	-	call
	add "-BIC" to part #	LT1/LT4 Intake Manifold Finish: Black	raw	non-intercooled only	-	+\$225
	add "-BC" to part #	LT1/LT4 Intake Manifold Cover Finish: Black	raw	non-intercooled only	-	+\$35

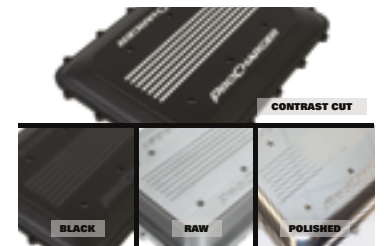

CARB HATS

Part #	Description	Upgrade From	Notes	Price/MAP
AM006A-001	Low Profile Carb Hat 4150, satin finish	-	3" inlet, 2" height	+\$180
AM001A-001	Competition Carb Hat 4150, satin finish	-	3.5" inlet, 4.5" height	+\$292
AM009A-001	Standard Carb Hat 4150, satin finish	-	3.5" inlet, 2.75" height	+\$242
AM001A-002B	Competition Carb Hat 4500, black finish	-	5" inlet, 5.5" height	+\$508
AM001A-002P	Competition Carb Hat 4500, polished finish	-	5" inlet, 5.5" height	+\$468
add "-CB" to part #	Carb Hat Upgrade: Competition 4150 (at time of purchase)	standard	3.5" inlet, 4.5" height	+\$50
add "-CB" to part #	Carb Hat Upgrade: Competition 4150 (at time of purchase)	low profile	3.5" inlet, 4.5" height	+\$72
add "-DCP" to part #	Carb Hat Upgrade: Competition 4500, polished finish (at time of purchase)	standard	5" inlet, 5.5" height	+\$150
add "-DCB" to part #	Carb Hat Upgrade: Competition 4500, black finish (at time of purchase)	standard	5" inlet, 5.5" height	+\$266
add "-BB" to part #	Carb Hat Finish: Black	satin	-	+\$100
add "-PB" to part #	Carb Hat Finish: Polished	satin	-	+\$100

PROCHARGER[®]
INVENTED, ENGINEERED AND MADE IN THE USA



**THE WORLD'S
MOST POWERFUL
SUPERCHARGERS**

FOLLOW US



#PROCHARGER

Headquarters Campus Kansas City



San Francisco Office



CALL OR EMAIL

Sales/Service Phone Hours: 8:00 am – 5:30 pm CST (M-F)
Sales Email Address: sales@procharger.com
Technical Service Email: ts@procharger.com
Customer Service Email: cs@procharger.com



14801 W. 114TH TERR LENEXA, KS 66215 • PH: (913) 338-2886 • WWW.PROCHARGER.COM

